



XT Series Electrode Steam Humidifiers

- *Interoperable with building automation systems*
- *Web-enabled remote diagnostics and control*
- *Data logging and firmware updates via USB*



New design!

XT Series humidifier components

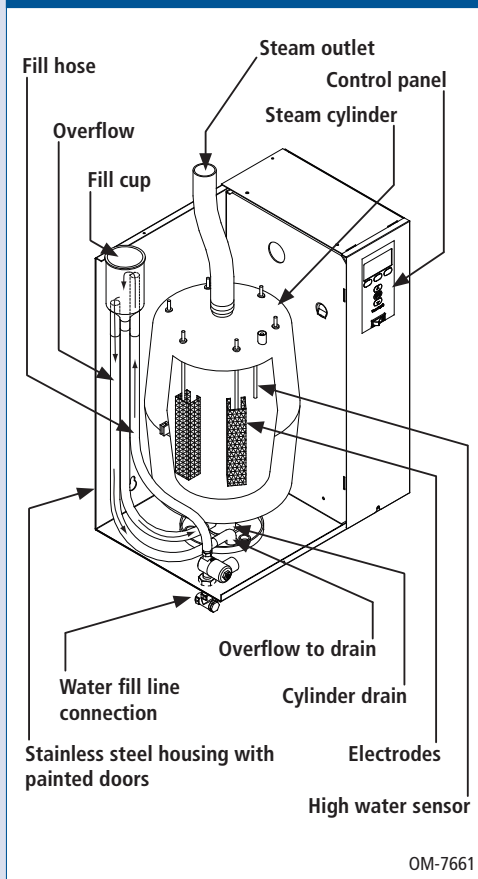

DRI-STEEM XT Series electrode steam humidifiers provide humidification for a wide range of buildings, including health care, commercial, industrial, and government facilities. Easy installation and minimal maintenance make XT Series one of the most convenient options in humidification.

Easy to maintain

Easy to replace the steam cylinder when prompted. The stainless steel housing and painted doors resist corrosion.

Adaptable

- Compact in size to fit into small spaces, with attractive cabinet for finished-space applications
- Capacity range from 2 to 113 kg/h; stage up to four humidifiers together for maximum system capacity of 454 kg/h
- Disperses steam into ductwork or open spaces
- Works with water conductivity from 125 to 1250 $\mu\text{S}/\text{cm}$
- User-selectable drain water tempering, if desired

Comprehensive control with Vapor-logic®4

- Easy-to-use menus for all humidifier functions, with Web interface for access to all functions via Ethernet
- Accurate, responsive RH control with PID tuning for maximum performance
- Modbus® and optional BACnet® or LonTalk® provide interoperability with building automation systems
- USB port allows firmware updates and data backup and restore
- Data logging allows controller data to be downloaded to a PC for viewing and analysis
- Automatic draining and filling optimize humidifier performance according to your specific water type



Vapor-logic4 controller keypad/display



Easy to maintain. Just replace the affordable steam cylinder when prompted.

Insert a USB flash drive into the Vapor-logic4 board's USB port to perform firmware updates, or to back up and restore data.

- *Ideal for finished-space and limited-space applications.*
- *Electrical connections are easily accessible.*
- *Plumbing connections are included for hassle-free installation.*

XT Series humidifier technical data

Model	Input power (kW)	Nominal steam capacity (kg/h)	Nominal current draw (amps)*			Shipping weight (kg)	Maximum operating weight (kg)	Dimensions (mm)		
			Single-phase		Three-phase			Width	Height	Depth
			230V	400V						
XTP002	1.7	2	7	—	—	17	17	370	522	221
XTP003	3.3	5	15	8	5	17	17	370	522	221
XTP006	6.0	8	26	15	9	17	21	370	522	221
XTP010	10.0	14	—	—	14	22	35	451	560	300
XTP017	16.5	22	—	—	23	22	35	451	560	300
XTP025	25.0	34	—	—	36	28	50	504	598	340
XTP033	33.3	45	—	—	48	28	50	504	598	340
XTP042	41.7	57	—	—	60	28	50	504	598	340
XTP050	50.0	68	—	—	2 x 36	61	97	1005	598	340
XTP067	66.7	91	—	—	2 x 48	61	97	1005	598	340
XTP083	83.3	113	—	—	2 x 60	61	97	1005	598	340

XT steam blower technical data

Model	Input power (Watts)	Maximum capacity (kg/h)	Current draw at 115V, 50/60 Hz	Shipping weight (kg)	Operating weight (kg)	Dimensions (mm)		
						Width	Height	Depth
SDU-006E2	17	9.1	0.16 A	5.7	4.3	373	152	198
SDU-017E2	23	22.7	0.23 A	12.5	11.3	455	350	279

Expect quality from the industry leader

For more than 45 years, DRI-STEEM has been leading the industry with creative and reliable humidification solutions. Our focus on quality is evident in the construction of our XT Series humidifiers. DRI-STEEM leads the industry with a Two-year Limited Warranty and optional extended warranty.

For more information

www.dristeem.com
sales@dristeem.com

For the most recent product information visit our website:

www.dristeem.com

DRI-STEEM Corporation

An ISO 9001:2000 certified company

European office:

Marc Briers
Grote Hellekensstraat 54 b
B-3520 Zonhoven
Belgium

+3211823595 (voice)

+3211817948 (fax)

E-mail: marc.briers@dristeem.com

U.S. Headquarters:

14949 Technology Drive
Eden Prairie, MN 55344
800-328-4447 or 952-949-2415
952-229-3200 (fax)

Continuous product improvement is a policy of DRI-STEEM Corporation; therefore, product features and specifications are subject to change without notice.

DRI-STEEM and Vapor-logic are registered trademarks of DRI-STEEM Corporation and are filed for trademark registration in Canada and the European community.

Product and corporate names used in this document may be trademarks or registered trademarks. They are used for explanation only without intent to infringe.

© 2011 DRI-STEEM Corporation



Form No. XT-Brochure-1011

Steam dispersion options

Dispersion tubes and panels for ducts

Single or multiple tubes

- Horizontal or vertical airflow
- Steam capacity up to 39 kg/h



Rapid-sorb®

- Single-header design
- Short non-wetting distance
- Steam capacity up to 363 kg/h



Ultra-sorb® Model LV

- Shortest non-wetting distance
- Factory assembled for easy installation
- Steam capacity up to 839 kg/h



High-Efficiency Tube option

- Up to 85% reduction in wasted energy, airstream heat gain, and condensate production
- PVDF insulation is plenum-approved for in-duct installation
- Available on Ultra-sorb and Rapid-sorb



XT steam blowers for open spaces

- Suitable for finished spaces and rooms with no air-handling ducts
- Mount on top of XT Series humidifier, or mount multiple steam blowers remotely on wall
- Steam capacity up to 22.7 kg/h

Your DRI-STEEM Distributor is: