

**DRISTEEM**<sup>®</sup>  
The humidification experts



## Vaporstream<sup>®</sup>

Electric-to-Steam  
Humidification System

PRODUCT CATALOG



Now with Vapor-logic<sup>®</sup>4 controller:

- Web-enabled access
- Interoperability via Modbus<sup>®</sup> or optional BACnet<sup>®</sup> or LonTalk<sup>®</sup>

# High-performance humidification



*DRI-STEEM® offers a complete line of Vaporstream models to meet a wide range of humidification needs.*

## Application versatility

From providing comfort humidity to meeting the strictest clean-room requirements, the Vaporstream electric humidifier is an industrial-grade unit designed to meet the humidification demands of any building environment. Vaporstream models and options include multiple control capabilities, a broad capacity range, and compatibility with all water types.

## Precise control with Vapor-logic4

Vaporstream with Vapor-logic4 sets new standards for control in electric steam humidification:

**Interoperability** allows communication with building automation systems via Modbus or with optional BACnet or LonTalk protocols.

**Safety presets** initiate fill and drain cycles and keep the humidifier cool and safe if sensed conditions, though unlikely, could be hazardous.

**Web-enabled control** allows you to set up, view, and adjust humidifier functions via Ethernet, either directly or remotely through a network.



**DRI-STEEM** Vapor-logic4

STATUS ALARMS DIAGNOSTICS SETUP HELP

System Status **Wednesday, January 27, 2010 3:42:28 PM** Data stream is LIVE

View all humidifier settings below. Some settings can be changed here. Go to the Setup tab to change settings that cannot be changed from this page.

DEMAND	OUTPUT
0%	0%

RUN MODE Local standby

TANK STATUS	Empty
-------------	-------

Alarms  
2 active alarms  
> View Alarms

Messages  
2 active messages  
> View Messages

**TANK STATUS:**

Run Mode	Local standby	CHANGE
Input signal	18.2 VDC	
Steam output	0%	
Steam production	0 lbs/hr	
Duct HL switch	Closed	
Tank temperature	192°F	
Tank temp signal	1623 Ohms	
High water probe	Water	
Mid water probe	Water	
Low water probe	Water	
Fill valve	Open	
Drain valve	Open	
Airflow switch	Flow	
Interlock switch	Closed	
H2O until drain/flush	123456 lbs	
H2O until service	30000 lbs	
High probe signal	3874	
Mid probe signal	3875	
Low probe signal	3873	

© Copyright 2009 DRI-STEEM Corporation. All rights reserved. Vapor-logic4 is a registered trademark of DRI-STEEM Corporation.

## Vaporstream features and benefits

### Proven performance

- Consistent and reliable RH control to  $\pm 1\%$
- On-off or time-proportioned (TP) control for application control in most environments; solid-state relay (SSR) option for tighter control
- Electronically monitored water level ensures safe and reliable operation

### Application flexibility

- Uses tap, softened, or DI/RO water
- Broad capacity range from 5.7 to 285 lbs/hr (2.6 to 129 kg/h), link up to 16 units for capacity up to 4560 lbs/hr (2068 kg/h)
- Dispersion options from an Area-type fan in open space to dispersion panels in ducts and air handlers meet a wide range of absorption requirements
- Designed to work with any voltage with a wide range of heater sizes, staging options, and model configurations
- Weather cover and climate-controlled outdoor enclosure options

### Easy maintenance

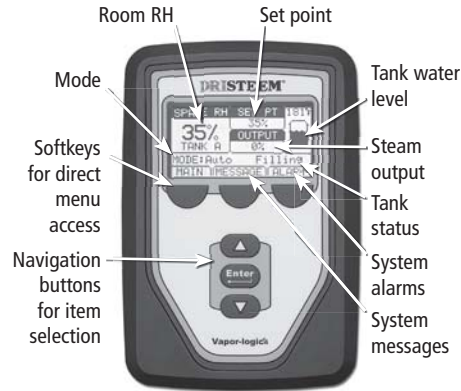
- Cleanout plate and removable cover provide inspection and service access
- Softened water significantly reduces maintenance requirements
- End-of-season autodrain minimizes microbial growth
- User-adjustable water skimmer skims off floating minerals
- Controller-operated drain and flush removes precipitated minerals from evaporating chamber
- Constant thermal expansion and contraction of heating elements continuously sheds mineral buildup
- Easy access to water level control — no components to remove

### Additional options

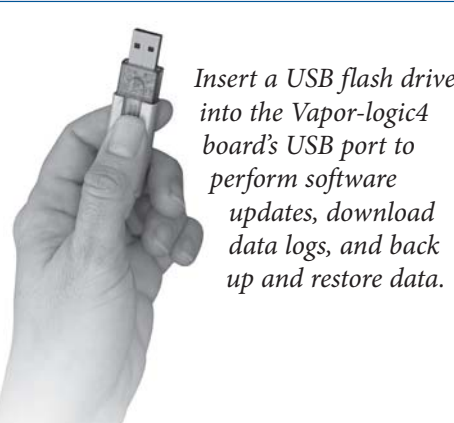
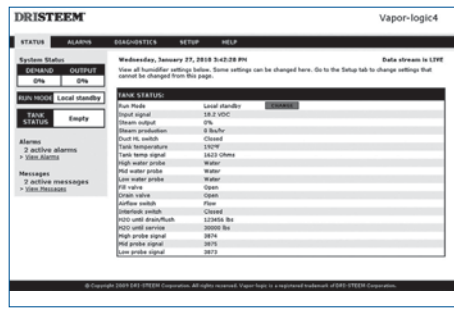
- 316 stainless steel construction
- Evaporating chamber insulation
- NEMA-4 control cabinet

# Vapor-logic4 controller

## Keypad/display



## Web interface



## Accurate, responsive control

The Vapor-logic4 controller provides accurate, responsive RH control. PID control tunes the system for maximum performance.

**Modbus, BACnet, or LonTalk** allow interoperability with multiple building automation systems. Modbus is standard, and BACnet or LonTalk are available options.

**Web interface** provides the capability to set up, view, and adjust humidifier functions via Ethernet, either directly or remotely through a network.

**Contactor wear leveling** distributes cycles among multiple contactors for equal wear and longer contactor life.

**Cycle counter** triggers a message when it's time to replace contactors.

**USB port** allows easy firmware updates, and data backup and restore capability.

**Real-time clock** allows time-stamped alarm and message tracking, and accurate drain and flush scheduling.

**Auxiliary temperature sensor/transmitter** allows air temperature monitoring, such as in a duct, and enables temperature compensation to prevent window condensation.

**Programmable outputs** allow remote signaling and device activation.

**Multiple-humidifier control** allows staged control of up to 16 humidifiers with one controller.

**Controller data**, such as RH, air temperature, water use, energy use, alarms, and messages, can be downloaded to a PC for viewing and analysis. RH, alarms, and service messages can also be displayed via the keypad or Web interface..

**Enhanced diagnostics** include:

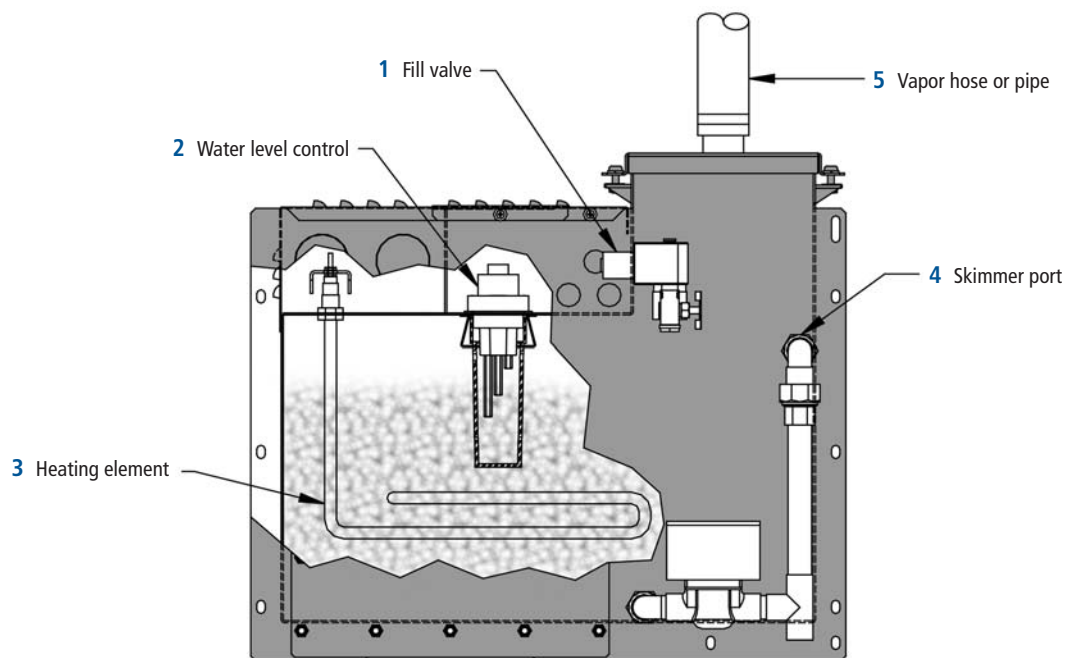
- **Test outputs** function using keypad or Web interface to verify component operation
- **Test humidifier** function using simulated demand to validate performance

mc\_042710\_1500-VLC

## Vaporstream principle of operation

**Figure 5-1:**  
**Vaporstream principle of operation**

Tap/softened water system shown



VLC-OM-002

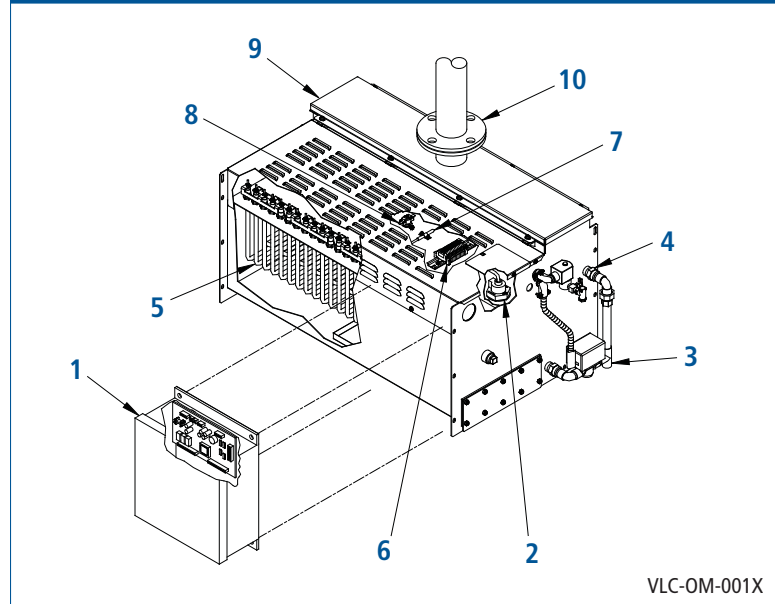
1. When the system is first activated, the fill valve opens and the evaporating chamber fills with water to the operating level.
2. The operating level is maintained by the water level control.
3. On a call for humidity, the heating elements are energized, causing the water to boil. The fill valve opens and closes as needed to maintain the operating water level.
4. During refill in tap/softened water systems, a portion of the surface water is skimmed off, carrying away precipitated minerals.  
DI/RO water systems (systems using deionized water or water that has been treated using reverse osmosis) do not require skimming.
5. Steam created in the evaporating chamber flows through vapor hose or piping to the dispersion assembly, where it is discharged into the airstream.

## Vaporstream components

**Figure 6-1:**  
Vapor-logic4 keypad/display



**Figure 6-2:**  
Vaporstream components



VLC-OM-001X

### 1. Vapor-logic4 controller

Vapor-logic4 controls all humidifier functions and can connect to a building automation system via Modbus or optional BACnet or LonTalk. See Page 4 for more information.

### 2. Water level control

Tap/softened water systems control water levels electronically using a three-rod probe (Figure 7-1).

Systems with the DI/RO water option control water levels using a float valve (Figure 7-2) and low-water cutoff switch.

### 3. Drain

Duration and frequency of draining are user adjustable. To avoid possible stagnant water and microbial growth, the humidifier automatically drains if there is no call for humidity after a user-defined time period (72-hour default).

### 4. Water skimmer/overflow port

In tap/softened water systems, the water skimmer reduces surface minerals in the evaporating chamber. Skimming occurs each time the humidifier fills. The skim time duration is user-adjustable.

In systems with the DI/RO water option, skimming is not required; the skimmer port functions as an overflow port.

## Vaporstream components

### 5. Heating elements

Low-watt-density Incoloy-sheathed heating elements ensure operation for many seasons. Constant expansion and contraction of heating elements sheds mineral scale. In the unlikely event of heater failure, heating elements can be removed easily.

### 6. Terminal strip

All control wiring connections at the humidifier can be made in this single location.

### 7. Temperature sensor

Mounted on the evaporating chamber, this sensor enables:

- Over-temperature protection
- Freeze protection
- Preheating, allowing rapid response to a call for humidity

### 8. Over-temperature thermostat

This safety device shuts down the humidifier if it becomes too hot. This is one of three levels of safety protection that also includes the temperature sensor and the water level control system.

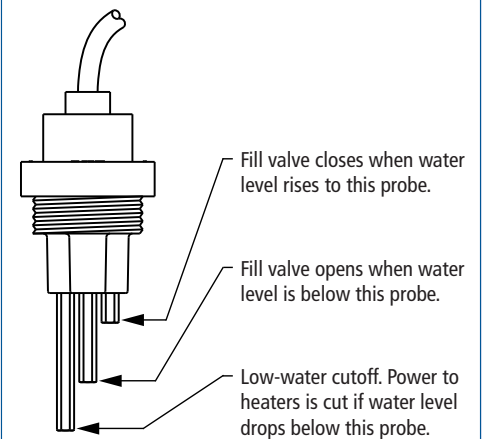
### 9. Service access

Access cover allows periodic inspection and servicing of the evaporating chamber.

### 10. Steam outlet

Steam generated in the humidifier rises through the steam outlet and travels to the dispersion assembly through vapor hose or piping.

**Figure 7-1:**  
Water level control for tap/softened water humidifier

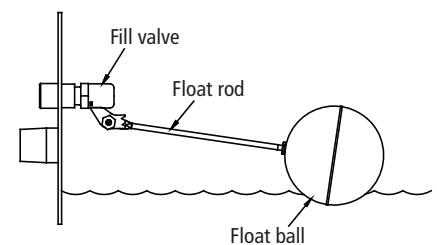


Humidifiers using tap or softened water control water levels electronically using a three-rod probe. The controller responds with the above actions when the water level reaches each rod.

mc\_030910\_1335

VLC-OM-030

**Figure 7-2:**  
Water level control for DI/RO-water option humidifier



Humidifiers using DI/RO water control water levels using a float valve and low-water cutoff switch.

mc\_030910\_1336

VLC-OM-026

# Vaporstream capacities and electrical specifications

**Table 8-1:**  
Vaporstream VLC capacities and electrical specifications, tap/softened water and DI/RO water

Model (kW- stages)	Maximum steam capacity †		Heaters		Current draw (amps)											kW
					Single-phase						Three-phase***					
	lbs/hr	kg/h	Qty.	Stages**	120V	208V*	240V*	277V*	480V*	600V*	208V*	240V*	277V*	480V*	600V*	
2-1	5.7	2.6	1	1	16.7	9.6	8.3	7.2	4.2	3.3	—	—	—	—	—	2
3-1	8.6	3.9	1	1	25.0	14.4	12.5	10.8	6.3	5.0	—	—	—	—	—	3
4-1	11.4	5.2	1	1	33.3	19.2	16.7	14.4	8.3	6.7	—	—	—	—	—	4
5-1	15.2	6.9	1	1	44.4	25.6	22.2	19.2	11.1	8.9	—	—	—	—	—	5.33
6-1	17.1	7.8	3	1	—	28.8	25.0	21.7	12.5	10.0	16.7	14.4	12.5	7.2	5.8	6
9-1	25.7	11.7	3	1	—	43.3	37.5	32.5	18.8	15.0	25.0	21.7	18.8	10.8	8.7	9
12-1	34.2	15.5	3	1	—	—	—	43.3	25.0	20.0	33.3	28.9	25.0	14.4	11.5	12
16-1	45.6	20.7	3	1	—	—	—	—	33.3	26.7	44.4	38.5	33.3	19.2	15.4	16
21-1	59.9	27.2	3	1	—	—	—	—	43.8	35.0	—	—	43.8	25.3	20.2	21
25-1	71.3	32.3	3	1	—	—	—	—	—	41.7	—	—	—	30.1	24.1	25
12-2	34.2	15.5	6	2	—	57.7	50.0	43.3	25.0	20.0	33.3	28.9	25.0	14.4	11.5	12
18-2	51.3	23.3	6	2	—	86.5	75.0	65.0	37.5	30.0	50.0	43.3	37.5	21.7	17.3	18
24-2	68.4	31.0	6	2	—	—	—	86.6	50.0	40.0	66.6	57.7	50.0	28.9	23.1	24
32-2	91.2	41.4	6	2	—	—	—	—	66.7	53.3	88.8	77.0	66.7	38.5	30.8	32
42-2	119.7	54.3	6	2	—	—	—	—	87.5	70.0	—	—	87.5	50.5	40.4	42
50-2	142.5	64.6	6	2	—	—	—	—	—	83.3	—	—	—	60.1	48.1	50
18-3	51.3	23.3	9	3	—	86.5	75.0	65.0	37.5	30.0	50.0	43.3	37.5	21.7	17.3	18
27-3	77.0	34.9	9	3	—	129.8	112.5	97.5	56.3	45.0	74.9	65.0	56.3	32.5	26.0	27
36-3	102.6	46.5	9	3	—	—	—	130.0	75.0	60.0	99.9	86.6	75.0	43.3	34.6	36
48-3	136.8	62.1	9	3	—	—	—	—	100.0	80.0	133.2	115.5	100.0	57.7	46.2	48
63-3	179.6	81.5	9	3	—	—	—	—	131.3	105.0	—	—	131.3	75.8	60.6	63
75-3	213.8	97.0	9	3	—	—	—	—	—	125.0	—	—	—	90.2	72.2	75
24-4	68.4	31.0	12	4	—	115.4	100.0	86.6	50.0	40.0	66.6	57.7	50.0	28.9	23.1	24
36-4	102.6	46.5	12	4	—	173.1	150.0	130.0	75.0	60.0	99.9	86.6	75.0	43.3	34.6	36
48-4	136.8	62.1	12	4	—	—	—	173.3	100.0	80.0	133.2	115.5	100.0	57.7	46.2	48
64-4	182.4	82.7	12	4	—	—	—	—	133.3	106.7	177.6	154.0	133.4	77.0	61.6	64
84-4	239.4	108.6	12	4	—	—	—	—	175.0	140.0	—	—	175.1	101.0	80.8	84
100-4	285.0	129.3	12	4	—	—	—	—	—	166.7	—	—	—	120.3	96.2	100

\* If using an optional SDU or Area-type fan unit for dispersion, run a neutral line with 208V/240V/single-phase and 208V/three-phase power supply lines to provide a 120V circuit for the fan. With all other power supply voltages (other than 120V), provide a separate 120V circuit for the fan, or order from DRI-STEEM a transformer installed in the control cabinet.

\*\* Heater stage identifies the number of contactors.

\*\*\* Three-phase power supply connection. All heater loads are wired Delta.

† Total humidifier load = load to meet design conditions + load to compensate for steam loss from the dispersion assembly and interconnecting piping. If total humidifier load is more than the humidifier's maximum capacity, design conditions will not be met. For steam loss data see the *DRI-STEEM Design Guide* available for downloading and printing at [www.drirsteem.com](http://www.drirsteem.com)

# Vaporstream weights and cabinet sizes

**Table 9-1:  
Vaporstream VLC weights and control cabinet sizes, tap/softened water and DI/RO water**

Model (kW-stages)	Shipping weight		Operating weight †		Control cabinet size* (M, L, XL, XXL)										
	lbs	kg	lbs	kg	Single-phase power						Three-phase power				
					120V	208V	240V	277V	480V	600V	208V	240V	277V	480V	600V
2-1	35	16	79	36	M	M	M	M	M	M	—	—	—	—	—
3-1	35	16	79	36	M	M	M	M	M	M	—	—	—	—	—
4-1	35	16	79	36	M	M	M	M	M	M	—	—	—	—	—
5-1	35	16	79	36	M	M	M	M	M	M	—	—	—	—	—
6-1	57	26	157	71	—	M	M	M	M	M	M	M	M	M	M
9-1	57	26	157	71	—	M	M	M	M	M	M	M	M	M	M
12-1	57	26	157	71	—	—	—	M	M	M	M	M	M	M	M
16-1	57	26	157	71	—	—	—	—	M	M	M	M	M	M	M
21-1	57	26	157	71	—	—	—	—	M	M	—	—	M	M	M
25-1	57	26	157	71	—	—	—	—	—	M	—	—	—	M	M
12-2	79	36	237	108	—	L	L	L	L	L	L	L	L	L	L
18-2	79	36	237	108	—	L	L	L	L	L	L	L	L	L	L
24-2	79	36	237	108	—	—	—	L	L	L	L	L	L	L	L
32-2	79	36	237	108	—	—	—	—	L	L	L	L	L	L	L
42-2	79	36	237	108	—	—	—	—	L	L	—	—	L	L	L
50-2	79	36	237	108	—	—	—	—	—	L	—	—	—	L	L
18-3	110	50	326	148	—	L	L	L	L	L	L	L	L	L	L
27-3	110	50	326	148	—	XL	L	L	L	L	L	L	L	L	L
36-3	110	50	326	148	—	—	—	XL	L	L	L	L	L	L	L
48-3	110	50	326	148	—	—	—	—	L	XXL	XL	L	L	L	L
63-3	110	50	326	148	—	—	—	—	XL	XXL	—	—	L	L	L
75-3	110	50	326	148	—	—	—	—	—	XXL	—	—	—	L	XXL
24-4	153	70	427	194	—	L	L	L	L	L	L	L	L	L	L
36-4	153	70	427	194	—	XL	XL	XL	L	L	L	L	L	L	L
48-4	153	70	427	194	—	—	—	XL	L	L	XL	L	L	L	L
64-4	153	70	427	194	—	—	—	—	XL	XXL	XL	XL	XL	L	L
84-4	153	70	427	194	—	—	—	—	XL	XXL	—	—	XL	L	L
100-4	153	70	427	194	—	—	—	—	—	XXL	—	—	—	L	XXL

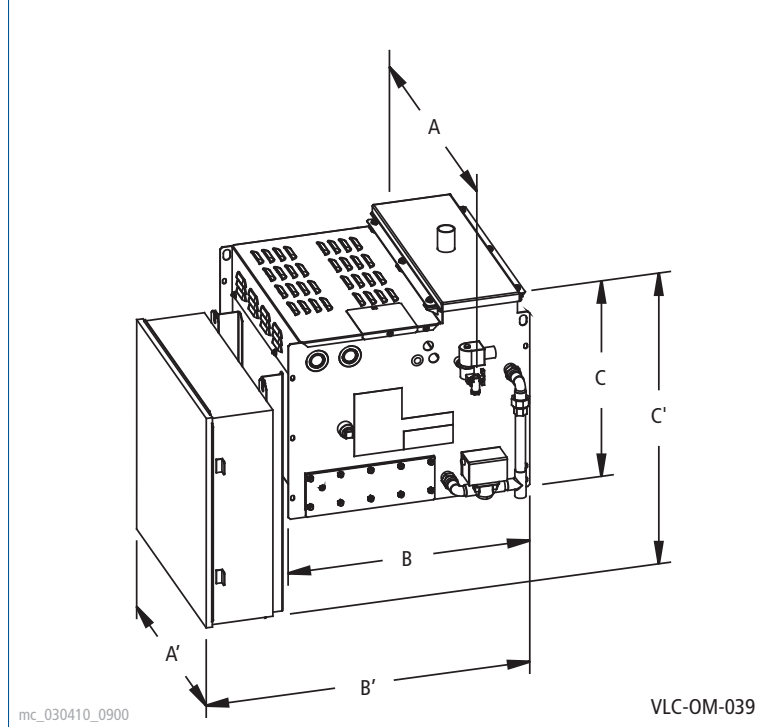
\* Control cabinet sizes in this table are for the largest required cabinet for each model. Depending on Vaporstream options chosen you may receive a smaller cabinet than the one shown in this table. Contact DRI-STEEM if you need more detailed information about control cabinet sizes. See control cabinet dimensions in the next section.

† Operating weight does not include control cabinet. See control cabinet weights in the next section.

mc\_021010\_0446

# Vaporstream dimensions

**Figure 10-1:**  
Vaporstream VLC dimensions, tap/softened water and DI/RO water



**Table 10-1:**  
Vaporstream VLC dimensions, tap/softened water and DI/RO water

Model (kW - stages)	Without mounted control cabinet						
	A (length)		B (width)		C (height)		
	inches	mm	inches	mm	inches	mm	
2-1, 3-1, 4-1, 5-1	12.52	318	26.00	660	18.88	480	
6-1, 9-1, 12-1, 16-1, 21-1, 25-1	17.85	453	22.00	559	18.88	480	
12-2, 18-2, 24-2, 32-2, 42-2, 50-2	25.35	644	22.00	559	18.88	480	
18-3, 27-3, 36-3, 48-3, 63-3, 75-3	32.85	834	22.00	559	18.88	480	
24-4, 36-4, 48-4, 64-4, 84-4, 100-4	40.35	1025	22.00	559	18.88	480	
Model (kW - stages)	Max. control cabinet size	With mounted control cabinet option					
		A' (length 2)		B' (width 2)		C' (height 2)	
		inches	mm	inches	mm	inches	mm
2-1, 3-1, 4-1, 5-1	M	14.75	375	34.00	864	30.31	770
6-1, 9-1, 12-1, 16-1, 21-1, 25-1	M	25.00	635	30.00	762	30.31	770
12-2, 18-2, 24-2, 32-2, 42-2, 50-2	L	29.00	737	30.00	762	34.11	866
18-3, 27-3, 36-3, 48-3, 63-3, 75-3	XXL	32.85	834	32.00	813	46.11	1171
24-4, 36-4, 48-4, 64-4, 84-4, 100-4	XXL	40.35	1025	32.00	813	46.11	1171

**Notes:**

- For all Vaporstream models with optional insulation, add 1" (25 mm) to dimensions A, C, and C'.
- Dimensions are largest possible for these models. Actual dimensions may be smaller.

mc\_021010\_0500

## Vaporstream control cabinets

### Control cabinet features

The standard Vaporstream control cabinet is an ETL- and C-ETL-listed NEMA-12 cabinet and is shipped loose. Control cabinet options include:

- Factory mounting on humidifier
- NEMA-4 cabinet
- Cabinet door interlock switch
- Cabinet door lock

The control cabinet's size is based on capacity and system options. See Table 11-1 below and Table 9-1 for cabinet sizing by model.

The control cabinet can be mounted up to 50' (15 m) from the Vaporstream. The keypad can be mounted up to 500' (152 m) from the control cabinet. (Distances are based on wire/cable lengths.)

**Figure 11-1:**  
Vaporstream model 6-1 with mounted control cabinet



**Table 11-1:**  
Standard control cabinet dimensions and weights

Cabinet size	Cabinet dimensions		Shipping weight*	
	inches	mm	lbs	kg
S	16 h x 14 w x 6 d	406 h x 356 w x 152 d	32	15
M	20 h x 20 w x 7 d	508 h x 508 w x 178 d	55	25
L	24 h x 24 d x 7 d	610 h x 610 w x 178 d	73	33
XL	30 h x 24 w x 9 d	762 h x 610 w x 229 d	91	41
XXL	36 h x 30 w x 9 d	914 h x 762 w x 229 d	136	62

\* Weight does not include humidifier.

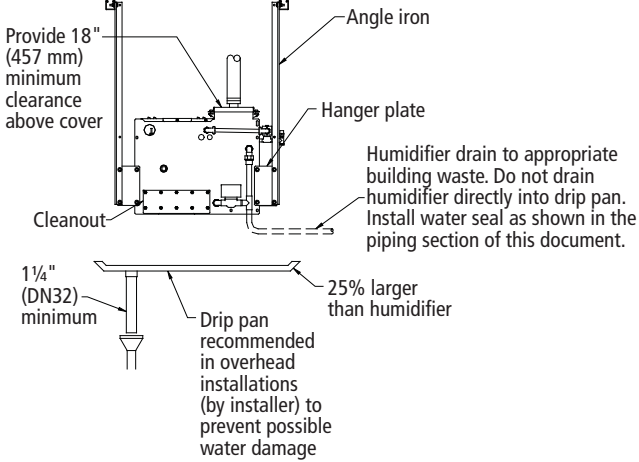
mc\_021010\_0555

# Vaporstream mounting

**Figure 12-1:**  
Trapeze hanger

**Vaporstream Models 2-1 through 5-1**

Secure channel to an overhead structure that is strong enough to support the Vaporstream's operating weight. See the weight tables in this document.

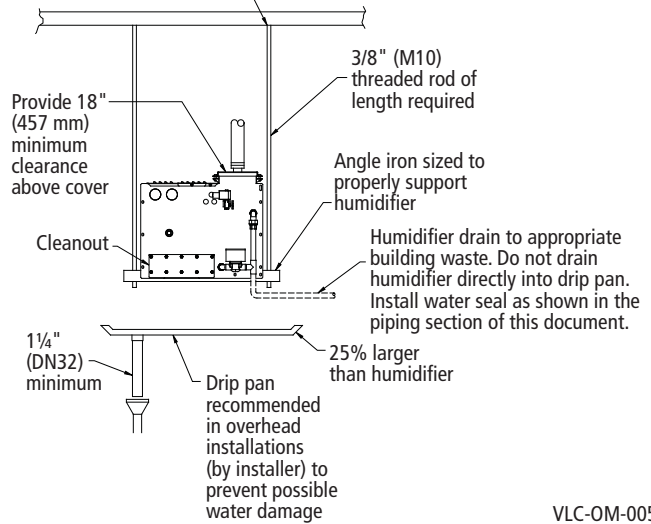


mc\_022310\_1400

VLC-OM-038

**Vaporstream Models 6-1 through 100-4**

Secure rods to an overhead structure that is strong enough to support the Vaporstream's operating weight. See the weight tables in this document.



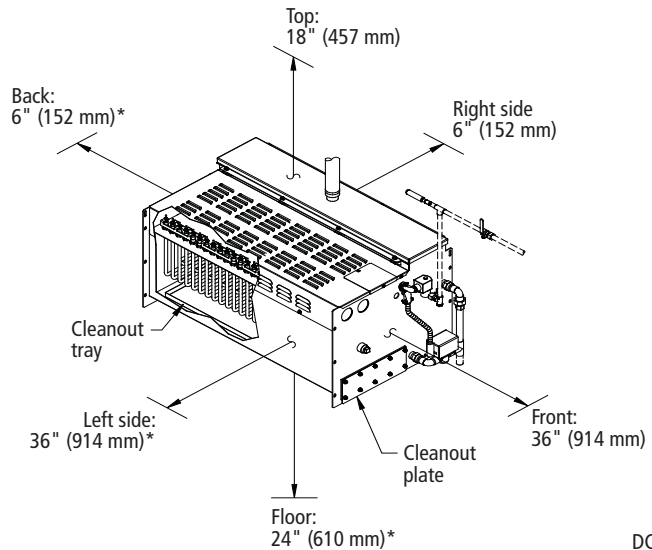
VLC-OM-005

**Table 12-1:**  
Mounting options by model

Mounting method	Models			
	2-1, 3-1, 4-1, 5-1		All other models	
	Standard	Optional	Standard	Optional
Trapeze	X		X	
Support legs				X
Wall brackets	X			X
Weather cover		X		X
Outdoor enclosure		X		X

mc\_022310\_1354

**Figure 12-2:**  
Vaporstream clearance recommendations



DC-1181

\* When the control cabinet is mounted on the Vaporstream, provide 36" (914 mm) clearance from the front of the control cabinet and 6" (152 mm) from the bottom of the cabinet to the floor.

mc\_022310\_1350

# Vaporstream mounting

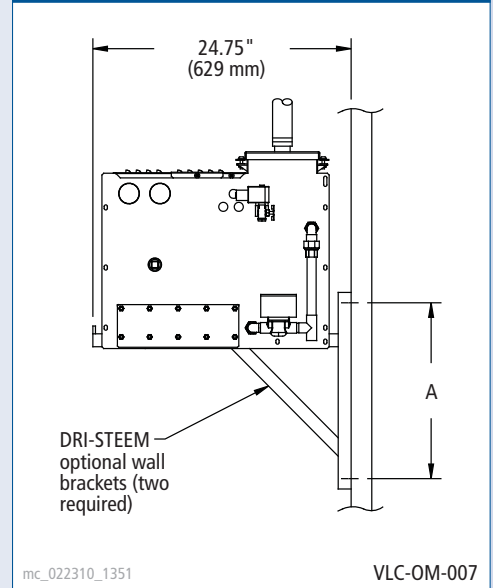
**Table 13-1:  
Wall brackets Dimension A (center to center of mounting holes)**

Vaporstream model	inches	mm
One-heater models: 2-1, 3-1, 4-1, 5-1	17	432
Three-heater models: 6-1, 9-1, 12-1, 16-1, 21-1, 25-1	17	432
Six-heater models: 12-2, 18-2, 24-2, 32-2, 42-2, 50-2	17	432
Nine-heater models*: 18-3, 27-3, 36-3, 48-3, 63-3, 75-3	28	711
Twelve-heater models*: 24-4, 36-4, 48-4, 64-4, 84-4, 100-4	34	864

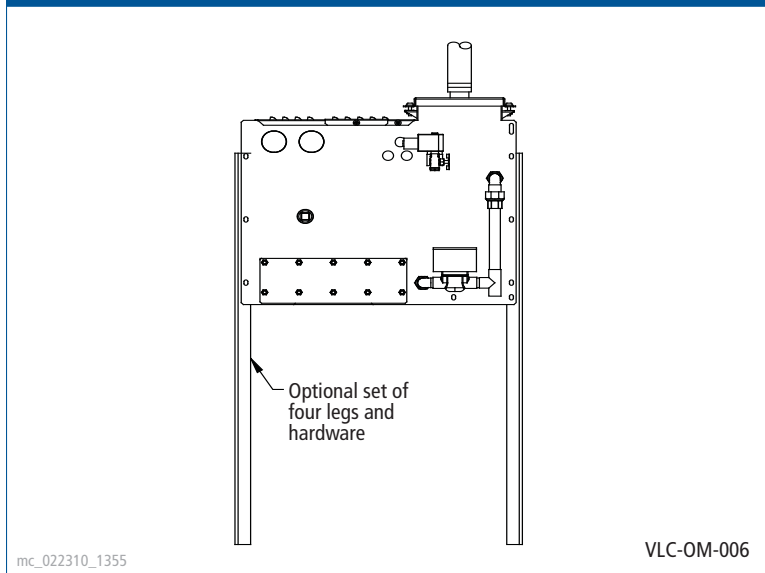
\* Wall bracket installation on metal stud walls is not recommended for nine-heater and twelve-heater models.

mc\_022310\_1345

**Figure 13-1:  
Wall brackets**

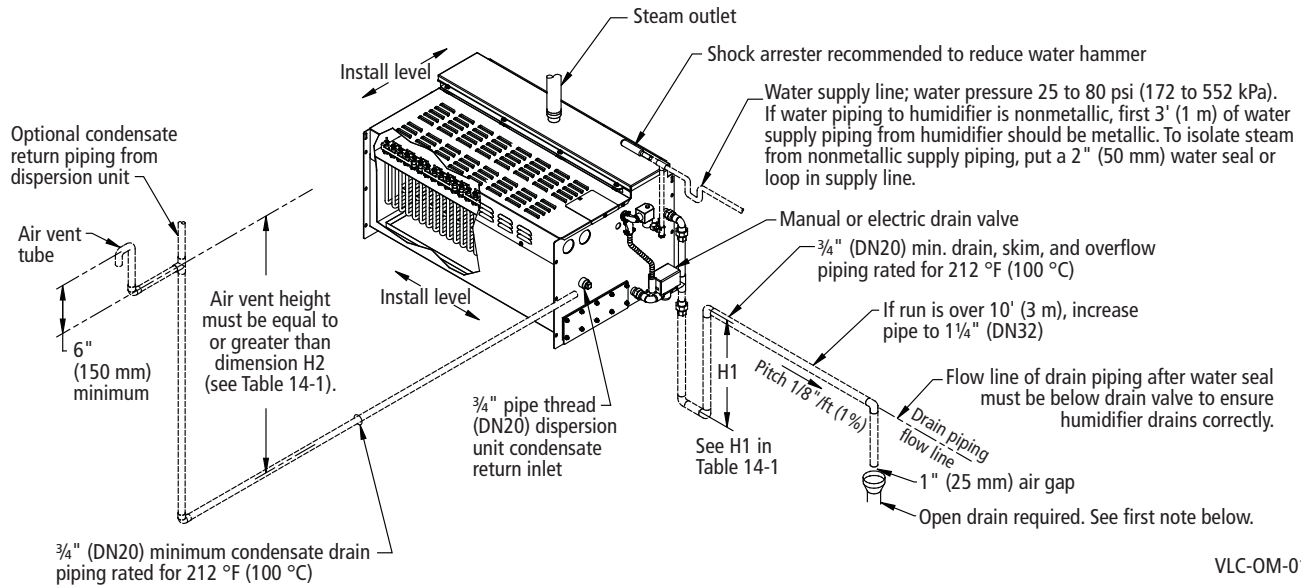


**Figure 13-2:  
Support legs**



# Vaporstream piping: Tap/softened water

**Figure 14-1:**  
Field piping overview, Vaporstream VLC with tap/softened water



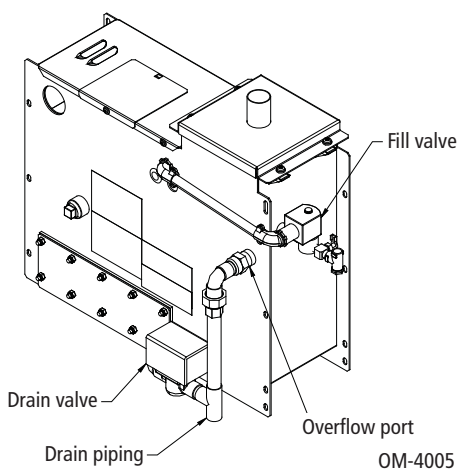
VLC-OM-010

**Notes:**

- Locate air gap only in spaces with adequate temperature and air movement to absorb flash steam; otherwise, condensation may form on nearby surfaces. Refer to governing codes for drain pipe size and maximum discharge water temperature.
- Offset humidifier from floor drain to prevent flash steam from rising into the humidifier.
- Dashed lines indicate provided by installer.
- The water supply inlet is more than 1" (25 mm) above the skim/overflow port, eliminating the possibility of backflow or siphoning from the tank. No additional backflow prevention is required; however, governing codes prevail.
- Damage caused by chloride corrosion is not covered by your DRI-STEEM warranty.

mc\_022310\_1255

**Figure 14-2:**  
Piping, Vaporstream VLC with tap/  
softened water, Models 2-1 through 5-1



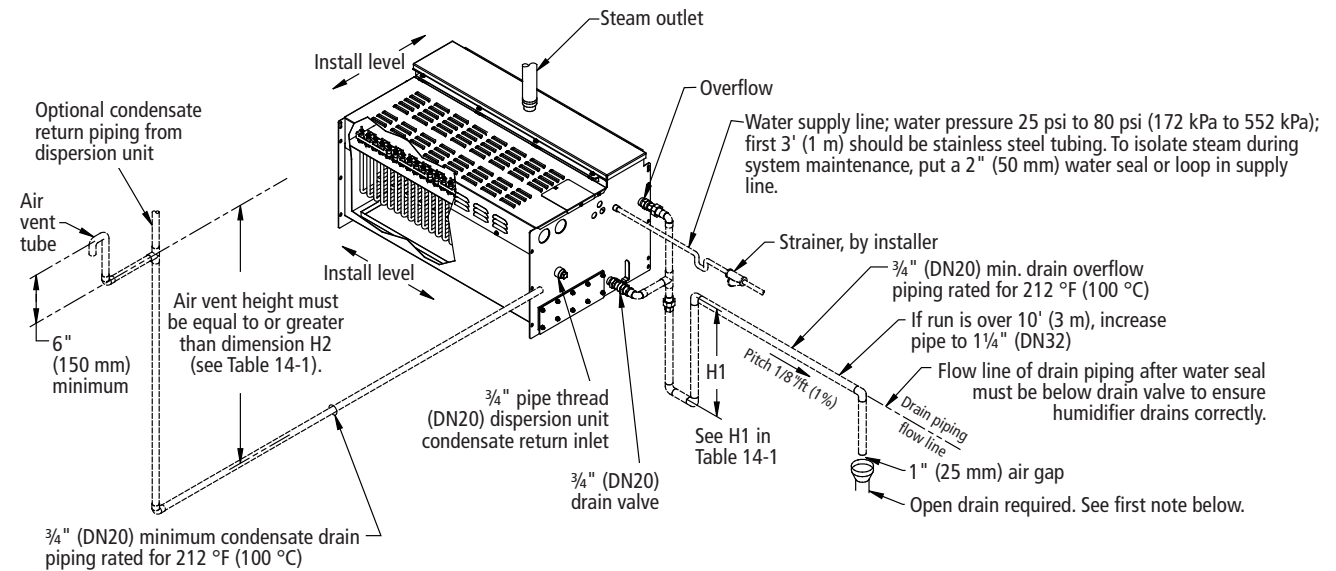
**Table 14-1:**  
Heights required to overcome Vaporstream internal pressure  
(H1, H2)

Unit output			Water seal height (H1)		Air vent height (H2)	
kW	lbs/hr	kg/h	inches	mm	inches	mm
≤ 48	≤ 138	≤ 62	12	305	22.5	572
49-64	139-183	63-83	15	381	27.5	699
> 64	> 183	> 83	18	457	30.5	775

mc\_022310\_1325

# Vaporstream piping: DI/RO water option

**Figure 15-1:**  
Field piping overview, Vaporstream VLC with DI/RO water option



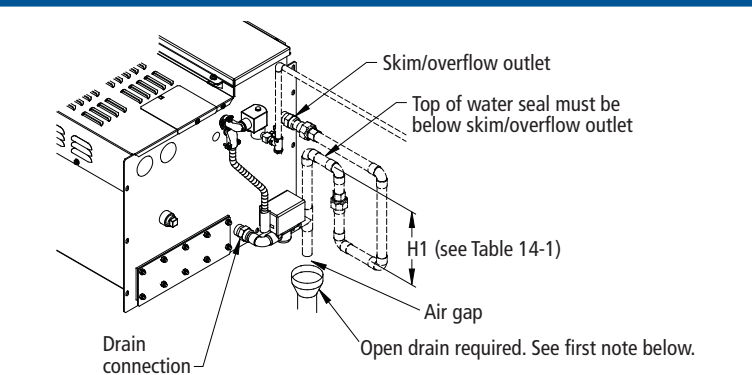
VLC-OM-011

**Notes:**

- Locate air gap only in spaces with adequate temperature and air movement to absorb flash steam; otherwise, condensation may form on nearby surfaces. Refer to governing codes for drain pipe size and maximum discharge water temperature.
- Offset humidifier from floor drain to prevent flash steam from rising into the humidifier.
- Dashed lines indicate provided by installer.
- The water supply inlet is more than 1" (25 mm) above the overflow port, eliminating the possibility of backflow or siphoning from the tank. No additional backflow prevention is required; however, governing codes prevail.
- Damage caused by chloride corrosion is not covered by your DRI-STEEM warranty.

mc\_022310\_1300

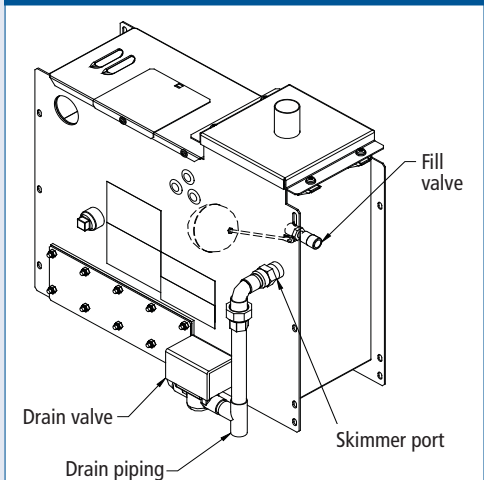
**Figure 15-2:**  
Alternate water seal and drain valve piping



**Notes:** VLC-OM-012

- Locate air gap only in spaces with adequate temperature and air movement to absorb flash steam; otherwise, condensation may form on nearby surfaces. Refer to governing codes for drain pipe size and maximum discharge water temperature.
- Use this piping configuration when water seal must be elevated above flow line of drain connection, such as when the humidifier is mounted near the floor.
- Dashed lines indicate provided by installer

**Figure 15-3:**  
Piping, Vaporstream VLC with DI/RO water, Models 2-1 through 5-1



OM-4004

## Vaporstream outdoor enclosure overview

**Figure 16-1:**  
**Outdoor enclosure**



Install a Vaporstream humidifier virtually anywhere. This pre-packaged, factory-installed unit ships complete to the job site, ready for easy-to-connect water and electrical connections.

Outdoor humidifier operation in any climate is possible with the DRI-STEEM outdoor enclosure. The prepiped, factory-assembled unit ships complete to the job site. Installation is a snap with various mounting options — curb, legs, or flush.

**Factory constructed and assembled.** The outdoor enclosure is shipped complete with the humidifier preinstalled and tested. The humidifier is prepiped within the enclosure with an integral water seal, ready for quick connection to water, steam and electricity.

**Install on the ground or on the roof.** Outdoor enclosures are ideal for facilities that have limited interior space.

**Certified, tested and proven.** In-house testing and numerous successful installations have proven that the outdoor enclosure provides reliable operation under extreme conditions.

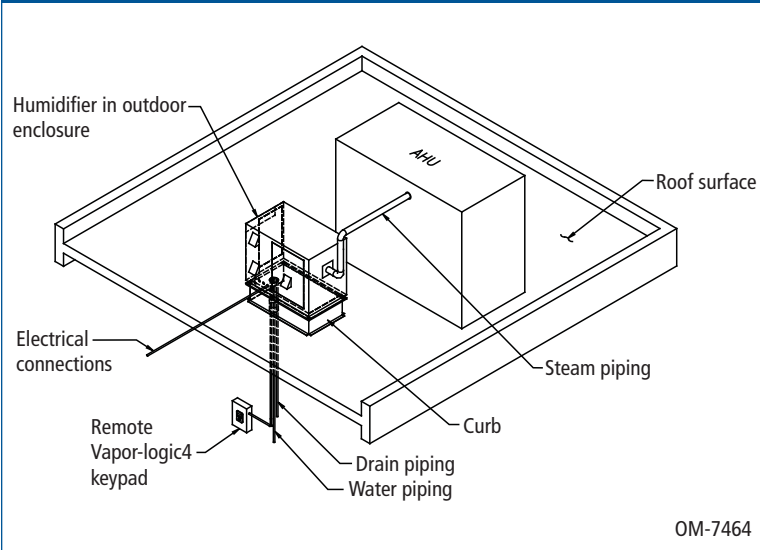
**Easy access for service.** Steel enclosure doors provide full access to internal components. The doors feature stainless steel hinges, and the latches operate from outside and inside of the unit.

**Protects in cold and hot climates.** To ensure complete safety and operation in all climates, the outdoor enclosure has supplemental heating and ventilating systems that automatically maintain required operation conditions. DRI-STEEM humidifiers housed in outdoor enclosures operate properly when outdoor temperatures range from  $-40^{\circ}\text{F}$  to  $122^{\circ}\text{F}$  ( $-40^{\circ}\text{C}$  to  $50^{\circ}\text{C}$ ).

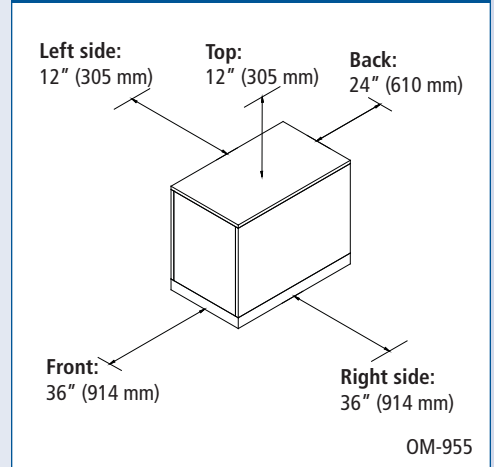
**Robust design.** The outdoor enclosure is ruggedly built to completely protect internal components. The enclosure is constructed of heavy-duty galvanized steel and is fully insulated. Gaskets on doors ensure a tight seal.

# Vaporstream outdoor enclosure

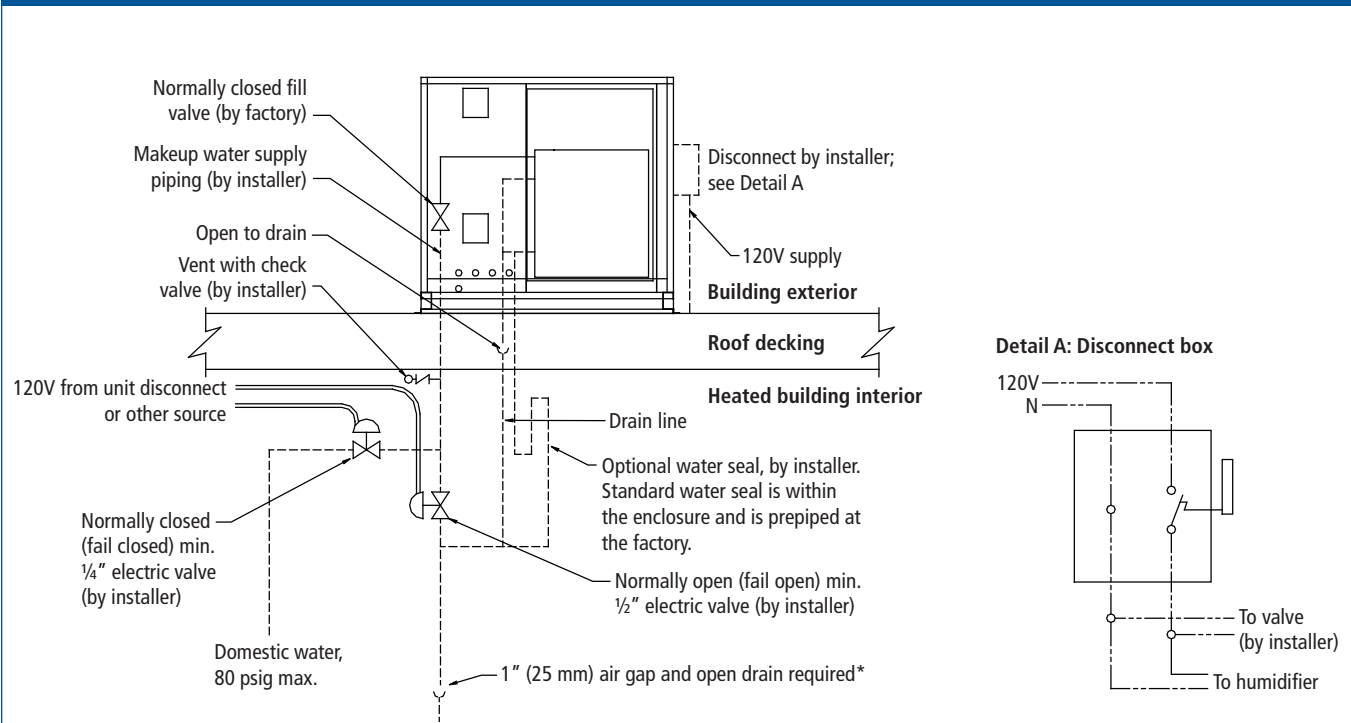
**Figure 17-1:**  
Typical rooftop installation overview



**Figure 17-2:**  
Outdoor enclosure clearances



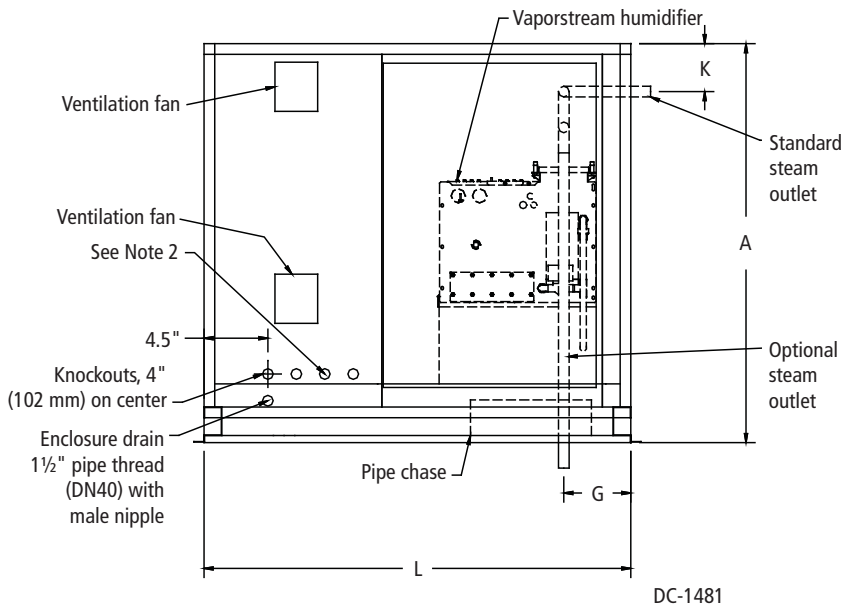
**Figure 17-3:**  
Optional installation method for water supply piping



\* Locate air gap only in spaces with adequate temperature and air movement to absorb flash steam; otherwise, condensate may form on nearby surfaces. Refer to governing codes for drain pipe size and maximum discharge water temperature.

# Vaporstream outdoor enclosure

**Figure 18-1:**  
Vaporstream outdoor enclosure with standard or optional steam outlet, elevation view



**Notes:**

- The outdoor enclosure has two available steam distribution configurations:  
The standard configuration has a steam outlet at the back of the outdoor enclosure for connecting to steam dispersion unit piping.  
The optional internal steam distribution configuration routes steam within the outdoor enclosure and down through the enclosure pipe chase into a building.
- There are four knockouts located on the right and left side of the enclosure. Knockout sizes are 1½" (hole dia. 50 mm) for Vaporstream models with 1-6 heaters and 2" (hole dia. 63.5 mm) for Vaporstream models with 9-12 heaters. Run the electrical power into the enclosure at these knockouts.
- All piping from the Vaporstream unit to the steam outlet is stainless steel pipe. Depending on the application, interconnecting piping from the steam outlet to the dispersion assembly can be tubing, pipe or DRI-STEEM vapor hose. See the *Dispersion* section of this document for more information about connecting to the dispersion assembly.
- A separate 15 amp, 120 VAC service must be brought to the outdoor enclosure to power the enclosure heaters and fans.

mc\_030410\_1500

**Table 18-1:**  
Vaporstream outdoor enclosure dimensions\*

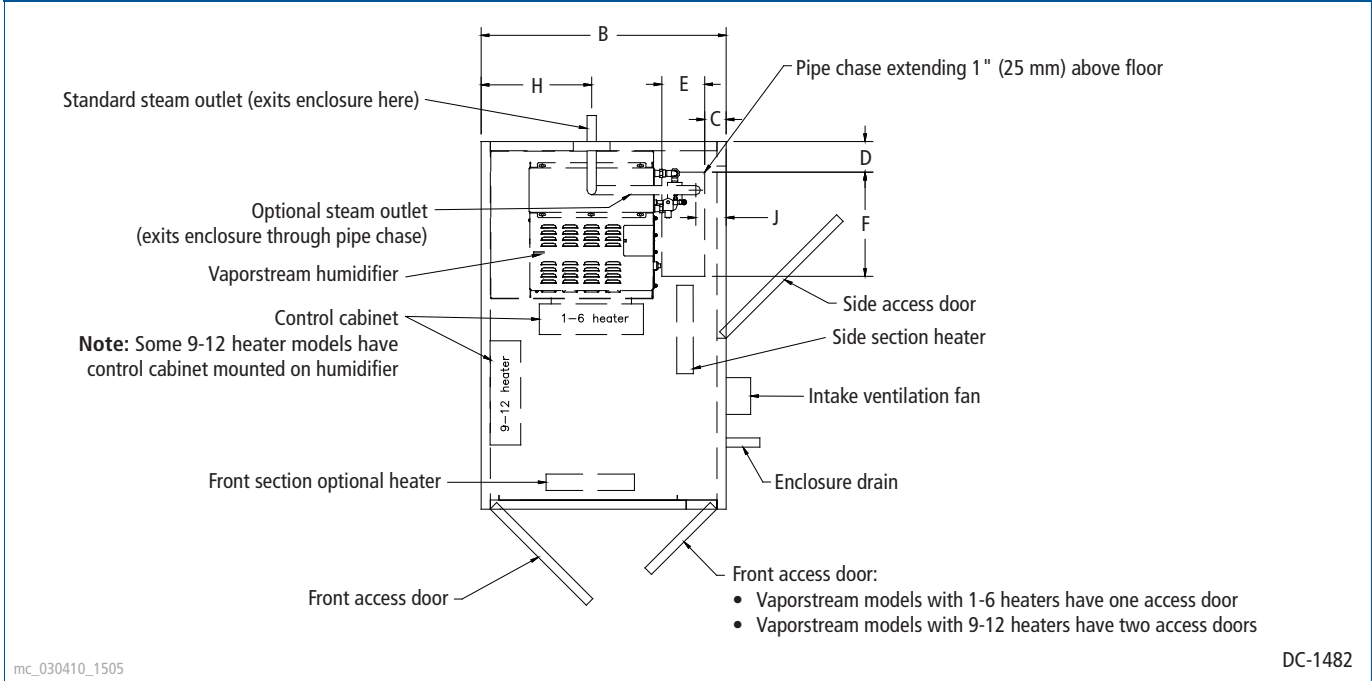
Item	Description	Vaporstream models			
		with 1-6 heaters		with 9-12 heaters	
		inches	mm	inches	mm
A	Enclosure height	56.00	1422	56.00	1422
B	Enclosure width	40.00	1016	54.00	1372
C	Pipe chase position	2.50	67	2.50	67
D		2.50	64	2.50	64
E	Pipe chase size	8.00	203	8.00	203
F		19.50	495	19.50	495
G		13.50	343	13.50	343
H	Steam pipe position	22.00	559	29.50	899
J		7.00	178	7.00	178
K		8.25	210	9.25	235
L	Length	60.00	1524	64.00	1626

\* See drawings above and on facing page.

mc\_030410\_1520

# Vaporstream outdoor enclosure

**Figure 19-1:**  
Vaporstream outdoor enclosure, top view



**Table 19-1:**  
Vaporstream outdoor enclosure connection sizes

Description	All Vaporstream models
Water makeup (fill)	¼" pipe thread (DN8)
Drain	¾" (DN20)
Condensate return	¾" pipe thread (DN20)

mc\_030410\_1101

**Notes:**

- See Table 8-1 for capacities and input requirements.
- Add 15 full load amps (120 VAC) when using an outdoor enclosure with a heater package.
- Add 2 full load amps (120 VAC) when using an outdoor enclosure without a heater package.

**Table 19-2:**  
Vaporstream outdoor enclosure weights

Vaporstream model	Number of heaters	Outdoor enclosure shipping weight*		Outdoor enclosure operating weight*	
		lbs	kg	lbs	kg
2-1, 3-1, 4-1, 5-1	1	485	220	530	240
6-1, 9-1, 12-1, 16-1, 21-1, 25-1	3	515	234	620	281
12-2, 18-2, 24-2, 32-2, 42-2, 50-2	6	535	243	690	313
18-3, 27-3, 36-3, 48-3, 63-3, 75-3	9	860	390	1090	494
24-4, 36-4, 48-4, 64-4, 84-4, 100-4	12	910	413	1190	540

\* Includes humidifier

mc\_030410\_1100

## Vaporstream weather cover

**Table 20-1:  
Weather cover weights**

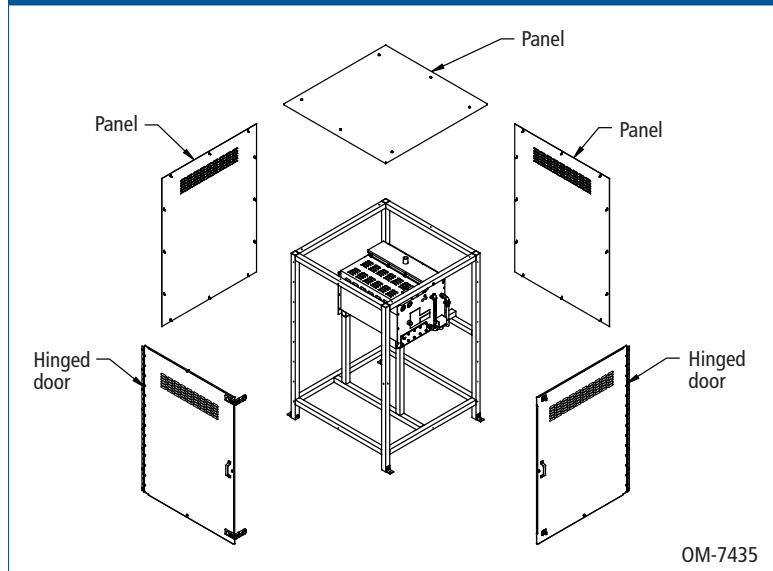
Weather cover size	Weight*	
	lbs	kg
1-heater	390	177
3-heater	395	179
6-heater	430	195
9-heater	465	211
12-heater	500	227

\* Weight does not include humidifier or control cabinet.

mc\_030210\_0950

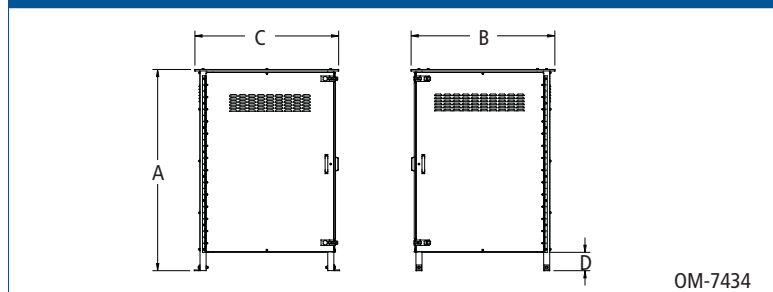
The optional Vaporstream weather cover is water-resistant and designed to protect the humidifier from rain and sun. The weather cover has been tested and approved by ETL Testing Laboratories, Inc., and is listed to UL Standard 1995 and certified to CAN/CSA Standard C22.2 No. 236.

**Figure 20-1:  
Weather cover exploded view**



mc\_020110\_1255

**Figure 20-2:  
Weather cover dimensions**



**Table 20-2:  
Weather cover dimensions**

Letter	Description	1-heater and 3-heater covers		6-heater cover		9-heater cover		12-heater cover	
		inches	mm	inches	mm	inches	mm	inches	mm
A	Height	66	1676	66	1676	66	1676	66	1676
B	Length	44	1118	44	1118	44	1118	44	1118
C	Width	35	889	39	991	44	1118	50	1270
D	Distance from bottom	6	152	6	152	6	152	6	152

mc\_022310\_1645

## Drip-free dispersion basics

### Guaranteed non-wetting distances

Using data collected in our on-site test lab, we have developed guaranteed steam absorption (non-wetting) distances. Performance charts allow you to confidently choose equipment that will accommodate any application.

### Dry steam

Adding humidification to an airstream without creating wetness in the duct system is critical for the maintenance of a healthy environment. Wet areas in ducts are a threat to the health of building occupants since they moisten dust on duct floors, creating ideal breeding grounds for disease-producing microbes. In addition, water accumulating in ducts can drip and cause building damage.

### Steam exits drip-free through tubelets

All DRI-STEEM evaporative dispersion tube units discharge steam through thermal-resin tubelets fitted into dispersion tubes. These tubelets extend from the center of the tube, where the steam is driest, through the tube wall, to the duct airstream. In essence, the tubelets provide a temperature-neutral exit tunnel for steam, allowing steam to cross over lower-temperature metal without condensing or dripping. Each tubelet contains a calibrated orifice sized for steam capacity. These tubelets are a DRI-STEEM exclusive, and are essential for drip-free steam dispersion.

### Condensate drains away

Some condensation is inevitable in steam dispersion, but through careful design, condensate can be controlled and directed away from where it can cause problems.

For example, the Ultra-sorb dispersion panel has a unique double-header design that uses gravity to remove condensate. Steam enters the supply header, exits through the tubelets, and condensate drains out the return header. In the Rapid-sorb dispersion unit, steam enters one end of a single bottom header with velocities carefully managed so that condensate is not pushed out into the air along with the steam; it drains out at the opposite end of the header.

### Reduce condensate, wasted energy with high-efficiency tubes

To significantly reduce condensate and wasted energy, use DRI-STEEM's high-efficiency tubes, which reduce dispersion-generated condensate and wasted energy by up to 85%. See *High-efficiency Tube option* on page 22.

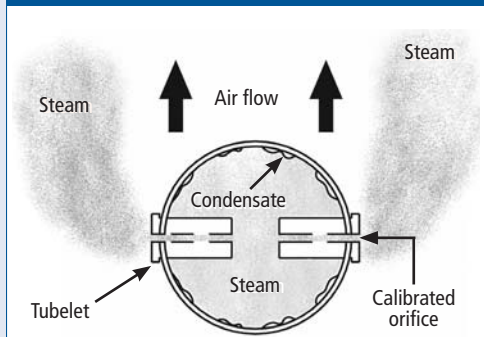
For more about dispersion, see Pages 22 – 31.

**Figure 21-1:**  
DRI-STEEM dispersion tubes



DRI-STEEM's dispersion tubes are fitted with one or two rows of closely-spaced thermal-resin tubelets to evenly disperse steam across the airstream.

**Figure 21-2:**  
DRI-STEEM tubelets

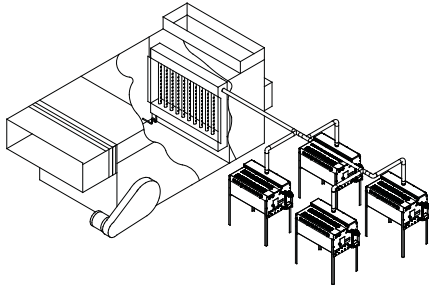


DRI-STEEM's unique tubelets extend into the center of the tube so only the driest steam is discharged into the air.

OM-150a

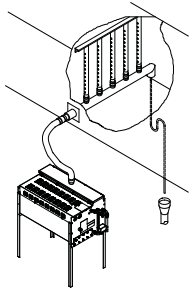
## Vaporstream steam dispersion options

**Figure 22-1:  
Ultra-sorb dispersion**



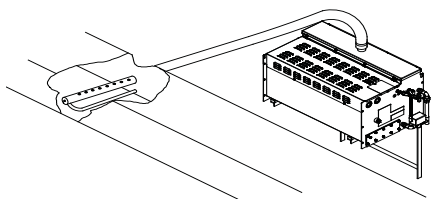
VLC-OM-13

**Figure 22-2:  
Rapid-sorb dispersion**



VLC-OM-14

**Figure 22-3:  
Single or multiple tube dispersion**



VLC-OM-15

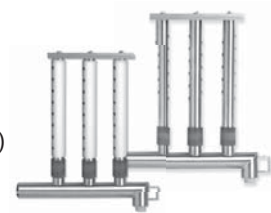
### Ultra-sorb®

- Double-header design
- Shortest non-wetting distance; install within inches of upstream dampers, coils, or elbows without dripping
- Steam capacity up to 1,850 lbs/hr (839 kg/h)
- Factory assembled for easy installation
- High-efficiency tube option



### Rapid-sorb®

- Single-header design
- Short non-wetting distance
- Steam capacity up to 800 lbs/hr (363 kg/h)
- Assembled on-site
- High-efficiency tube option



### Single or multiple tubes

- Horizontal or vertical airflow
- Available with or without condensate drain
- Steam capacity up to 85 lbs/hr (39 kg/h)



### High-efficiency Tube option

- Up to 85% reduction in wasted energy, airstream heat gain, and condensate production
- PVDF insulation is plenum-approved for in-duct installation
- Will not absorb water or support microbial growth; has a closed-cell structure
- Available on Ultra-sorb and Rapid-sorb

mc\_042710\_1345-NA



**Ultra-sorb panel  
with high-efficiency tubes**

## Vaporstream steam dispersion options

### Space Distribution Units (SDUs)

- For remotely dispersing steam into large open spaces
- Designed for use in finished spaces
- Useful where there are no air ducts
- SDU-E: external absorption at capacities up to 102 lbs/hr (46.3 kg/h)
- SDU-I: internal absorption at capacities up to 30 lbs/hr (13.6 kg/h)

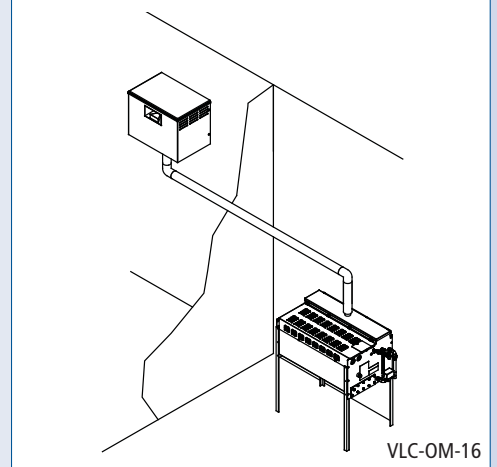


### Area-type™

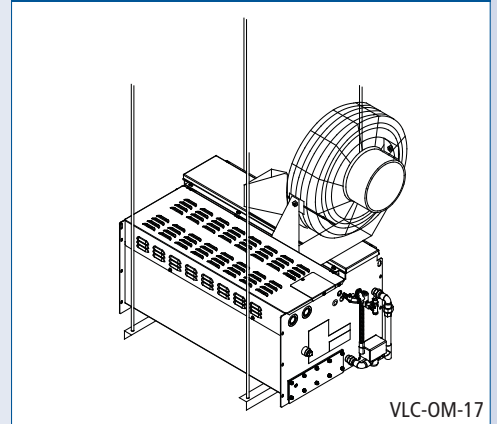
- Disperses steam in large open spaces
- Use where there are no air-handling ducts
- Steam is dispersed quietly without introducing water droplets into the air



**Figure 23-1:**  
Space Distribution Unit (SDU) dispersion



**Figure 23-2:**  
Area-type dispersion



## Calculating non-wetting distances

### Guaranteed absorption

- Cataloged and guaranteed steam absorption distances
- Unique tubelets in dispersion tubes eliminate condensate drips
- Published absorption tables for sizing and selecting the correct dispersion option
- Dri-calc® software available for system selection and absorption distance calculations

### Notes:

- Final equipment selection should account for condensate loss. See the *DRI-STEEM Design Guide* for steam loss tables.
- Dispersion assembly should accommodate maximum output capacity of humidifier.

### Sample exercise

Read through this exercise to learn more about specifying a dispersion unit based on non-wetting distance. Assume you have chosen to use Ultra-sorb units because you want pre-assembled panels.

Assume the entering air is 20% RH, and the leaving air needs to be 70% RH. Design for a non-wetting distance of 24" (610 mm) maximum.

### Solution

Refer to Figure 25-1. Find 20% entering RH. Proceed vertically until you intersect the 70% leaving RH line. Draw a line horizontally from that point to the right to see that for 24" (610 mm) of non-wetting distance, 6" (150 mm) tube spacing would be the closest match.

### Verify capacity

From Table 25-1, note that for 6" (150 mm) spacing, maximum capacity is 18 lbs/hr/ft<sup>2</sup> (88 kg/h/m<sup>2</sup>). Multiply this value by the active face area of the Ultra-sorb to determine if the unit will produce adequate output capacity. If the capacity is inadequate, go to the next smaller tube spacing.

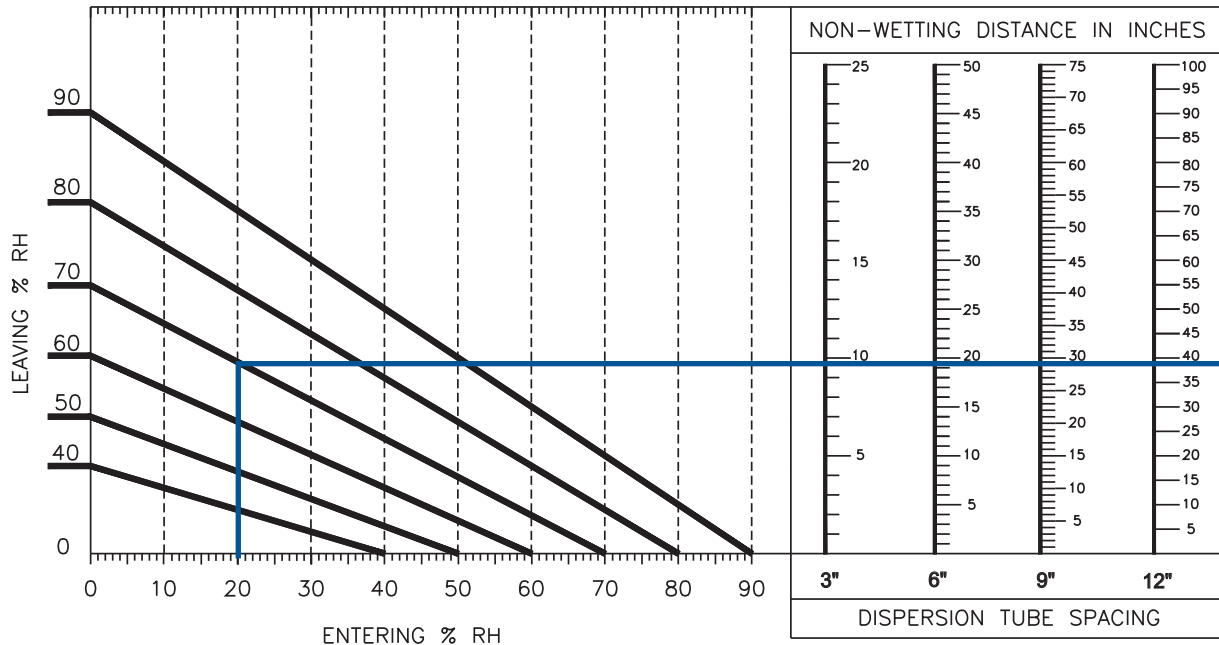
### Steam absorption considerations

1. Non-wetting distance is the dimension downstream from the leaving side of the steam dispersion assembly to the point where wetting will not occur, although wisps of steam may be present. Solid objects at duct air temperature, such as coils, dampers, fans, etc., downstream of this dimension will remain dry.
2. **CAUTION!** Non-wetting distances described in this catalog do not apply when installing a steam dispersion assembly upstream of filter media. If you need to install a steam dispersion assembly upstream of filter media, consult your representative or DRI-STEEM directly for special recommendations.
3. Note that the rise ( $\Delta$ ) in RH (the difference between entering and leaving RH) has a direct bearing on the non-wetting distance. As the rise increases, more vapor needs to be dispersed into the air, and thus the non-wetting distance increases.
4. Uneven airflow over the cross-section of a dispersion assembly can result in nonuniform mixing of steam with air which, in turn, will adversely affect the non-wetting distance.

mc\_042710\_0850

# Ultra-sorb dispersion

**Figure 25-1:  
Ultra-sorb non-wetting distances**



**Note:**

The above data apply to all air velocities up to 1,500 fpm (7.6 m/s), and are based on air leaving the zone of humidification at conditions of 55 °F (13 °C) and the stated % RH. The blue lines in the graph refer to the sample exercise described on Page 24.

mc\_042710\_0900

**Table 25-1:  
Ultra-sorb tube spacing and capacity**

Tube spacing		Maximum capacity	
inches	mm	lbs/hr/ft <sup>2</sup>	kg/h/m <sup>2</sup>
3	75	36	175
6	150	18	88
9	225	12	59
12	300	9	44

**Note:**

The above steam flow capacity data are based on pounds (kg) of steam per hour per square foot (meter) of face area, exclusive of headers, at various tube spacings.

mc\_042710\_0905

## Ultra-sorb dimensions

### Ultra-sorb LV

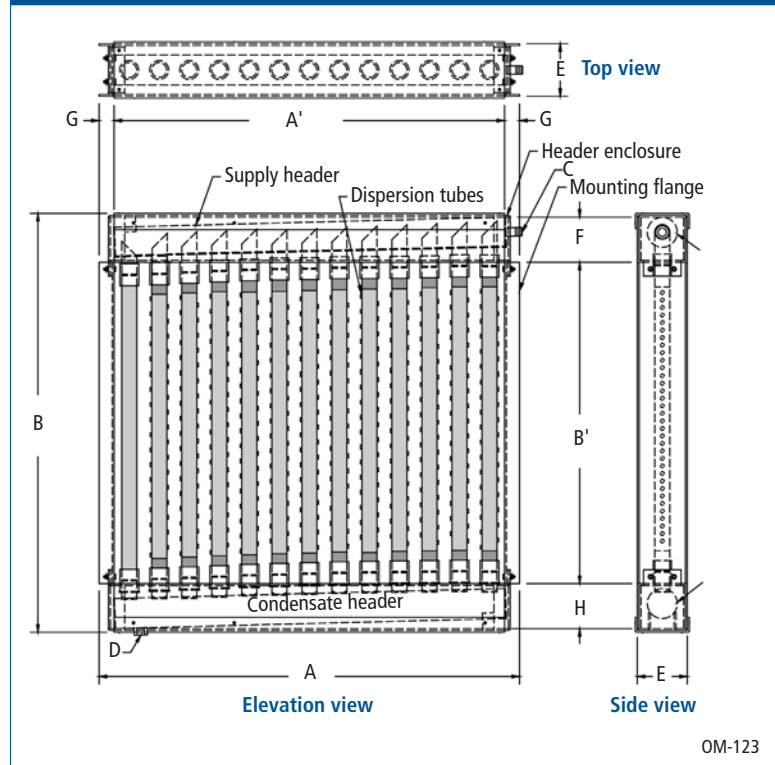
- Vertical dispersion tubes
- Suitable for AHUs or ductwork
- Use when duct height is greater than duct width
- May use with pressurized or nonpressurized steam (horizontal airflow only)

For Ultra-sorb Model LH (horizontal tubes), see the *Ultra-sorb Steam Dispersion Panels Product Catalog* (available at [www.dristeem.com](http://www.dristeem.com)).

**Table 26-1:**  
Nonpressurized steam header capacities

Header capacity		Header diameter	
lbs/hr	kg/h	inches	DN
300	135	3	80
600	270	4	100
1100	500	5	125
1850	820	6	150

**Figure 26-1:**  
Ultra-sorb LV dimensions



OM-123

**Table 26-2:**  
Ultra-sorb LV dimensions

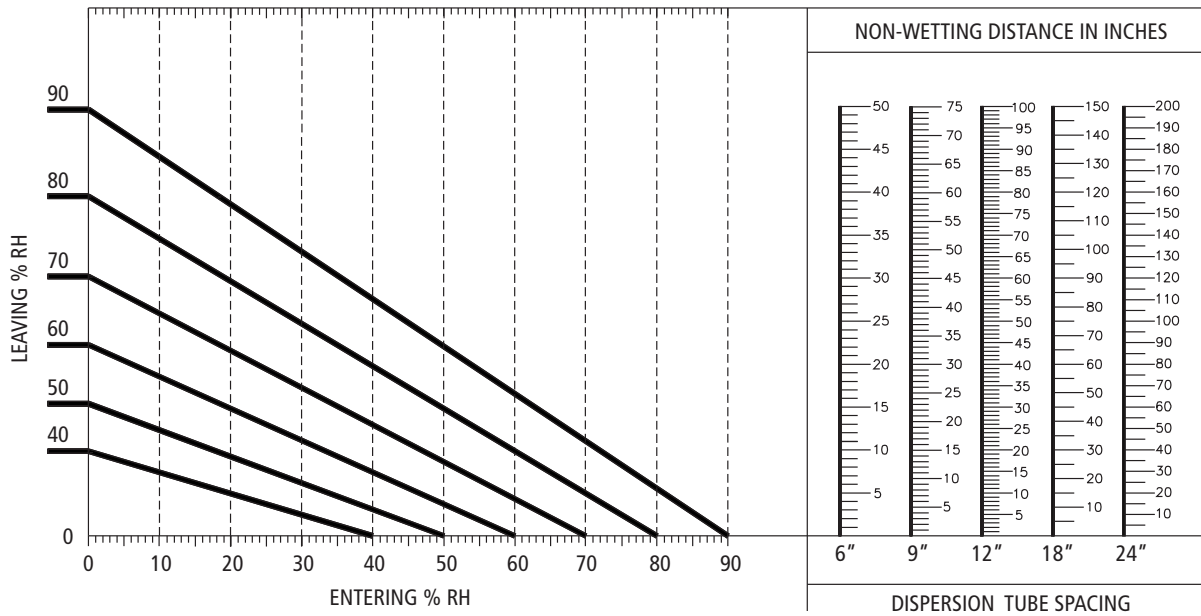
Dimension	Inches (mm)
A Overall width	15" (380) min, 147" (3735) max, in 1" (25) increments
A' Face width	12" (305) min, 144" (3660) max, in 1" (25) increments
B Overall height	21" (530) min, 156" (3960) max, in 1" (25) increments Panels with overall height more than 98" (2490 mm) are shipped unassembled.
B' Face height	12" (305) min, 144" (3660) max, in 1" (25) increments
C Steam inlet diameter	Determined by maximum steam capacity
D Condensate drain	¾" pipe thread (DN20)
E Header enclosure (front to back)	For 3" (DN80) and 4" (DN100) headers, E = 5" (127); for 5" (DN125) header, E = 6" (152); for 6" (DN150) header, E = 7" (178)
F Header enclosure (top to bottom)	For 3" (DN80) header F = 4.5" (114); for 4" (DN100) header, F = 5.5" (140); for 5" (DN125) header, F = 6.5" (165); for 6" (DN150) header F = 7.5" (191)
G Flange	1.5" (38)
H Condensate header enclosure	4.5" (114)

**Note:** Header dimensions are determined by capacity. See Table 26-1.

mc\_050808\_1215

# Rapid-sorb dispersion

**Figure 27-1:  
Rapid-sorb non-wetting distances**



**Note:**

The above data apply to all air velocities up to 1,500 fpm (7.6 m/s) and are based on air leaving the zone of humidification at 55 °F (13 °C) and the stated % RH.

**Table 27-1:  
Rapid-sorb header capacities**

Header capacity		Header diameter	
lbs/hr	kg/h	inches	DN
≤250	≤113	2	50
251-500	114-227	3	80
501-800	228-363	4	100

**Table 27-2:  
Rapid-sorb dispersion tube capacities\***

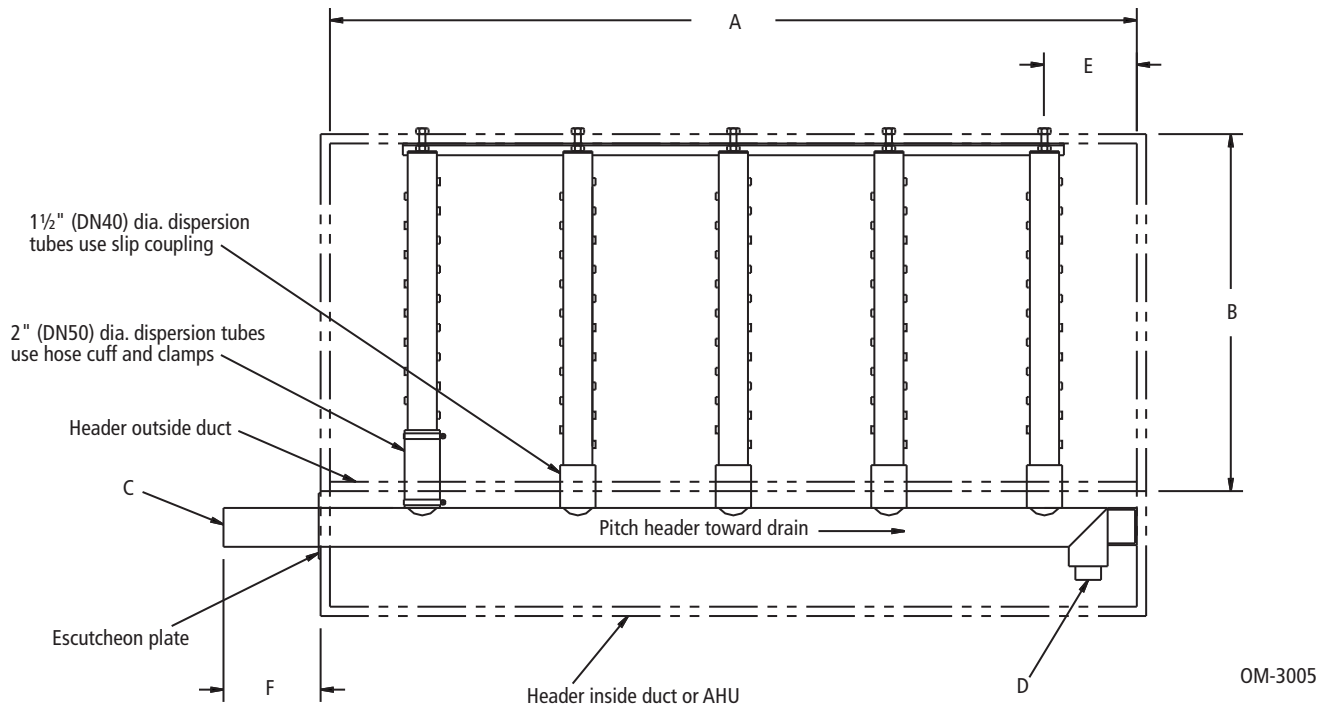
Tube capacity		Tube diameter	
lbs/hr	kg/h	inches	DN
≤35	≤16	1½	40
36-70	17-32	2	50

\* If duct height is <15" (381 mm), tube quantities may need to increase to compensate for reduced capacity of short tubes. Consult DRI-STEEM or see Dri-calc for the correct calculation.

mc\_042710\_1410

# Rapid-sorb dimensions

**Figure 28-1:  
Rapid-sorb dimensions**



**Note:**  
Add water seal to condensate drain as shown in the Dri-calc Installation Guides or the humidifier's Installation, Operation, and Maintenance manual.

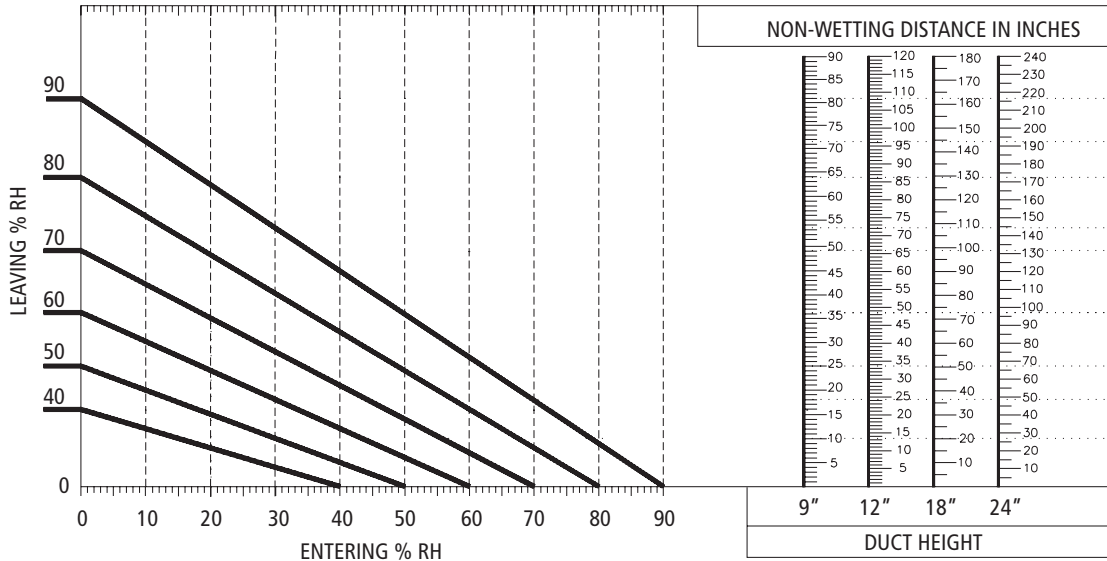
**Table 28-1:  
Rapid-sorb dimensions**

Dimension	Description	Inches (mm)
A	Face width	12" (305) minimum to 120" (3048) maximum in 1" (25) increments
B	Face height	12" (305) minimum to 120" (3048) maximum in 1" (25) increments
C	Steam inlet	Determined by humidifier maximum capacity
D	Condensate drain	¾" pipe thread (DN20)
E	Distance from tube center to inside of duct or AHU wall	4.5" (114) minimum
F	Distance from outside of duct or AHU wall to end of Rapid-sorb leader	4.5" (114) minimum

**Note:**  
All Rapid-sorb units are custom-sized and field-assembled to fit the duct or air handler. Consult DRI-STEEM for sizes larger or smaller than those listed above.

# Single dispersion tube

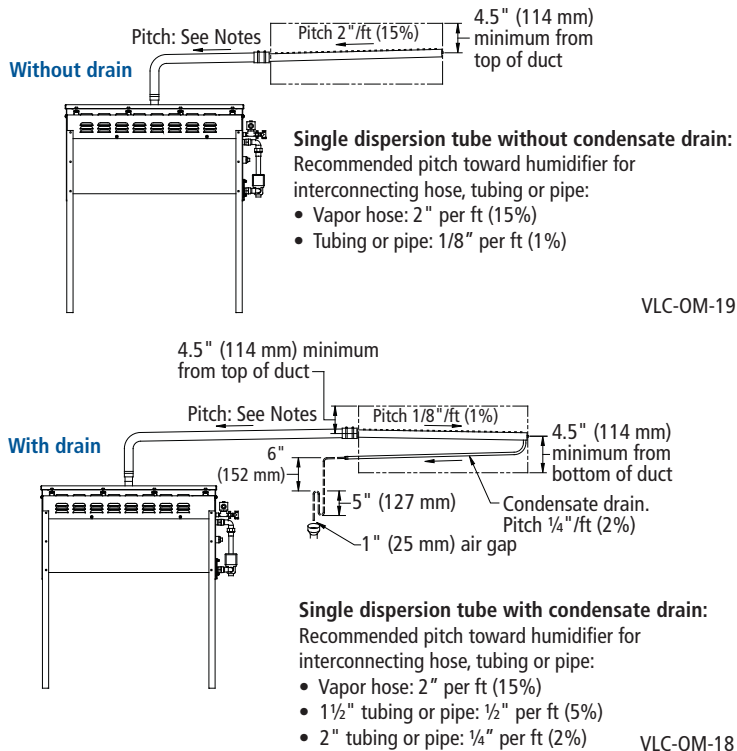
**Figure 29-1:**  
Single dispersion tube non-wetting distances



**Note:**  
The above data apply to all air velocities up to 1,500 fpm (7.6 m/s) and is based on air leaving the zone of humidification at 55 °F (13 °C) and the stated % RH.

mc\_042710\_1417

**Figure 29-2:**  
Single dispersion tube without and with condensate drain



**Table 29-1:**  
Single dispersion tube capacities

Tube size		Capacity			
		Without drain		With drain	
inches	DN	lbs/hr	kg/h	lbs/hr	kg/h
1 1/2	40	28.4	13	56.8	25.8
2	50	56.8	25.8	85.2	38.6

mc\_042710\_1416

## SDU-E and SDU-I dispersion

**Table 30-1:  
SDU-E minimum nonwetting distances**

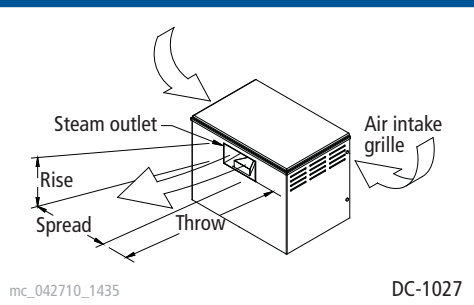
kW	Maximum steam capacity		40% RH @ 70 °F (21 °C)						50% RH @ 70 °F (21 °C)						60% RH @ 70 °F (21 °C)					
			Rise		Spread		Throw		Rise		Spread		Throw		Rise		Spread		Throw	
	lbs/hr	kg/h	ft	m	ft	m	ft	m	ft	m	ft	m	ft	m	ft	m	ft	m	ft	m
2	6	2.7	1.0	0.3	1.0	0.3	5.0	1.5	1.5	0.5	1.5	0.5	6.5	2.0	2.5	0.8	2.5	0.8	7.5	2.3
4	12	5.4	1.0	0.3	1.0	0.3	5.0	1.5	1.5	0.5	1.5	0.5	6.5	2.0	2.5	0.8	2.5	0.8	7.5	2.3
6	18	8.2	1.0	0.3	1.0	0.3	5.0	1.5	1.5	0.5	1.5	0.5	6.5	2.0	2.5	0.8	2.5	0.8	7.5	2.3
8	24	10.9	1.0	0.3	1.0	0.3	5.5	1.7	1.5	0.5	1.5	0.5	6.5	2.0	2.5	0.8	2.5	0.8	7.5	2.3
10	30	13.6	1.5	0.5	1.5	0.5	6.0	1.8	2.0	0.6	2.0	0.6	7.0	2.1	3.0	1.0	3.0	1.0	8.0	2.5
12	36	16.3	1.5	0.5	1.5	0.5	6.0	1.8	2.0	0.6	2.0	0.6	7.0	2.1	3.0	1.0	3.0	1.0	8.0	2.5
14	42	19.1	2.0	0.6	2.0	0.6	7.0	2.1	2.0	0.6	2.0	0.6	7.0	2.1	3.0	1.0	3.0	1.0	9.0	2.7
16	48	21.8	2.0	0.6	2.0	0.6	7.0	2.1	2.0	0.6	2.0	0.6	7.0	2.1	3.0	1.0	3.0	1.0	9.0	2.7
21	63	28.6	2.0	0.6	2.0	0.6	7.5	2.3	2.5	0.8	2.5	0.8	10.0	3.0	3.0	1.0	3.0	1.0	12.0	3.7
25	75	34.0	2.0	0.6	2.0	0.6	8.0	2.5	2.5	0.8	2.5	0.8	10.5	3.2	3.5	1.1	3.5	1.1	12.5	3.8
30	90	40.9	2.0	0.6	2.0	0.6	8.0	2.5	2.5	0.8	2.5	0.8	10.5	3.2	3.5	1.1	3.5	1.1	12.5	3.8
34	102	46.3	2.0	0.6	2.0	0.6	8.0	2.5	2.5	0.8	2.5	0.8	10.5	3.2	3.5	1.1	3.5	1.1	12.5	3.8

**Notes:**

- Surfaces or objects directly in the path of vapor discharge may cause condensation and dripping.
- To avoid steam impingement on surrounding areas, observe the minimum nonwetting dimensions in this table.
- Rise: The minimum nonwetting height above the steam outlet of the SDU-E.
- Spread: The minimum nonwetting width from the steam outlet of the SDU-E.
- Throw: The minimum nonwetting horizontal distance from the steam outlet of the SDU-E.

mc\_042710\_1300

**Figure 30-1:  
SDU-E rise, spread and throw**



mc\_042710\_1435

**Table 30-2:  
Space Distribution Unit specifications\*\***

SDU model	Maximum capacity		Shipping weight		Amps at 120V (50/60 Hz)	Horsepower	cfm	m³/s	dB*
	lbs/hr	kg/h	lbs	kg					
SDU-E	102	46.3	61	28	2.07	1/8	545	0.26	64
SDU-I	30	13.6	68	31	3.20	1/5	760	0.36	58

\* Measurement taken 6.5' (2 m) in front of SDU cabinet.

\*\* For visible vapor to be absorbed completely within the SDU-I unit before being discharged as humidified air, room air must be 45% RH or less. Trying to maintain greater than 45% RH will cause visible vapor and potential for moisture collection on the discharge grille.

mc\_042710\_1440

# Area-type dispersion

**Table 31-1:**  
Area-type (evaporative steam) minimum non-wetting distances\*

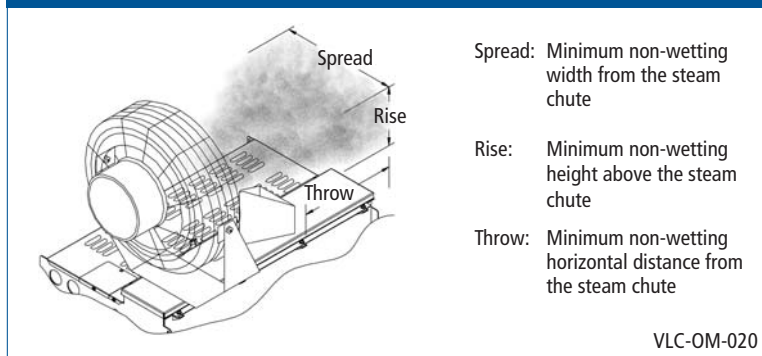
Maximum steam capacity		60 °F (16 °C)																	
		30% RH						40% RH						50% RH					
		Rise		Spread		Throw		Rise		Spread		Throw		Rise		Spread		Throw	
lbs/hr	kg/h	ft	m	ft	m	ft	m	ft	m	ft	m	ft	m	ft	m	ft	m	ft	m
50	20	1.0	0.3	2.0	0.6	6.0	1.8	1.0	0.3	2.0	0.6	6.0	1.8	1.0	0.3	2.5	0.8	6.0	1.8
75	34	3.0	0.9	3.0	0.9	8.0	2.4	3.0	0.9	3.0	0.9	8.0	2.4	3.0	0.9	4.0	1.2	8.0	2.4
100	45	4.0	1.2	4.0	1.2	10.0	3.1	4.0	1.2	4.0	1.2	10.0	3.1	4.0	1.2	5.0	1.5	10.0	3.1
150	68	6.0	1.8	5.0	1.5	12.0	3.7	6.0	1.8	5.0	1.5	12.0	3.7	6.0	1.8	5.0	1.5	12.0	3.7
200	90	7.0	2.1	7.0	2.1	13.0	4.0	8.0	2.4	7.0	2.1	14.0	4.3	8.0	2.4	7.0	2.1	14.0	4.3
225	102	7.0	2.1	7.0	2.1	13.0	4.0	8.0	2.4	7.0	2.1	14.0	4.3	8.0	2.4	7.0	2.1	14.0	4.3
250	110	8.0	2.4	8.0	2.4	15.0	4.6	9.0	2.7	9.0	2.7	16.0	4.9	9.0	2.7	9.0	2.7	16.0	4.9
285	130	9.0	2.7	9.0	2.7	17.0	5.2	10.0	3.1	10.0	3.1	18.0	5.5	10.0	3.1	10.0	3.1	18.0	5.5
300	136	9.0	2.7	9.0	2.7	17.0	5.2	10.0	3.1	10.0	3.1	18.0	5.5	10.0	3.1	10.0	3.1	18.0	5.5

Maximum steam capacity		70 °F (16 °C)																	
		30% RH						40% RH						50% RH					
		Rise		Spread		Throw		Rise		Spread		Throw		Rise		Spread		Throw	
lbs/hr	kg/h	ft	m	ft	m	ft	m	ft	m	ft	m	ft	m	ft	m	ft	m	ft	m
50	20	1.0	0.3	1.5	0.5	4.0	1.2	1.0	0.3	2.0	0.6	4.0	1.2	1.0	0.3	2.0	0.6	4.0	1.2
75	34	2.0	0.6	2.0	0.6	6.0	1.8	2.0	0.6	2.5	0.8	6.0	1.8	2.0	0.6	2.5	0.8	6.0	1.8
100	45	3.0	0.9	3.0	0.9	8.0	2.4	3.0	0.9	3.0	0.9	8.0	2.4	3.0	0.9	3.0	0.9	8.0	2.4
150	68	4.0	1.2	4.0	1.2	10.0	3.1	4.0	1.2	4.0	1.2	11.0	3.4	4.0	1.2	4.0	1.2	11.0	3.4
200	90	5.0	1.5	5.0	1.5	11.0	3.4	5.0	1.5	5.0	1.5	12.0	3.7	5.0	1.5	5.0	1.5	12.0	3.7
225	102	5.0	1.5	5.0	1.5	11.0	3.4	5.0	1.5	5.0	1.5	12.0	3.7	5.0	1.5	5.0	1.5	12.0	3.7
250	110	6.0	1.8	6.0	1.8	12.0	3.7	6.0	1.8	6.0	1.8	13.0	4.0	6.0	1.8	6.0	1.8	14.0	4.3
285	130	7.0	2.1	7.0	2.1	14.0	4.3	7.0	2.1	7.0	2.1	15.0	4.6	7.0	2.1	7.0	2.1	16.0	4.9
300	136	7.0	2.1	7.0	2.1	14.0	4.3	7.0	2.1	7.0	2.1	15.0	4.6	7.0	2.1	7.0	2.1	16.0	4.9

\* With fan on high speed

**Figure 31-1:**  
Area-type rise, spread, throw



mc\_030210\_0940

**Table 31-2:**  
Area-type electric fan specifications\*

Motor	120 V, 50/60 Hz
Blade diameter	18" (457 mm)
Speeds	3
Control	Rotary switch
cfm (high speed)	3190
m <sup>3</sup> /s (high speed)	1.51
rpm (high speed)	1500
Amps (high speed)	1.52

## Conserving resources through better performance

### Expect quality from the industry leader

For more than 45 years, DRI-STEEM has been leading the industry with creative and reliable humidification solutions. Our focus on quality is evident in the construction of the Vaporstream humidifier, which features cleanable, stainless steel construction. DRI-STEEM also leads the industry with a Two-year Limited Warranty and optional extended warranty.

### For more information

[www.dristeem.com](http://www.dristeem.com)  
[sales@dristeem.com](mailto:sales@dristeem.com)

For the most recent production information visit our web site:  
[www.dristeem.com](http://www.dristeem.com)

### DRI-STEEM Corporation

An ISO 9001:2000 certified company

U.S. Headquarters:  
14949 Technology Drive  
Eden Prairie, MN 55344  
800-328-4447 or 952-949-2415  
952-229-3200 (fax)

European office:  
Marc Briers  
Grote Hellekensstraat 54 b  
B-3520 Zonhoven  
Belgium  
+3211823595 (voice)  
+3211817948 (fax)  
E-mail: [marc.briers@dristeem.com](mailto:marc.briers@dristeem.com)

Continuous product improvement is a policy of DRI-STEEM Corporation; therefore, product features and specifications are subject to change without notice.

DRI-STEEM, Dri-calc, Rapid-sorb, Ultra-sorb, Vapor-logic, and Vaporstream are registered trademarks of DRI-STEEM Corporation and are filed for trademark registration in Canada and the European community.

Area-type and Drane-kooler are trademarks of DRI-STEEM Corporation.

Product and corporate names used in this document may be trademarks or registered trademarks. They are used for explanation only without intent to infringe.

Clean room cover image courtesy of Rakon Limited.

© 2011 DRI-STEEM Corporation



Form No. VLC-CAT-0311



DRI-STEEM conserves resources by designing humidification systems that optimize performance. Systems that perform well save energy and water and, ultimately, cost less to operate and maintain.

### Save energy

For applications requiring short absorption, high-efficiency dispersion tubes reduce wasted energy up to 85% by significantly reducing airstream heat gain and condensate production. Available for new and retrofit Ultra-sorb® and Rapid-sorb® steam dispersion panels.

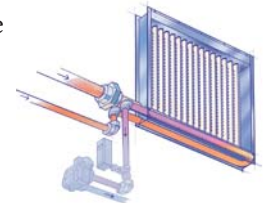


For warm, dry applications, DRI-STEEM's High-Pressure Atomizing System disperses unheated micro-fine water particles into airstreams or open spaces. As atomized water droplets evaporate, air temperature drops, reducing the cooling load. This provides significant energy savings when humidifying and cooling simultaneously.



### Save water

Ultra-sorb Model XV eliminates water waste and reduces airstream heat gain, energy costs, and boiler chemical use. Available for STS® steam-to-steam humidifiers and all pressurized steam applications.



### Optimize performance

DRI-STEEM's most advanced controller, Vapor-logic®4 continuously monitors space conditions to align humidifier output with demand. The result is accurate, responsive control.



### Your DRI-STEEM representative is: