

DRISTEEM[®]
The humidification experts



Ultra-sorb Model LV



Ultra-sorb Model LH



Ultra-sorb Model XV

- *Guaranteed short non-wetting distances*
- *Reduce wasted energy and condensate up to 85%*
- *Lowest installation cost*

Ultra-sorb[®]
Steam Dispersion Panels
PRODUCT CATALOG



All Ultra-sorb models feature:



Hospitals



Institutions



Technology

Guaranteed, short non-wetting distances

Install within inches of downstream devices.

Rapid, drip-free steam absorption means steam does not condense on downstream devices.

Efficient by design

Reduce wasted energy and condensate up to 85%.

High-Efficiency Insulated Tubes significantly reduce airstream heat gain and condensate production.

(Standard on Model XV; optional on Models LV and LH.)

Higher capacities per tube increase efficiency, reduce cost.

Insulated dispersion tubes produce less condensate and, therefore, have more steam available for humidification, increasing the capacity of each tube. As a result, fewer tubes may be required to meet application requirements, further lowering condensate production and heat gain while reducing resource consumption and cost.

No steam jackets; no unnecessary heat gain.

When there is no call for humidity, Ultra-sorb panels are at duct temperature while conventional jacketed steam injection systems stay hot and continue to add heat to the airstream.

Lowest installation cost

Factory assembly eases installation.

Panels ship preassembled and install quickly with easy mounting, steam, and condensate connections.

Contents

Ultra-sorb overview Pages 1-3

Models comparison..... 4-5

Model XV

Operation and components 6-9

Dimensions, capacity 10

Location..... 18-19

Mounting..... 11

Connections..... 12-13

Models LV and LH

Operation and components 14-15

Dimensions, capacity 16-17

Location..... 18-19

Mounting..... 20-21

Connections..... 22-23

More benefits, by model:

Model XV: Highest performance

Integral condensate management.

An industry first for pressurized steam, Ultra-sorb Model XV vaporizes dispersion-generated condensate and returns pressurized condensate to the boiler without additional pumps, valves, vents, or controls.

Most efficient dispersion.

Zero water waste.

All condensate returns to the boiler while still hot, saving energy, water, and boiler chemicals.

Lowest heat gain.

High-Efficiency Insulated Tubes and an insulated steam delivery header reduce airstream heat gain by up to 85%.

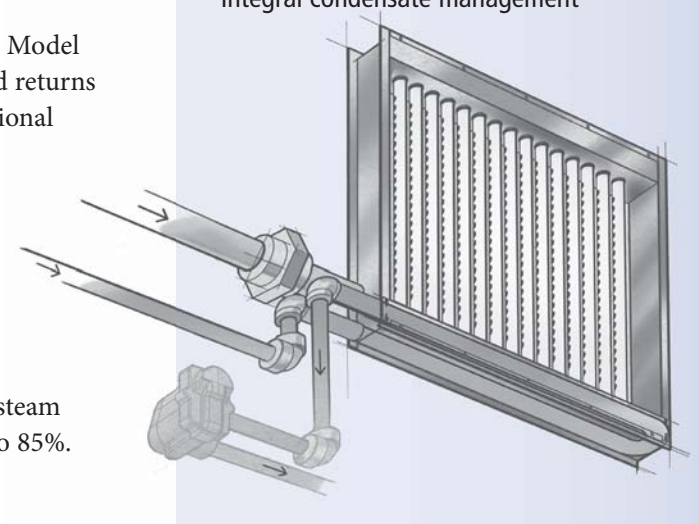

Ultra-sorb Model XV

Integral condensate management

Models LV and LH: Most versatile

Disperse pressurized or nonpressurized steam.

Models LV and LH disperse steam generated by pressurized steam boilers or by nonpressurized steam generators such as DRI-STEEM's GTS®, STS, Vaporstream®, Vapormist®, and XT humidifiers.

Wide capacity range and options

- Steam capacity up to 4,000 lbs/hr (1815 kg/h)
- High-Efficiency Insulated Tubes option
- 316 stainless steel construction option

Ultra-sorb Model LV

Vertical tubes



Ultra-sorb Model LH

Horizontal tubes



Ultra-sorb models comparison

Table 4-1: Ultra-sorb models comparison			
	Model XV Integral condensate management	Ultra-sorb Model LV Vertical tubes	Ultra-sorb Model LH Horizontal tubes
Steam source	Humidification steam inlet: Steam from boiler or STS humidifier Heat exchanger: Pressurized boiler steam	Pressurized boiler steam or nonpressurized steam	
Steam capacity	Per panel: Pressurized boiler steam: Up to 1978 lbs/hr (898 kg/h) One Ultra-sorb Model XV with STS: Up to 450 lbs/hr (204 kg/h) Per tube: 43 lbs/hr (19.5 kg/h)*	Per panel: Up to 4000 lbs/hr (1815 kg/h) Per tube: Insulated: 86 lbs/hr (39 kg/h)** Uninsulated: 80 lbs/hr (36 kg/h)**	Per panel: Up to 3268 lbs/hr (1482 kg/h) Per tube: Insulated: 86 lbs/hr (39 kg/h)*** Uninsulated: 80 lbs/hr (36 kg/h)***
Steam pressure	Heat exchanger: 5 to 50 psi (35 to 345 kPa) Humidification steam inlet: 5 to 50 psi, pressurized boiler; or atmospheric, STS humidifier	Up to 50 psi (345 kPa)	
Airflow	Horizontal	Horizontal	Horizontal (pressurized steam) Vertical (nonpressurized steam)
High-Efficiency Insulated Dispersion Tubes	Standard	Available option	
Header insulation	Header inside of enclosure is insulated	Header enclosure provides air gap insulation	
Condensate drain	Pressurized	Atmospheric	
Condensate lifting	Vaporizes dispersion tube-generated condensate in header; returns pressurized condensate to condensate return main	Available pump	
Airstream heat gain	Lowest	Low with High-Efficiency Insulated Tubes option	
Non-wetting distance	Shortest; performs to published Ultra-sorb non-wetting distance		
Face dimensions	12" x 12" up to 144" x 144" (305 x 305 to 3660 x 3660 mm)	12" x 12" up to 144" x 144" (305 x 305 to 3660 x 3660 mm)	12" x 12" up to 120" x 120" (305 x 305 to 3050 x 3050 mm)
Assembly	Pre-assembled (shipped unassembled by request or as larger dimensions require)		
Dispersion tube mounting	Spring-loaded tubes and frame	Slip couplings and frame	
Steam / drain connections	Inlet: Steam for humidification Inlet: Pressurized steam for heat exchanger Outlet: Pressurized condensate to return main Outlet: For optional header overflow (if no float switch)	Inlet: Steam for humidification Outlet: Condensate drain	
Airflow	Horizontal	Horizontal	Horizontal or vertical
Weight	For Ultra-sorb weights, see our free Dri-calc sizing and selection software. Go to our Tools page at www.dristeem.com to order a free copy of Dri-calc.		
Piping connections	Same-side connections	Top or side steam inlet, opposite-side drain connection	Top or side steam inlet, 2 drain connections (one per header)
Optional 316 stainless steel construction, and stainless steel trap, valve, and strainer	No	Yes	
Notes: * Consult DRI-STEEM when face height dimension is less than 17" (432 mm). ** Consult DRI-STEEM when face height dimension is less than 26" (660 mm). *** Consult DRI-STEEM when face width dimension is less than 25" (635 mm).			

Ultra-sorb models comparison

**Table 5-1:
Condensate piping for Ultra-sorb steam dispersion panels**

	Model XV	Models LV and LH	
		Nonpressurized steam	Pressurized steam
P-trap water seal (see Figure 23-4)	n/a	Drop: 6" (150 mm) Seal: 5" (130 mm)	<u>Recommended:</u> Drop: 8" (205 mm) Seal: 10" (255 mm)
F&T trap (see Figures 12-1, 12-3, and 23-3)	Yes	No	<u>Alternate: *</u> Drop: 12" (305 mm) Drip: 4" (105 mm)
Inverted bucket trap, for lifting condensate to elevated condensate return main (see Figure 5-1)	Yes, with no additional pumps, valves, or controls	No	No
Stainless steel thermostatic trap	No	No	No
Condensate to open drain (see Figures 23-3 and 23-4)	n/a	Yes	Yes
Condensate return by condensate pump (see Figure 23-2)	n/a	Yes	Yes
Condensate return to humidifier by gravity	n/a	Yes	n/a
Condensate return to boiler via return line (see Figure 12-1 and 12-2)	Yes, with no additional pumps, valves, vents or controls	n/a	No

Note:

* Provide 18" (460 mm) vertical clearance for future P-trap substitution if required.

**Figure 5-1:
Lifting condensate with Ultra-sorb Model XV**

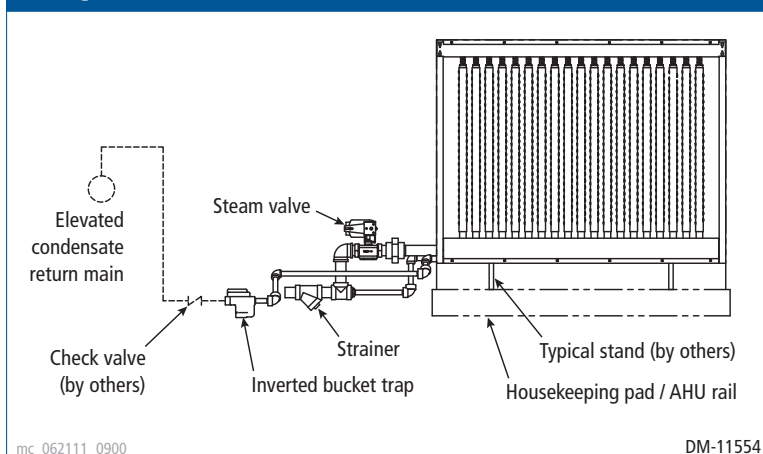

Ultra-sorb Model XV vaporizes dispersion-generated condensate and returns pressurized condensate to the boiler without additional pumps, valves, vents, or controls.

Model XV: Operation and components

Figure 6-2:
Model XV principle of operation



Ultra-sorb Model XV accepts humidification steam directly from a boiler or DRI-STEEM STS steam-to-steam humidifier, which transfers boiler steam energy (through a heat exchanger) to clean fill water to boil it into humidification steam.

Figure 6-1:
Model XV principle of operation

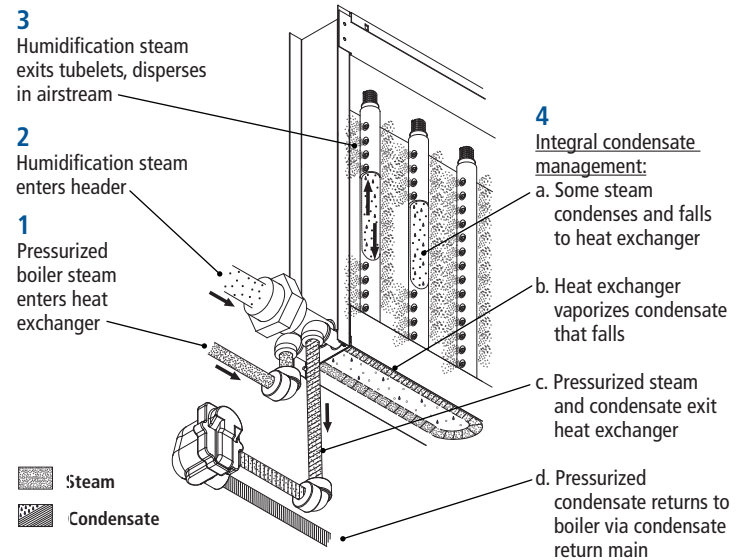

Principle of operation and components

1. Pressurized steam enters heat exchanger

Pressurized steam entry to the heat exchanger is controlled manually or by an on-off electric solenoid valve that admits steam to the heat exchanger when there is a call for humidity.

2. Humidification steam enters insulated header

Humidification steam entry is controlled by either an electric or pneumatic modulating valve, which admits pressurized steam directly to the header, or by the STS humidifier control system, which modulates steam output from the STS humidifier to meet humidification demand.

3. Humidification steam flows through High-Efficiency Insulated Dispersion Tubes

Humidification steam flows through the insulated header, up the High-Efficiency Insulated Tubes, and into the airstream. Dispersion tube insulation provides up to an 85% reduction in wasted energy by significantly reducing airstream heat gain and condensate production. See Pages 9 for more information.

4. Integral condensate management

The heat exchanger vaporizes dispersion-generated condensate, which creates condensate within the heat exchanger. This condensate returns to the boiler via the condensate return main with **no additional pumps, valves, vents, or controls.**

Model XV: Operation and components

Figure 7-1:
Ultra-sorb Model XV operating with pressurized humidification steam

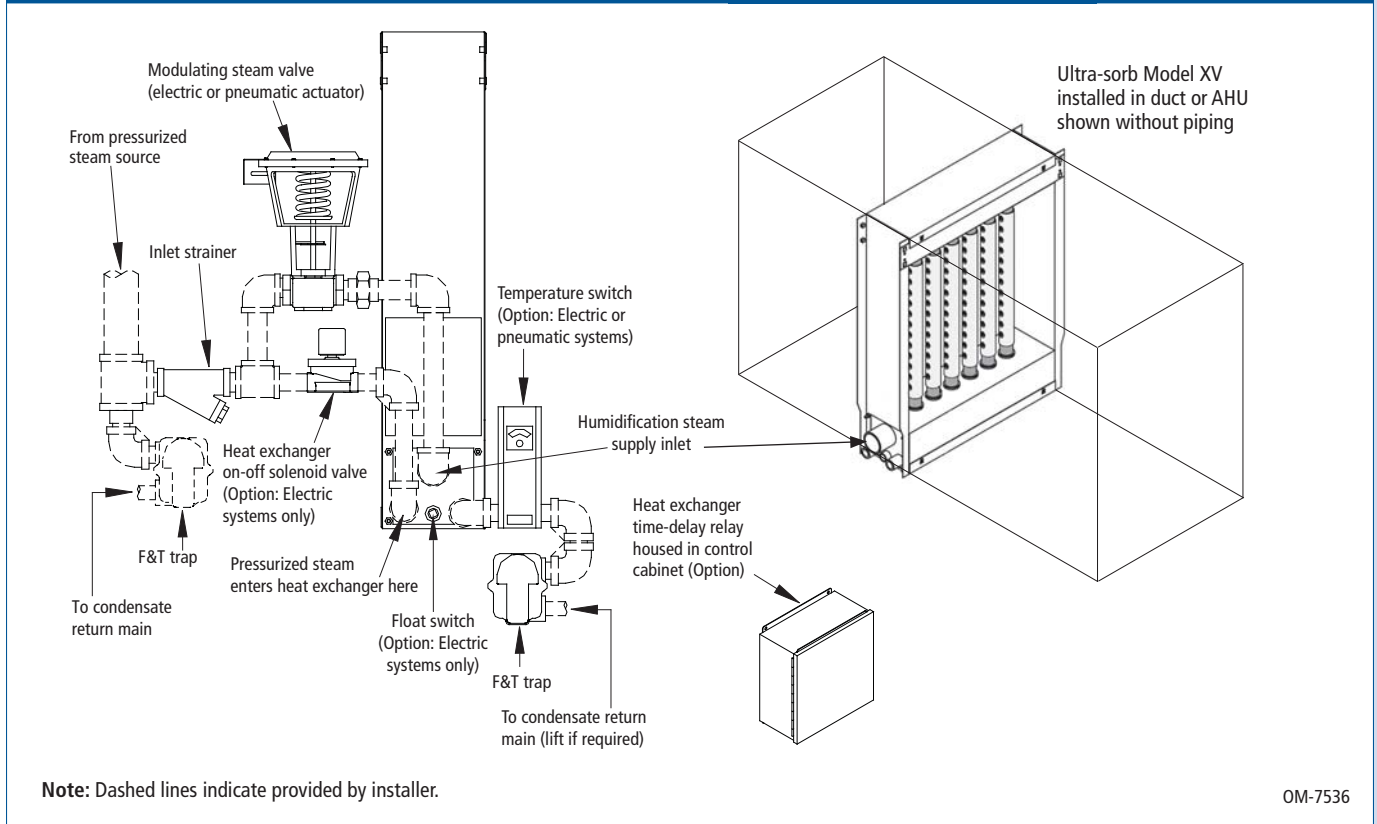
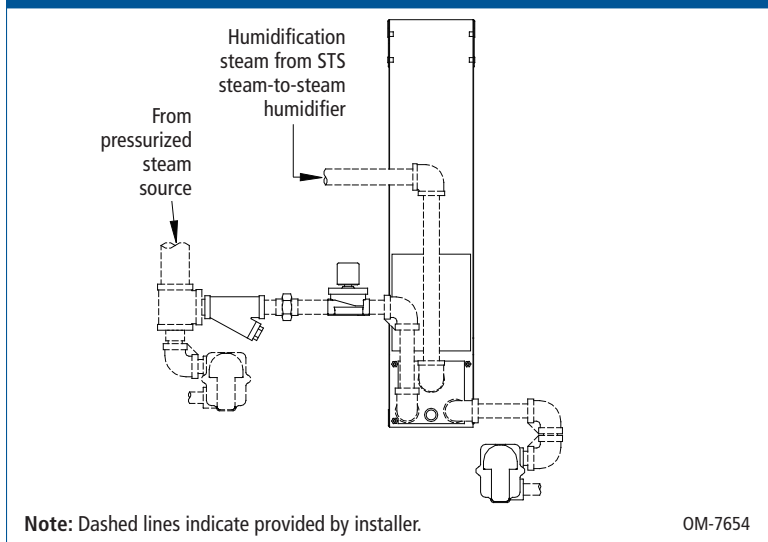

Figure 7-2:
Ultra-sorb Model XV with DRI-STEEM STS humidifier providing humidification steam



Model XV: Operation and components

Heat exchanger control options

Heat exchanger options are packaged and available for ordering as shown below.

Boiler steam only (no STS Humidifier):

- a. Heat exchanger solenoid valve, time delay relay, float switch (if electric valve), temperature switch (if pneumatic valve) and control cabinet
- b. Heat exchanger solenoid valve only
- c. Temperature switch, pneumatic
- d. Temperature switch, electric
- e. Redundant safety device (temperature switch); (requires a or b above and electric valve)

Boiler steam paired with an STS Humidifier:

- e. Control via STS Humidifier
- f. Temperature switch, pneumatic
- g. Temperature switch, electric

Principle of operation and components (see Figure 7-1)

5. Control safety options

In the unlikely event that excessive header condensate cools the heat exchanger while humidifying, a **temperature switch** (electric or pneumatic) opens. This signals the modulating steam valve or STS humidifier control system to stop humidification steam from entering the header and prevents further condensate production. After the header condensate evaporates, the switch closes, allowing humidification steam to flow when there is a call for humidity.

An **electric float switch** (with electric control valve only) opens in the unlikely event the humidification steam delivery header becomes flooded with condensate. The switch opening stops the delivery of humidification steam. After excess header condensate evaporates the float switch returns to its normally-closed position, allowing humidification steam to flow when there is a call for humidity.

Upon a drop in the call for humidity, the **time delay relay** keeps the heat exchanger valve open for 30 minutes (or as field set), allowing steam to flow through the heat exchanger and dry out the header. This prevents microbial growth during prolonged non-humidifying periods.

The **control cabinet**, which includes the time delay relay, is required when the solenoid and modulating valves are controlled by DRI-STEEM.

Model XV: Operation and components

High-Efficiency Insulated Dispersion Tubes

High-Efficiency Tubes are standard on Ultra-sorb Model XV and an available option for new or existing Ultra-sorb Models LV and LH.

The PVDF insulation on High-Efficiency Tubes provides the following benefits:

- **Reduce heat gain and condensate production by up to 85%** when using High-Efficiency Insulated Dispersion Tubes instead of uninsulated dispersion tubes, regardless of load or airstream temperature.
- **Save energy and water.** Every pound of condensate that does not drain from the dispersion assembly saves the Btus (about 1,000) required to boil it into steam.
- **Gain capacity.** Specify fewer tubes and smaller steam generators. With a higher percentage of generated steam meeting the humidification load, fewer dispersion tubes are needed and steam generators can be downsized in many cases.

Advanced insulation meets stringent requirements

PVDF is an advanced material commonly used in chemical, semiconductor, medical, defense, and aerospace industries and has the following characteristics:

- **Approved for use in plenums.** Flame spread/smoke developed values are 0/0, exceeding UL 723 (ASTM E84) requirement of 25/50.
- **Rated for high-temperature operation.** Rated for 300 °F (149 °C) continuous operation.
- **Will not absorb water or support microbial growth** due to its closed-cell construction
- **Virtually no airflow pressure drop.** PVDF insulation is only 1/8" (3.2 mm) thick.
- **Will not shift or slip on tubes.** Advanced manufacturing process ensures insulation attaches securely to tubes.
- **Odor free.** Virtually no measurable outgassing.
- **Resistant to UV light.**
- **Rugged and durable.** No particle erosion per ASTM C1071 erosion resistance test; does not contain fiberglass.

Figure 9-1:
Dispersion tube heat loss

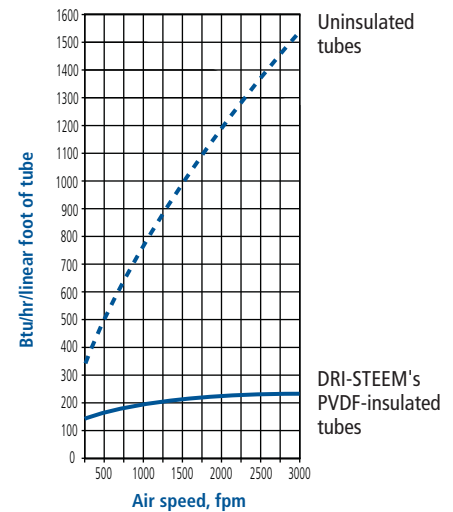

Notes:

- This graph illustrates dispersion tube heat loss vs. airspeed at 50 °F (10 °C) for a 3" (76 mm) o.c. tube bank, 1½" (DN40) dia. stainless steel tubes with 212 °F (100 °C) internal wall temperature
- Heat loss calculations based on the following references: Zhukauskas, A. 1987. *Convective Heat Transfer in Cross Flow*. In S. Kakac, R.K. Shah, and W. Ang, eds. *Handbook of Single-Phase Convective Heat Transfer*. New York: John Wiley & Sons, pp. 6.1-6.45.
- PVDF insulation on tube is 1/8" (3.2 mm) thick and has a thermal conductivity of 0.0185 Btu/hr-ft-F 0.0107 W/m•K.

Read our white paper

For details on the breakthrough performance of High-Efficiency Tubes, see our High-Efficiency Tubes Option white paper on the Literature page of our website: www.drsteem.com

Model XV: Dimensions, capacity

Table 10-1:
Ultra-sorb Model XV dimensions

Dimension	Inches (mm)
A Unit width	15" (380 mm) min, 147" (3735 mm) max, in 1" (25 mm) increments
A' Face width	12" (305 mm) min, 144" (3660 mm) max, in 1" (25 mm) increments
B Unit height*	21.75" (550 mm) min, 153.75" (3905 mm) max, in 1" (25 mm) increments
B' Face height	12" (305 mm) min, 144" (3660 mm) max, in 1" (25 mm) increments
C Frame depth	7.2" (183 mm)
D Frame enclosure	3.9" (99 mm)
E Header enclosure	5.85" (149 mm)
F Mounting flange	1.5" (38 mm)
G Humidification steam inlet (internal thread)	<ul style="list-style-type: none"> • 1" or 2" NPT (DN25 or DN50), determined by maximum steam capacity • 3" (DN80) flange, for humidification steam from STS humidifier only
H Pressurized steam inlet (internal thread)	3/4" NPT (DN20)
J Float switch, optional header overflow/access port (internal thread)	1/2" NPT (DN15)
K Pressurized condensate outlet (internal thread)	3/4" NPT (DN20)
L Overall width	<ul style="list-style-type: none"> • 1" (DN25) connection, same as dimension A; • 2" (DN50) connection, dimension A + 1" (dimension A + 25 mm) • 3" (DN80) flange, dimension A + 6.5" (dimension A + 165 mm)
Control cabinet	See Figure 10-2.

Note:

* Panels with unit height more than 120" (3048 mm) have two-piece side flanges and are shipped with brackets and panel fasteners for easy field assembly. Panels with unit height more than 98" (2490 mm) are shipped unassembled.

mc_091608_1500

Table 10-2:
Ultra-sorb Model XV tube capacity*

lbs/hr	kg/h
43	19.5

Note:

* If face height is <17" (432 mm), consult DRI-STEEM or see Dri-calc for the correct calculation.

Figure 10-1:
Ultra-sorb Model XV dimensions

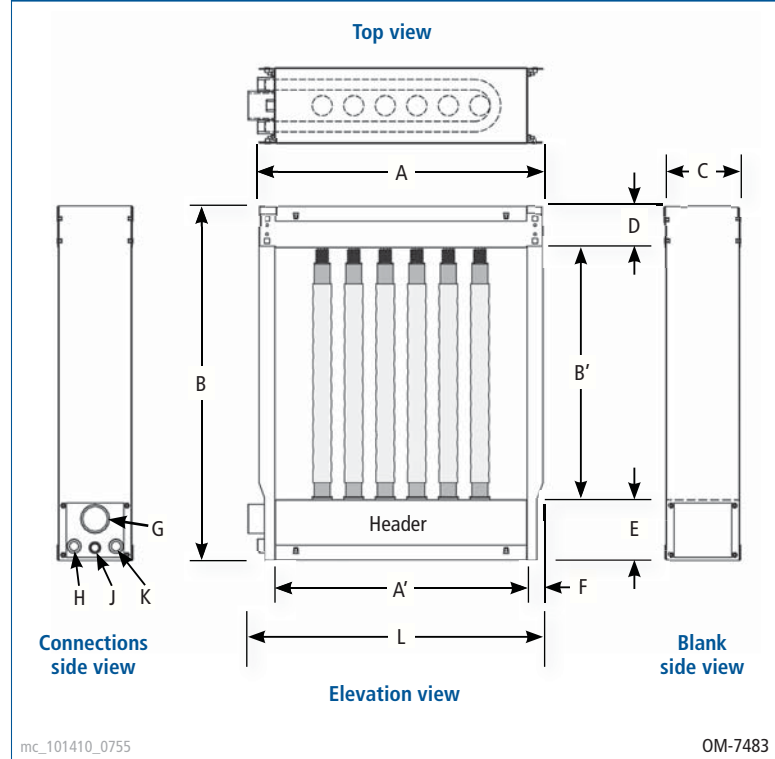
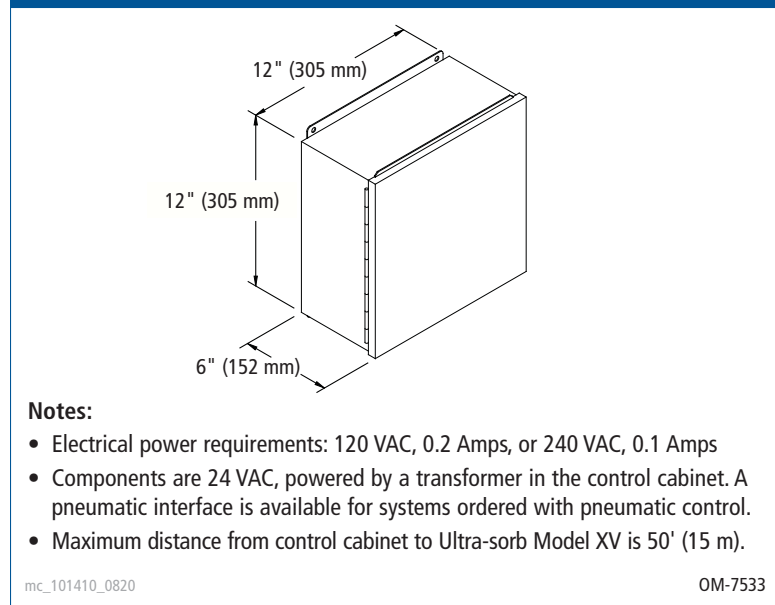

Figure 10-2:
Ultra-sorb Model XV control cabinet



Notes:

- Electrical power requirements: 120 VAC, 0.2 Amps, or 240 VAC, 0.1 Amps
- Components are 24 VAC, powered by a transformer in the control cabinet. A pneumatic interface is available for systems ordered with pneumatic control.
- Maximum distance from control cabinet to Ultra-sorb Model XV is 50' (15 m).

mc_101410_0820

OM-7533

Model XV: Mounting

Figure 11-1:
Ultra-sorb Model XV in an air handler (horizontal airflow only)

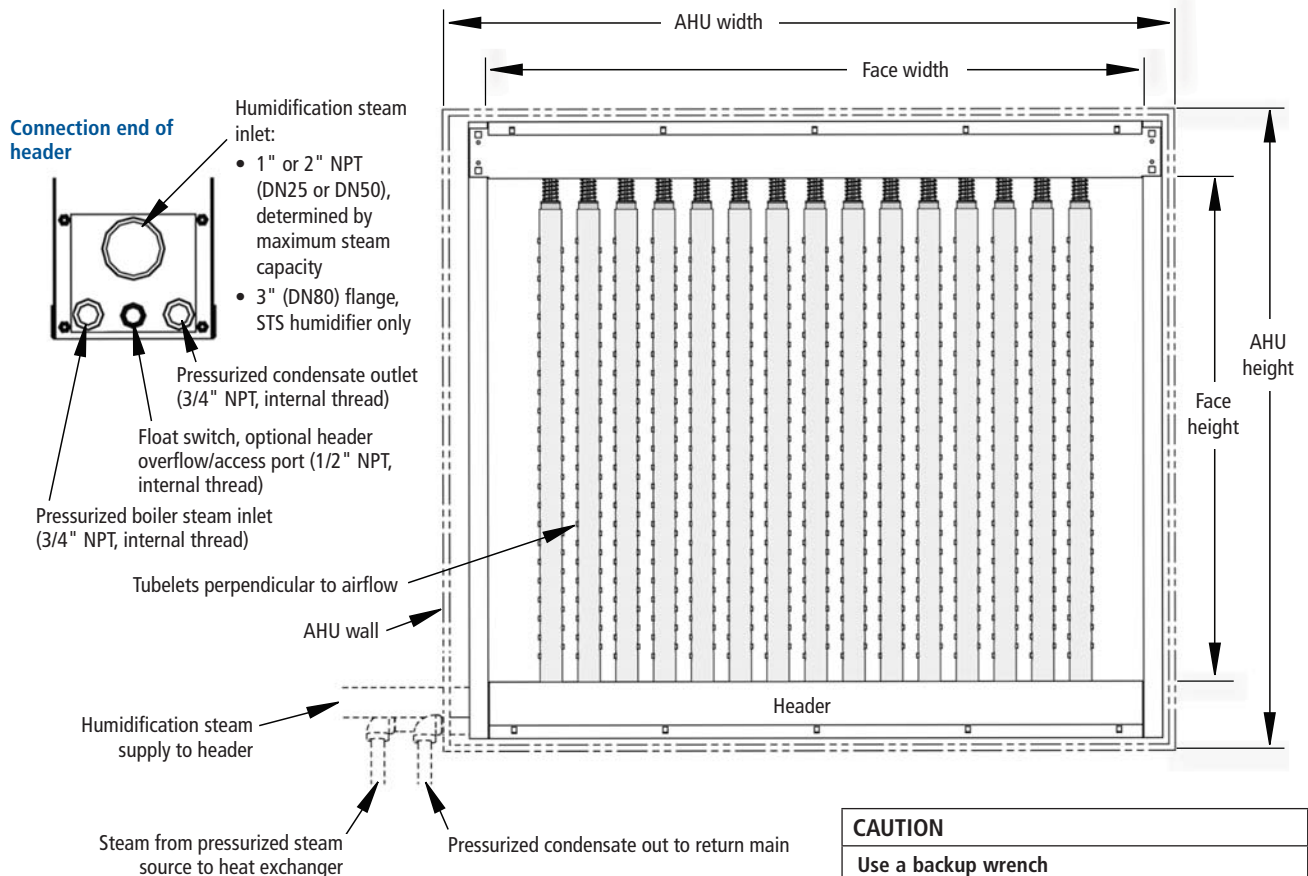

CAUTION

Use a backup wrench

Use a backup wrench on all plumbing connections. Failure to use a backup wrench could cause damage to the Ultra-sorb Model XV.

Notes:

1. Dashed lines indicate provided by installer.
2. See Pages 18-19 for location guidelines. See Page 12 for trap clearance alternatives.
3. Steam supply line to unit, and piping, are not included.
4. Dispersion tubes are available on 3", 6", 9" and 12" (15, 150, 225, and 300 mm) centers.
5. Ultra-sorb humidifiers will be assembled, crated, and shipped intact in all sizes up to 98" (2490 mm) overall height. Any Ultra-sorb can be shipped unassembled by request, requiring field assembly.
6. Standard sizes are 12" x 12" up to 144" x 144" in 1" increments (305 x 305 mm up to 3660 x 3660 mm in 25 mm increments). Larger sizes are available.
7. Heat exchanger requires 5 psig (35 kPa) minimum steam pressure.

Mounting in an air handling unit

- Metal support frames should be anchored to the air handler casing.
- To avoid damaging the header and heat exchanger, drill or screw through the header assembly only where shown in the *Ultra-sorb Model XV Steam Dispersion Panel Installation, Operation, and Maintenance Manual* (available at www.dristeem.com). Screws and drill bits must not penetrate more than 3/4" (20 mm) into the header assembly.
- Recommended fasteners for mounting the Ultra-sorb to a metal support frame are 1/4"-20 nuts and bolts or #12 self drilling and tapping screws.
- DRI-STEEM recommends fastener spacing not to exceed 6" (150 mm).
- When Ultra-sorb Model XV is installed in bypass air applications additional bracing is advised for the unsupported side(s).
- Install the panel level. If slope cannot be avoided, ensure that the slope is toward the drain end of the panel.

Model XV: Connections

Figure 12-3
Ultra-sorb Model XV alternate piping

Alternate trap piping for minimal clearance

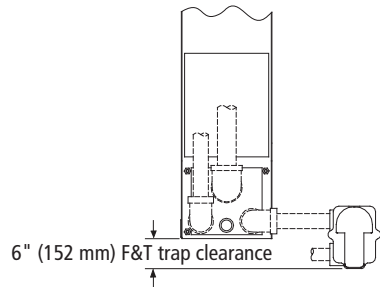

Note: Dashed lines indicate provided by installer.

mc_051811_1026

OM-7655

Figure 12-1:
Ultra-sorb Model XV piping components (with float switch),
pressurized steam source

Standard trap piping

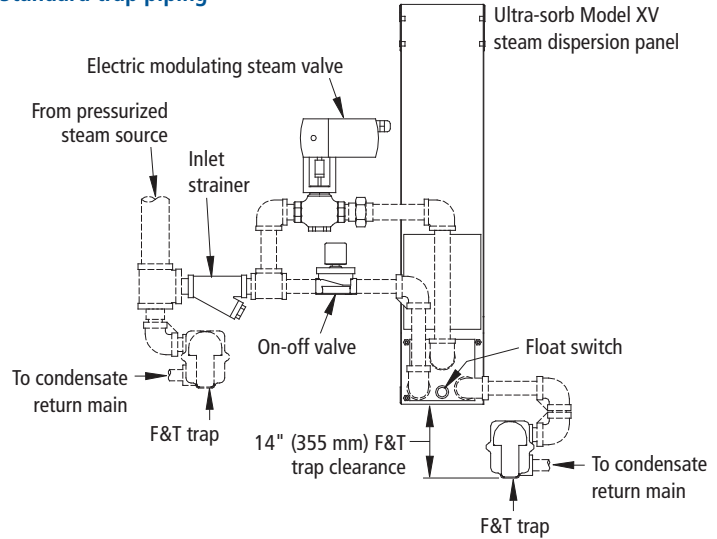

Note: Dashed lines indicate provided by installer.

mc_051811_1025

OM-7656

Figure 12-2:
Ultra-sorb Model XV piping components (with temperature switch),
pressurized steam source

Standard trap piping

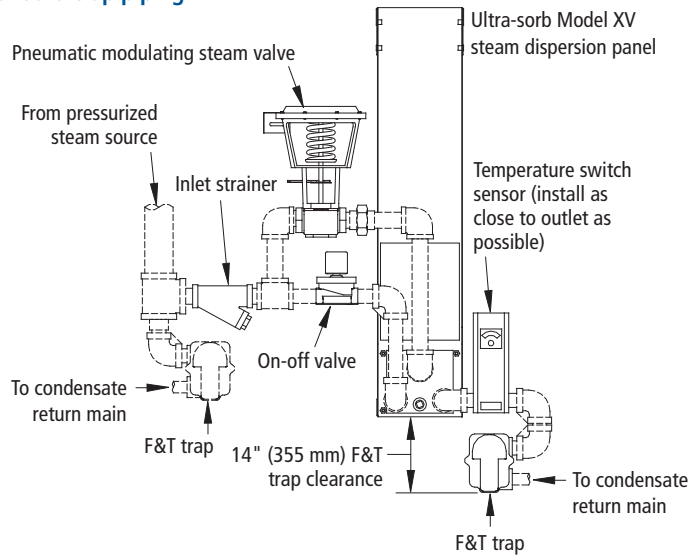

Note: Dashed lines indicate provided by installer.

mc_101410_0800

OM-7536

Model XV: Connections

Figure 13-1:
Ultra-sorb Model XV piping with STS humidifier

Steam to heat exchanger from pressurized steam source,
humidification steam from STS humidifier

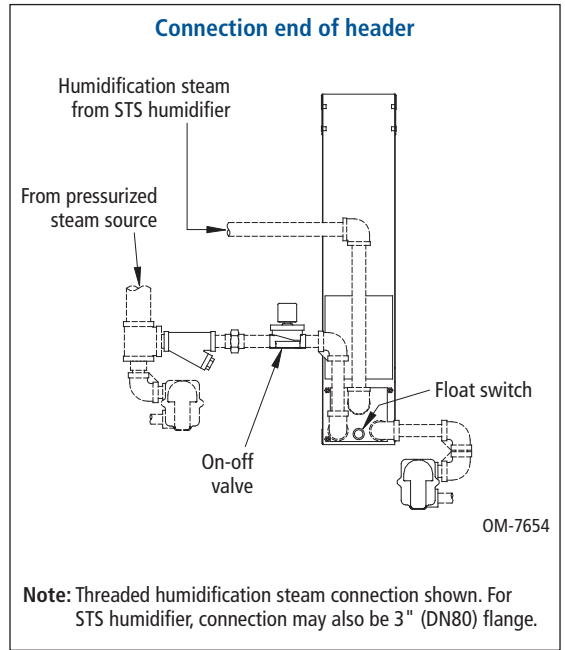
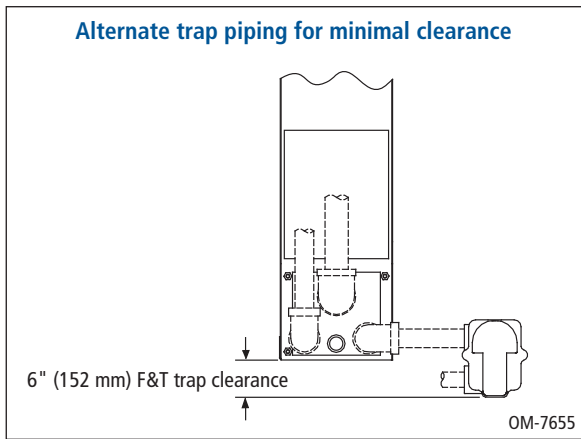
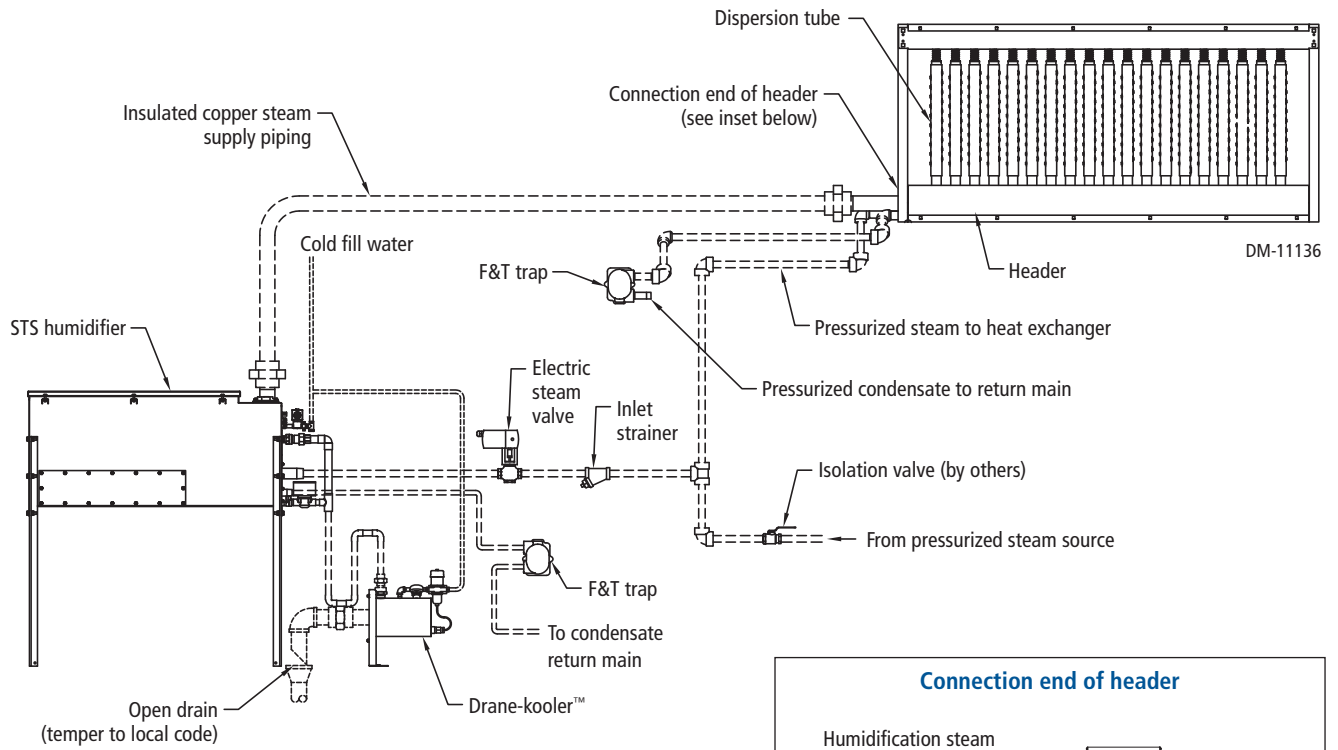

Note: Dashed lines indicate provided by installer.

Models LV and LH: Operation and components

Ultra-sorb Model LV

- Vertical tubes
- Suitable for AHUs or ductwork
- Use when duct height is greater than duct width
- May use with pressurized or nonpressurized steam (horizontal airflow only)

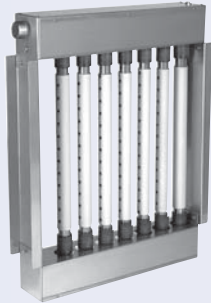

Ultra-sorb Model LH

- Horizontal dispersion tubes
- Suitable for AHUs or ductwork
- Use when duct width is greater than duct height
- May use with pressurized steam in a vertical or horizontal airflow; may use with nonpressurized steam in a vertical airflow



Principle of operation and components (see Figure 14-1)

1. Steam enters steam supply header

Pressurized steam from a boiler or nonpressurized steam from a DRI-STEEM steam generator enters the supply header/separator after passing through a modulating steam control valve.

2. Steam enters dispersion tubes

Steam flows through the dispersion tubes and into the airstream. Dispersion tube diagonal end cuts capture only the driest steam from the center of the header. Calibrated thermal resin tubelets allow only the driest steam to exit into the airstream.

The dispersion tubes operate drip-free without steam jackets, so no unnecessary heat is added to the airstream when the humidifier is idle.

High-Efficiency Insulated Dispersion Tubes, available as a new or retrofit option, provide up to an 85% reduction in wasted energy by significantly reducing airstream heat gain and condensate production. See Pages 9 and 15 for more information.

3. Condensate flows to condensate return header and drain

Any condensate generated in the dispersion tubes flows by gravity to the condensate return header to the condensate drain.

Figure 14-1:
Ultra-sorb Models LV and LH components

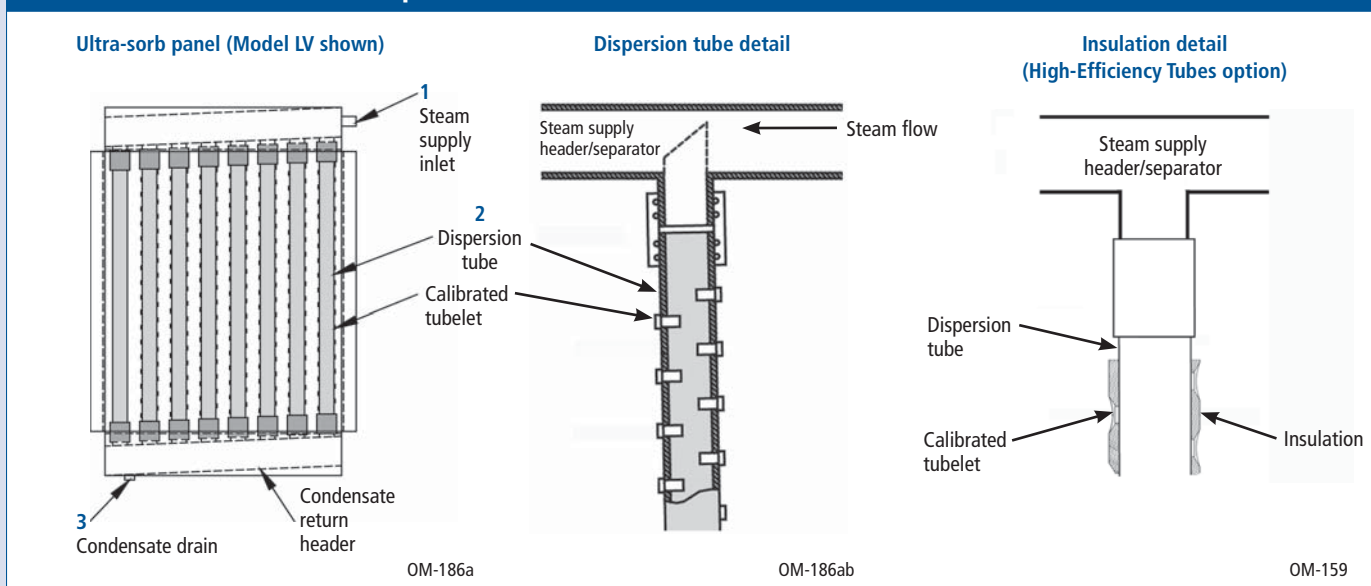

Models LV and LH: Operation and components

High-Efficiency Insulated Tubes retrofit option

Engineered for existing dispersion systems, DRI-STEEM's High-Efficiency Tubes are available as a retrofit option for existing Ultra-sorb Models LV and LH and Rapid-sorb® steam dispersion assemblies.

Energy efficiencies and water savings not previously available are now possible as upgrades to currently installed steam dispersion panels. See Page 9 for a complete description of the benefits of High-Efficiency Tubes.

Ordering and retrofitting are easy

Instructions are provided in the *High-efficiency Tubes Retrofit Brochure* on the Literature page of our website: www.drirsteem.com

Short payback

Retrofit High-Efficiency Tubes have a short payback period — usually less than two years.

For an application-specific payback analysis, contact DRI-STEEM at 800-328-4447 or your local DRI-STEEM Representative.

Retrofitting is easy!

Remove the existing tubes

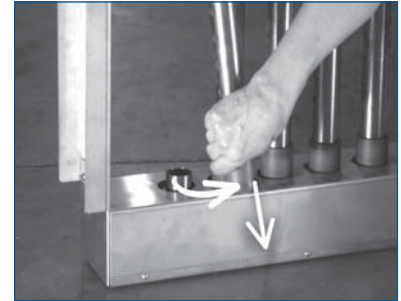

Install the High-Efficiency Tubes

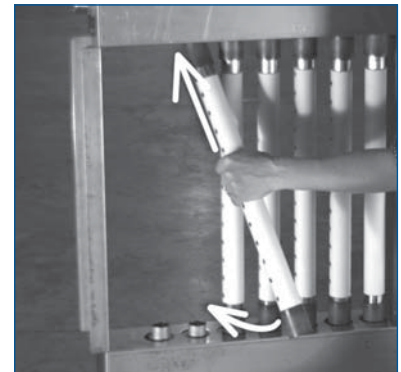

DRI-STEEM® High-efficiency Dispersion Tube Payback Estimator Rev V1.3.14

City similar to your location	Chicago, IL	<small>To estimate payback by investing in DRI-STEEM High efficiency dispersion tubes, enter the appropriate information in the drop-down boxes. Additional parameters located on the "Config" tab</small>
Natural gas rate (\$/1000Cu Ft=\$/therm x 10)	11.9 \$/1000 cu ft	
Electric rate	10.8 Cents/kWh	
Humidification Water rate	\$0.0045 Per gallon	<small>The estimator generates gas & electric paybacks based on TMY2 weather data for the selected region. It estimates modulated control run hours and shows the results in the lower left.</small>
Drain (sewer) cost per gallon	\$0.0040 Per gallon	
District Steam rate	\$10.000 per 1000 Lb	
758 FPM Feet Per Minute	Airflow 24,000 CFM	<small>To analyze the investment based on run hours other than estimated from the TMY2 data, manually select hours in the bottom drop-down box. Manual results shown on the bottom right.</small>
% outdoor air	50%	
Airflow temperature at dispersion panel	55 F	<small>Notes: - Accumulates water, cooling and vaporization expenses associated with humidifying ventilation air only - Minimum modulation rate - fixed 5% - Colored blocks & text highlight potential issues. Verify entry and disregard highlight if entered correctly</small>
Space temperature	68 F	
Space RH	55%	
Drane-kooler™	Drane-kooler™ used	
To manually set humidifier run time, select	6,000 Hrs/Yr	

Estimated Retrofit Payback

Based on TMY2 data using 5385 run hours:		Using manually entered 6000 run hours:	
\$9,298 Per Year	0.87 Years	Electric	0.78 Years \$10,361 Per Year
\$4,496 Per Year	1.80 Years	Gas	1.62 Years \$5,010 Per Year
\$3,909 Per Year	2.08 Years	District Steam	1.87 Years \$4,356 Per Year
59,314 Gallons/yr saved!		Water	66,093 Gallons/yr saved!
\$1,438 Per Year			\$1,603 Per Year
46 lbs steam & 44,962 btu/hr saved!			51 lbs steam & 50,101 btu/hr saved!
Electric = 109,296 lbs CO2/yr	Carbon Dioxide	Electric = 121,788 lbs CO2/yr	
Gas = 33,723 lbs CO2/yr	Reductions	Gas = 37,577 lbs CO2/yr	

The energy saved by a DRI-STEEM dispersion panel with High-Efficiency Tubes will more than make up for the cost of replacing any uninsulated steam dispersion assembly.

Model LV: Dimensions, capacity

**Table 16-1:
Ultra-sorb Model LV and LH
tube capacity***

Insulated		Uninsulated	
lbs/hr	kg/h	lbs/hr	kg/h
86	39	80	36

Note:

* For Model LV, if face height is <26" (660 mm), tube quantity per panel may need to increase to compensate for reduced capacity of short tubes. For Model LH, if face width is <25" (635 mm), tube quantity per panel may need to increase to compensate for reduced capacity of short tubes.

Consult DRI-STEEM or see Dri-calc for the correct calculation.

mc_010709_0710

**Figure 16-1:
Ultra-sorb Model LV dimensions**

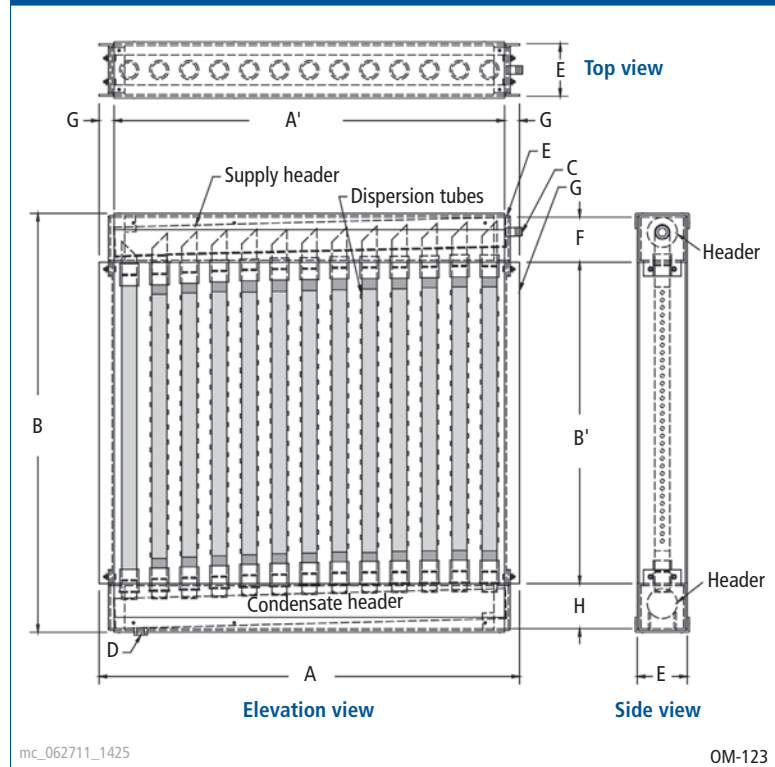

mc_062711_1425

OM-123

**Table 16-2:
Ultra-sorb Model LV dimensions**

A Unit width	15" (380 mm) min, 147" (3735 mm) max, in 1" (25 mm) increments
A' Face width	12" (305 mm) min, 144" (3660 mm) max, in 1" (25 mm) increments
B Unit height	21" (530 mm) min, 156" (3960 mm) max, in 1" (25 mm) increments Shipped unassembled by request or if unit height is more than 98" (2490 mm)
B Face height	12" (305 mm) min, 144" (3660 mm) max, in 1" (25 mm) increments
C Steam inlet diameter	Determined by maximum steam capacity
D Condensate drain	3/4" pipe thread (DN20)
E Header enclosure (front to back)	For 3" (DN80) and 4" (DN100) headers, E = 5" (127 mm); for 5" (DN125) header, E = 6" (152 mm); for 6" (DN150) header, E = 7" (178 mm)
F Header enclosure (top to bottom)	For 3" (DN80) header F = 4.5" (114 mm); for 4" (DN100) header, F = 5.5" (140 mm); for 5" (DN125) header, F = 6.5" (165 mm); for 6" (DN150) header F = 7.5" (191 mm)
G Mounting flange	1.5" (38 mm)
H Condensate header enclosure	4.5" (114 mm)

Note: Header dimensions are determined by capacity. See Tables 17-1 and 17-2.

mc_050808_1215

Model LH: dimensions, capacity

Figure 17-1:
Ultra-sorb Model LH dimensions

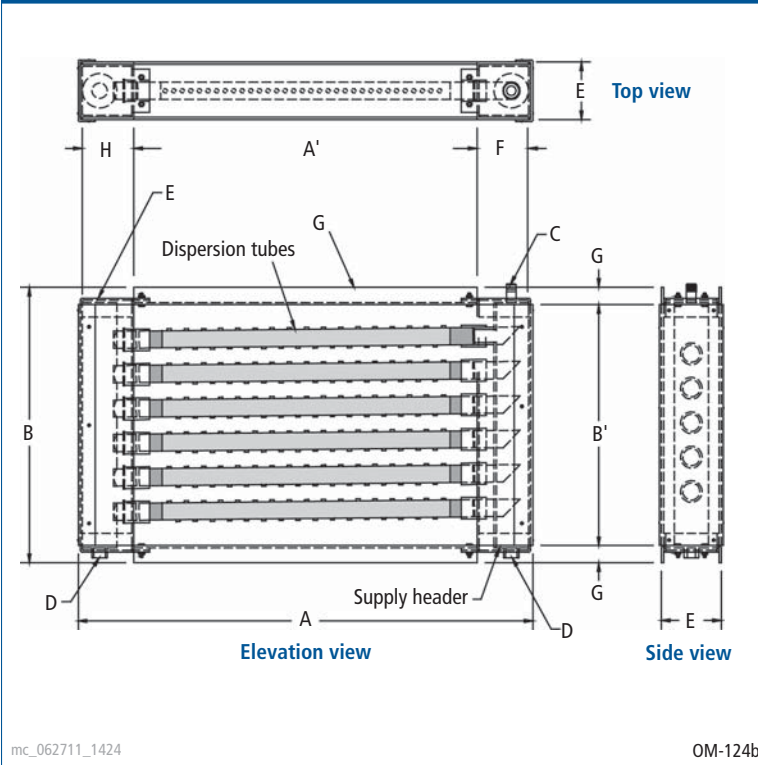

mc_062711_1424

OM-124b

Table 17-1:
Nonpressurized steam header capacities

Header capacity		Header diameter	
lbs/hr	kg/h	inches	DN
300	135	3	80
600	270	4	100
1100	500	5	125
1850	820	6	150

mc_062711_1426

Table 17-2:
Boiler steam header capacities

Header capacity		Header diameter	
lbs/hr	kg/h	inches	DN
980	445	3	80
1750	793	4	100
2750	1245	5	125
4000	1815	6	150

mc_062711_1427

Table 17-3:
Ultra-sorb Model LH dimensions

A Unit width	21" (530 mm) min, 129" (3280 mm) max, in 1" (25 mm) increments
A' Face width	12" (305 mm) min, 120" (3050 mm) max, in 1" (25 mm) increments
B Unit height	15" (380 mm) min, 123" (3125 mm) max, in 1" (25 mm) increments Shipped unassembled by request or if unit height is more than 98" (2490 mm)
B' Face height	12" (305 mm) min, 120" (3050 mm) max, in 1" (25 mm) increments
C Steam inlet diameter	Determined by maximum steam capacity
D Condensate drain	3/4" pipe thread (DN20)
E Header enclosure (front to back)	For 3" (DN80) and 4" (DN100) headers, E = 5" (127 mm); for 5" (DN125) header, E = 6" (152 mm); for 6" (DN150) header, E = 7" (178 mm)
F Header enclosure (top to bottom)	For 3" (DN80) header, F = 4.5" (114 mm); for 4" (DN100) header, F = 5.5" (140 mm); for 5" (DN125) header, F = 6.5" (165 mm); for 6" (DN150) header, F = 7.5" (191 mm)
G Mounting flange	1.5" (38 mm)
H Condensate header enclosure	4.5" (114 mm)

Note: Header dimensions are determined by capacity. See Tables 17-1 and 17-2.

mc_062711_1430

Choosing a location for Ultra-sorb

Figure 18-1:
Placing a dispersion assembly in an air handling unit

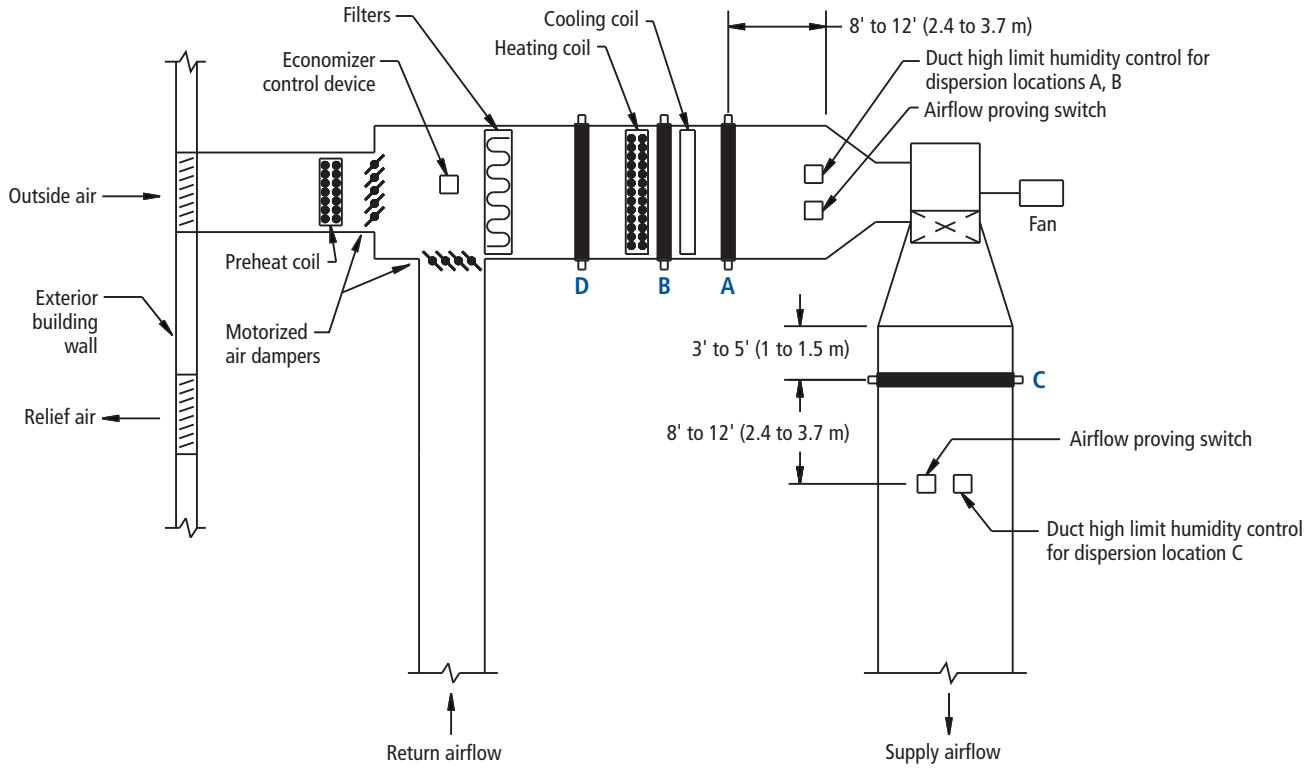

mc_092507_1530

DC-1081

Choosing a location for Ultra-sorb

Determine humidifier placement

Check available non-wetting distance, and review Figure 18-1. Dispersed steam must be absorbed into the airflow before it comes in contact with duct elbows, fans, vanes, filters, or any object that can cause condensation and dripping.

Placement in an air handling unit

- **Location A is the best choice.** Installing downstream from heating and cooling coils provides laminar flow through the dispersion unit; plus, the heated air provides an environment for best absorption.
- **Location B is the second-best choice.** However, in change-over periods, the cooling coil will eliminate some moisture for humidification.
- **Location C is the third-best choice.** Air leaving a fan is usually very turbulent and can cause vapor to not absorb at the expected non-wetting distance. Allow for more distance if installing downstream from a fan.
- **Location D is the poorest choice.** The cooler air at this location requires an increased non-wetting distance.

mc_062111_0715

Model LV: Mounting

Figure 20-1:
Mounting Ultra-sorb Model LV in a horizontal airflow (pressurized steam application shown)

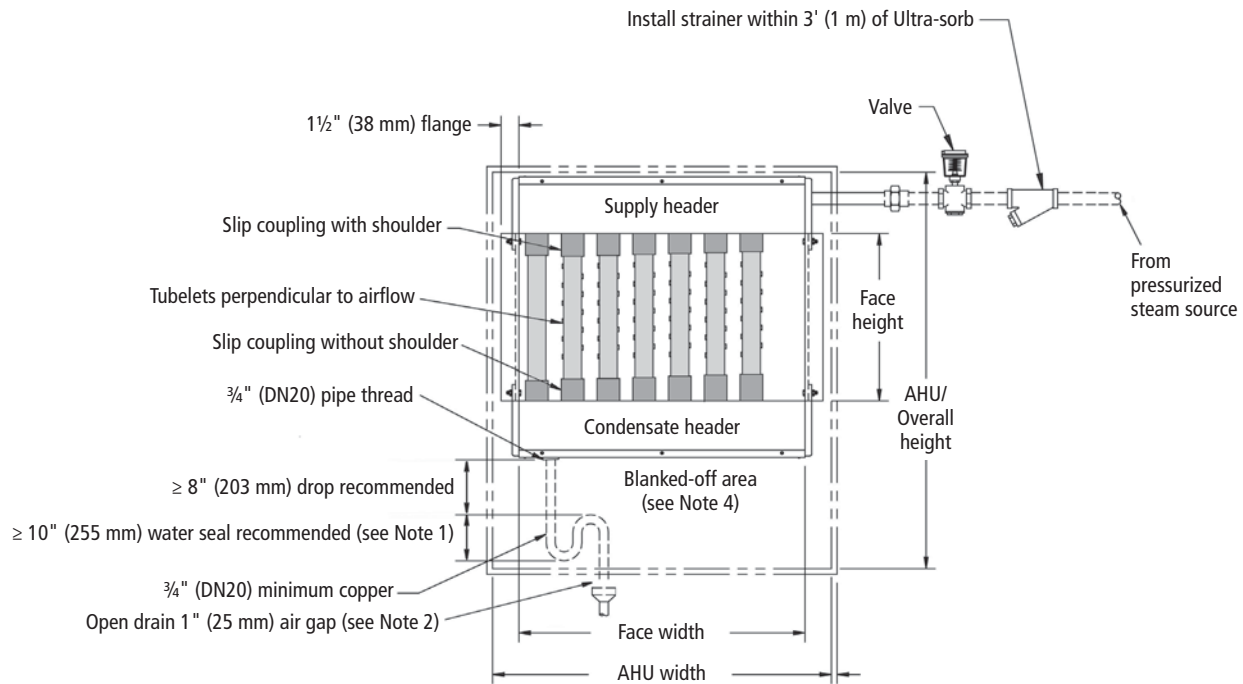

Dashed lines indicate provided by installer.

Notes:

1. For pressurized steam applications we recommend installing a 10" (255 mm) minimum water seal or a float and thermostatic (F&T) trap. F&T traps are approximately 7" (180 mm) in height.
2. Locate air gap only in spaces with adequate temperature and air movement to absorb flash steam; otherwise, condensation may form on nearby surfaces. Refer to governing codes for drain pipe size and maximum discharge water temperature.
3. When mounting an Ultra-sorb in a duct, headers and flanges are mounted outside the duct.
4. 100% of the airflow must pass through the Ultra-sorb, which means that any openings surrounding it must be sealed. The blanked-off area below the Ultra-sorb provides clearance height for F&T traps, water seals, and condensate piping connections.

DC-1097

Model LH: Mounting

**Figure 21-1:
Mounting Ultra-sorb Model LH in a horizontal airflow (pressurized steam applications only)**

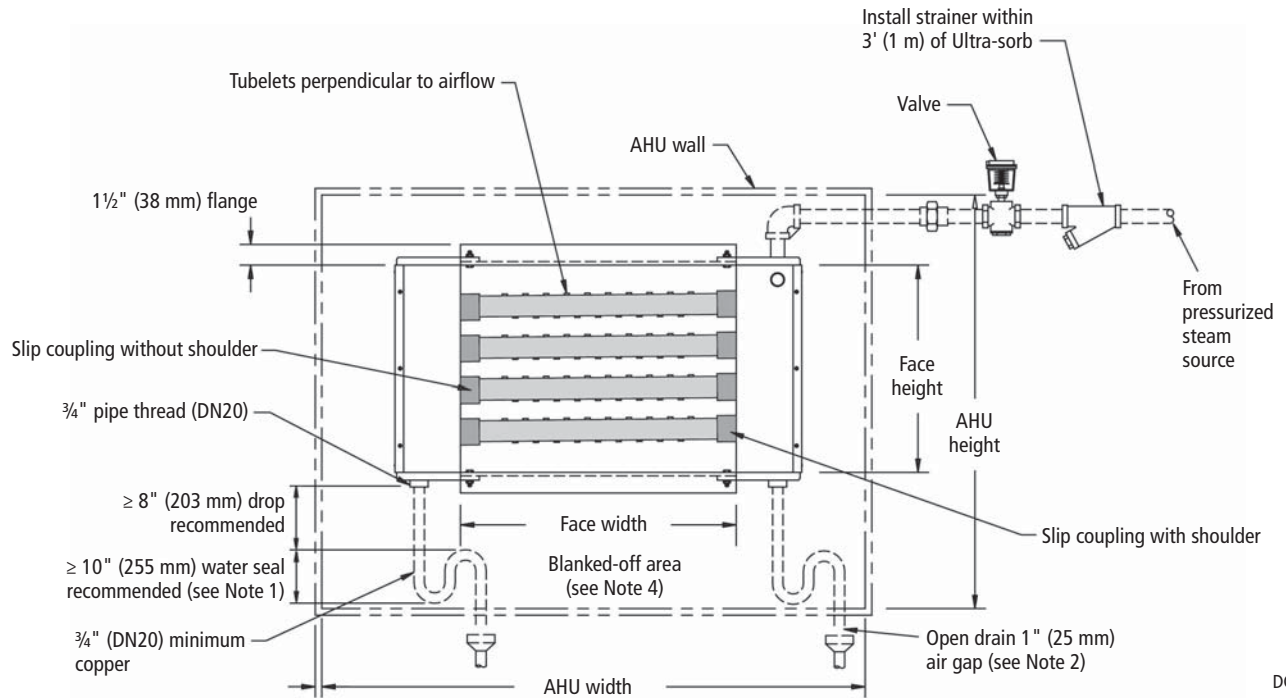

Notes:

1. A water seal or trap is required on each condensate line. For pressurized steam applications we recommend installing a 10" (255 mm) minimum water seal or an F&T trap. F&T traps are approximately 7" (180 mm) in height.
2. Locate air gap only in spaces with adequate temperature and air movement to absorb flash steam; otherwise, condensation may form on nearby surfaces. Refer to governing codes for drain pipe size and maximum discharge water temperature.
3. When mounting an Ultra-sorb in a duct, headers and flanges are mounted outside the duct.
4. 100% of the airflow must pass through the Ultra-sorb, which means that any openings surrounding it must be sealed. The blanked-off area below the Ultra-sorb provides clearance height for F&T traps, water seals, and condensate piping connections.
5. For Ultra-sorb Model LH in a vertical airflow, see the *Ultra-sorb Models LV and LH Steam Dispersion Panels Installation, Operation, and Maintenance Manual* (available at www.dristeem.com).
5. Dashed lines indicate provided by installer.

mc_060911_1440

Models LV and LH: Connections

Figure 22-1:
Ultra-sorb Models LV and LH steam inlet types

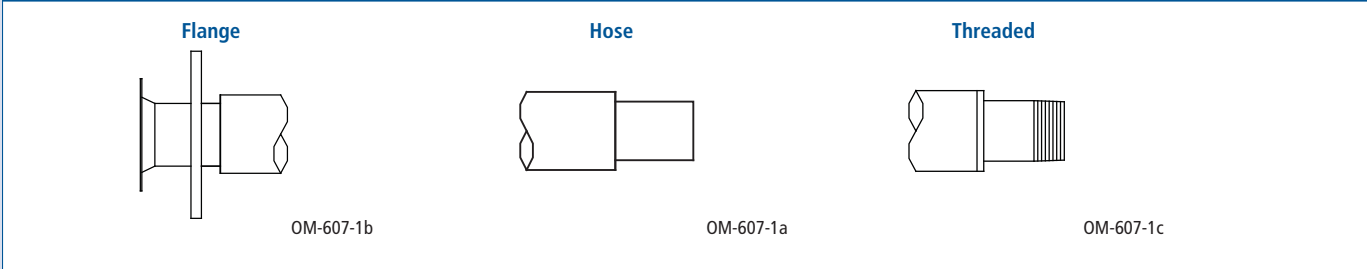

Figure 22-2:
Ultra-sorb Models LV and LH steam inlet and condensate outlet positions

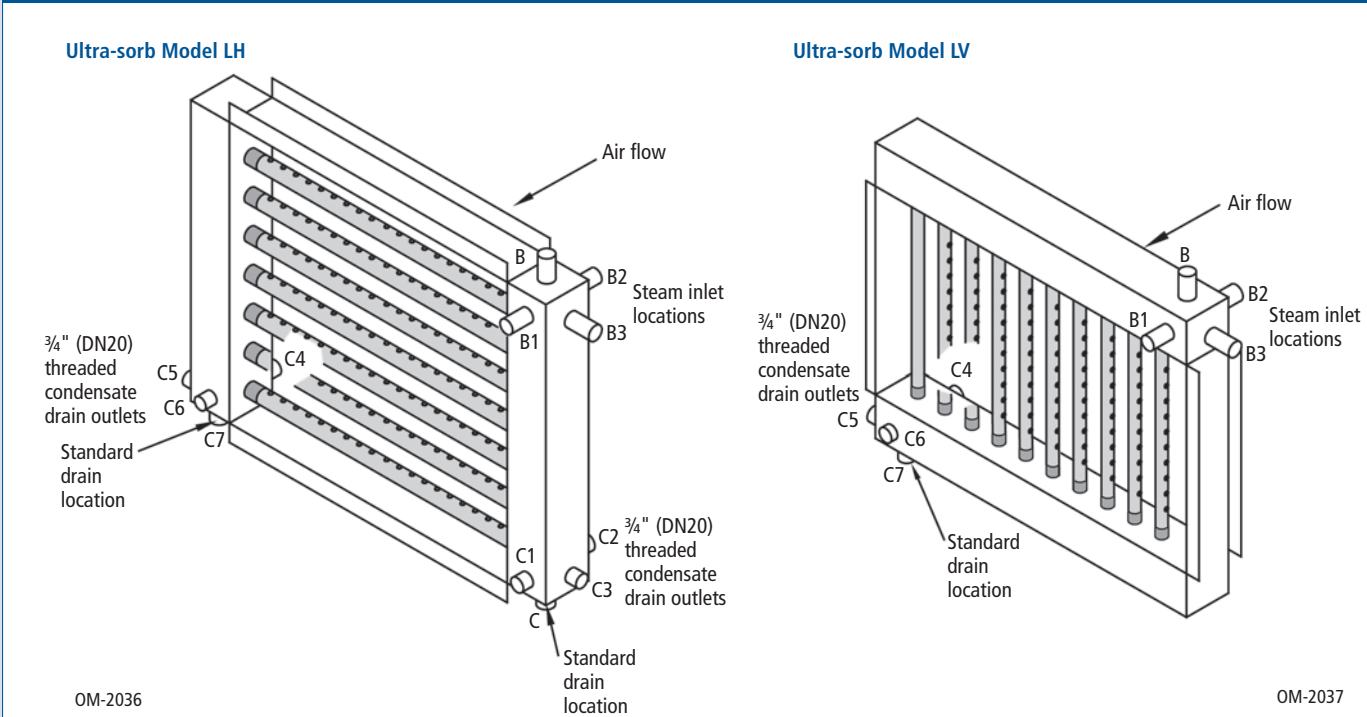

Table 22-1:
Standard length steam inlet extends beyond header

Inlet type	Inlet nominal diameter, inches (DN)										
	1/2" (15)	3/4" (20)	1" (25)	1 1/4" (32)	1 1/2" (40)	2" (50)	3" (80)	4" (100)	5" (125)	6" (150)	
Threaded	2.83" (72 mm)					2.95" (75 mm)	3.95" (93 mm)	—			
Hose	—				2.83" (72 mm)		3.95" (93 mm)	—			
Flange	—						3.95" (93 mm)			5.95" (151 mm)	

Models LV and LH: Connections

Figure 23-1:
Connection to a boiler (pressurized steam applications)

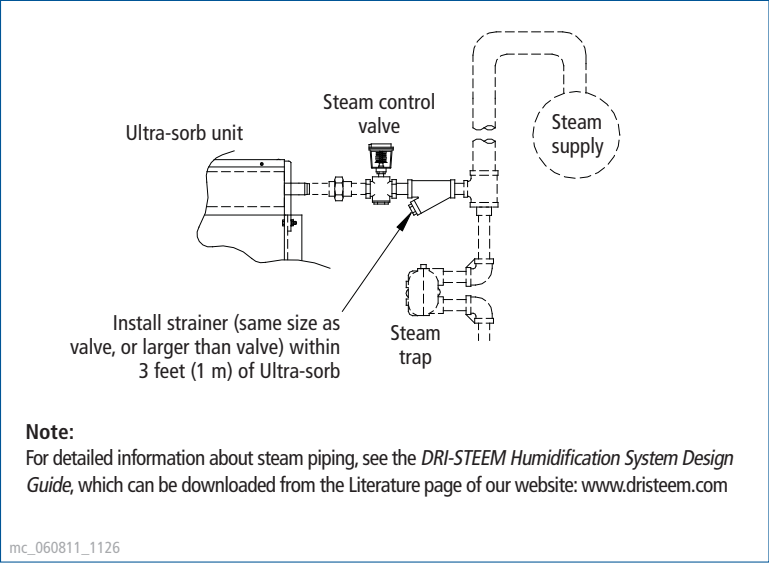

Figure 23-3:
F&T trap dimensions (Models LV and LH)

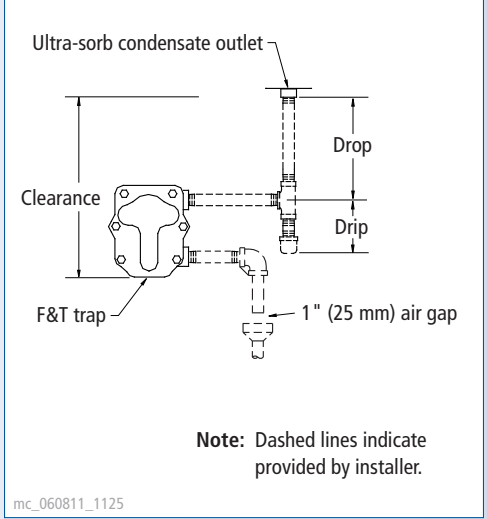

Figure 23-2:
Lifting condensate (Models LV and LH)

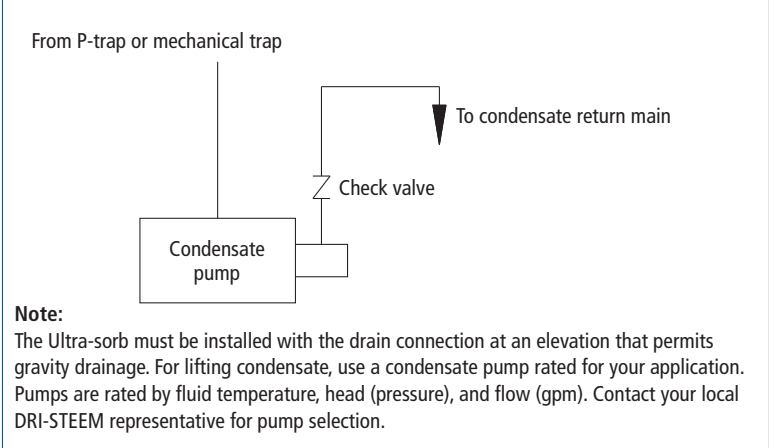
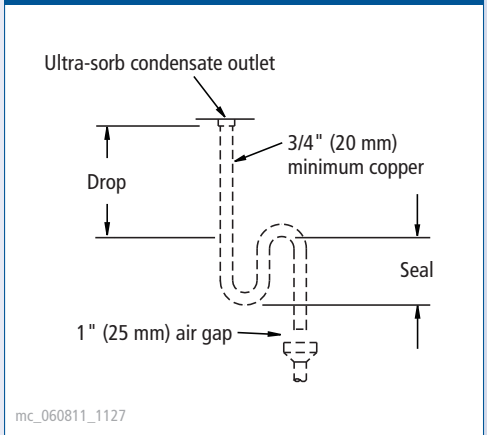

Figure 23-4:
P-trap water seal dimensions (Models LV and LH)



Conserving resources through better performance

Expect quality from the industry leader

For more than 45 years, DRI-STEEM has been leading the industry with creative and reliable humidification solutions. Our focus on quality is evident in the construction of the Ultra-sorb, which features stainless steel construction. DRI-STEEM also leads the industry with a Two-year Limited Warranty and optional extended warranty.

For more information

www.dristeem.com
sales@dristeem.com

For the most recent product information visit our website:
www.dristeem.com

DRI-STEEM Corporation
An ISO 9001:2000 certified company

U.S. Headquarters:
14949 Technology Drive
Eden Prairie, MN 55344
800-328-4447 or 952-949-2415
952-229-3200 (fax)

European office:
Marc Briers
Grote Hellekensstraat 54 b
B-3520 Zonhoven
Belgium
+3211823595 (voice)
+3211817948 (fax)
E-mail: marc.briers@dristeem.com

Continuous product improvement is a policy of DRI-STEEM Corporation; therefore, product features and specifications are subject to change without notice.

DRI-STEEM and Ultra-sorb are registered trademarks or trademarks of DRI-STEEM Corporation, and are filed for trademark registration in Canada and the European community.

© 2011 DRI-STEEM Corporation



Form No. US-CAT-1111

DRI-STEEM conserves resources by designing humidification systems that optimize performance. Systems that perform well save energy and water and, ultimately, cost less to operate and maintain.

Save energy

For applications requiring short absorption, High-Efficiency Dispersion Tubes reduce wasted energy up to 85% by significantly reducing airstream heat gain and condensate production. Available for new and retrofit Ultra-sorb® and Rapid-sorb® steam dispersion panels.



DRI-STEEM's High-Pressure Atomizing Systems disperse unheated micro-fine water particles into airstreams or open spaces. As atomized water droplets evaporate, air temperature drops, reducing the cooling load. This provides significant energy savings when humidifying and cooling simultaneously.



Save water

Ultra-sorb Model XV eliminates water waste and reduces airstream heat gain, energy costs, and boiler chemical use. Available for STS® steam-to-steam humidifiers and all pressurized steam applications.

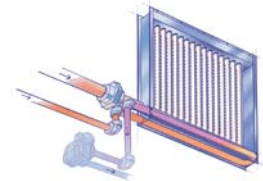

Optimize performance

DRI-STEEM's most advanced controller, Vapor-logic®4 continuously monitors space conditions to align humidifier output with demand. The result is accurate, responsive control.



Your DRI-STEEM representative is: