

READ AND SAVE THESE INSTRUCTIONS
This manual must be left with the owner and should be accessible for reference.

ULTRA-SORB[®]

STEAM DISPERSION TUBE HUMIDIFIER PANEL

For Applications
Using Steam From A Boiler
or
From Any DRI-STEEM
Steam Generating Humidifier.

User's/Installation Instructions
and
Maintenance Operations Manual

For Toll-Free Technical Support,
Call 1-800-328-4447

DRI **STEEM**[®]
HUMIDIFIER COMPANY

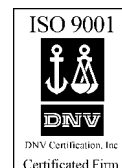

TABLE OF CONTENTS

TO THE PURCHASER AND INSTALLER

Thank you for purchasing our ULTRA-SORB® steam dispersion tube humidifier panel. We have designed and built this equipment to give you complete satisfaction and trouble-free service for many years. Familiarizing yourself with this manual will help ensure you proper operation of the equipment for years to come.

DRI-STEEM Humidifier Company

Assembly	
Field Assembly of Model LH	3-5
Field Assembly of Model LV	6-8
Installation	
Selecting the Location	9
Placement of the Humidifier Within A System	10-11
Mounting Assembly in Duct Section	12
Mounting ULTRA-SORB in Vertical Duct Section	13
ULTRA-SORB Installation Inside Air Handler	14
Piping	
When Supplying Steam From A Boiler	15
When Supplying Steam From An Evaporative Humidifier	16
Condensate Drainage	17
Mounting	18
Performance Data	19
Replacement Parts	20
Trouble-Shooting Guide	21-22
Maintenance Procedures	23
Warranty	24

FIELD ASSEMBLY OF ULTRA-SORB® LH

ULTRA-SORB Model LH Field Assembly

Please Read Instructions While Assembling

STEP 1 - Unpack

Unpack the ULTRA-SORB components and verify that all items checked off as shipped on the packing list have been received by you.

Note that both the Supply Header Assembly (SHA) and the Condensate Header Assembly (CHA) have a 3/4" half coupling (DN 20) for drain connection at one end (the SHA also has a steam inlet - nipple or tubing) for steam supply connection at the other end.

Refer to Figure 3-1 and arrange the components on the floor or some other large flat working surface, positioning them as indicated in Figure 3-1 with the SHA at the right and the CHA at the left.

Table 3-1: ULTRA-SORB Humidifier Components

Description	Qty.
Supply Header Assembly (SHA) with Internal Shouldered Slip Couplings	1
Condensate Header Assembly (CHA)	1
Mounting Flange	2
Dispersion Tubes with Slip Couplings	varies
1/4-20 x 3/4" Bolt	8
1/4-20 Nut	8
1/4 lock Washer	8

Figure 3-1: ULTRA-SORB Model LH

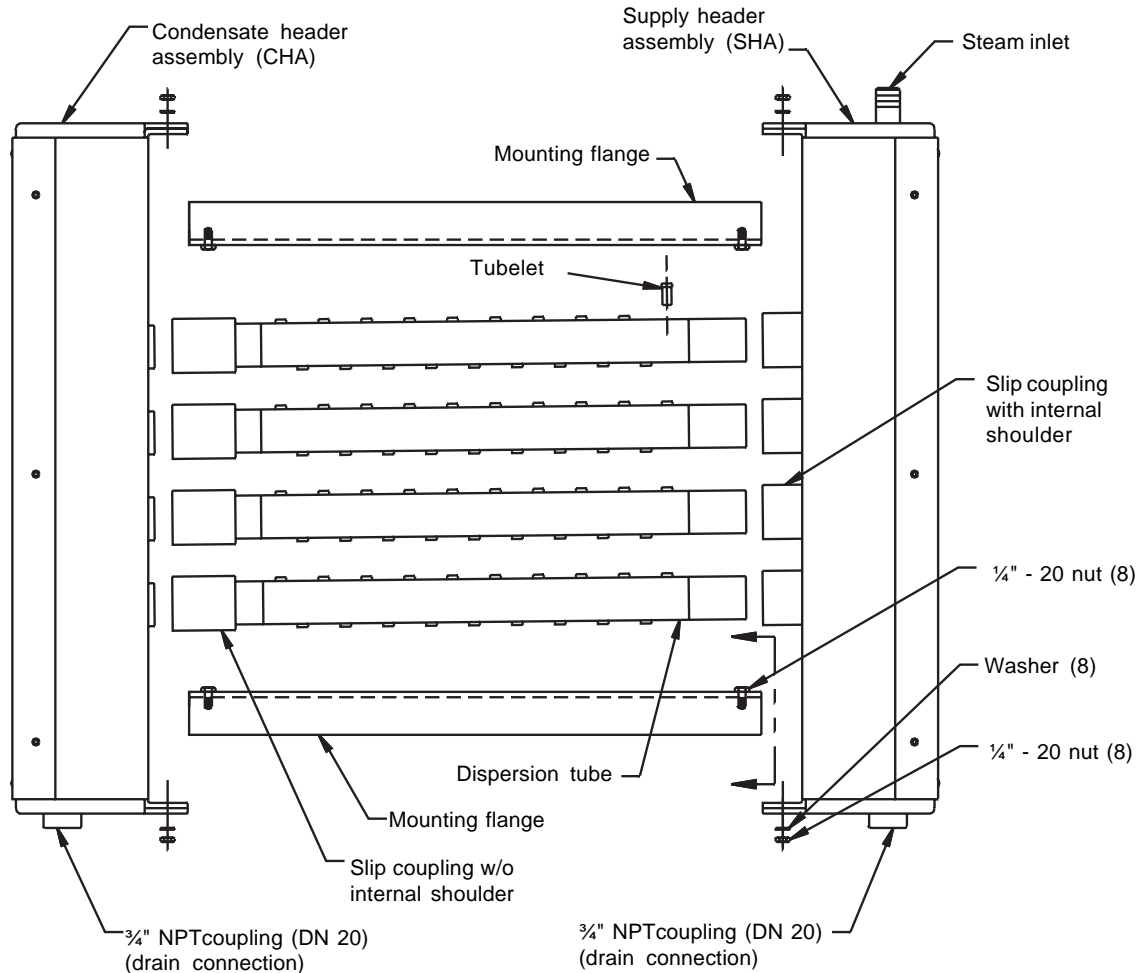

FIELD ASSEMBLY OF ULTRA-SORB® LH

STEP 2 - Bolt the Mounting Flanges to the Supply Header Assembly (SHA)

Refer to Figure 4-1 and 4-2 below.
Attach the two mounting flanges to the SHA as indicated using 1/4-20 bolts with the nuts only finger tightened.

Figure 4-1

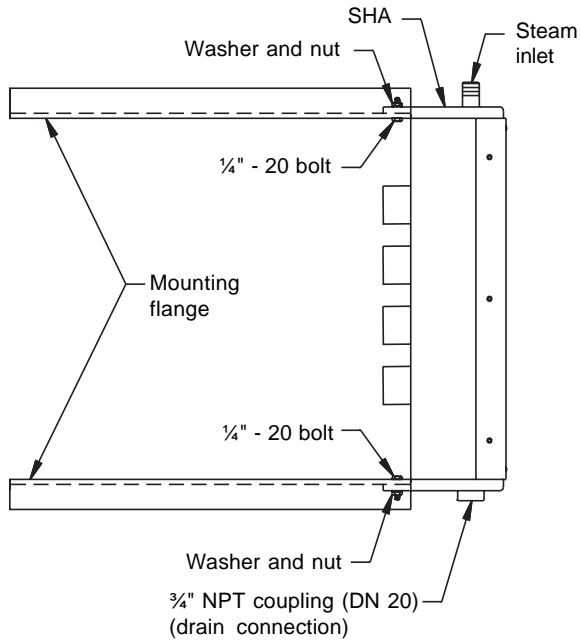

OM-238-2

Figure 4-2: Detail View of Mounting Flange

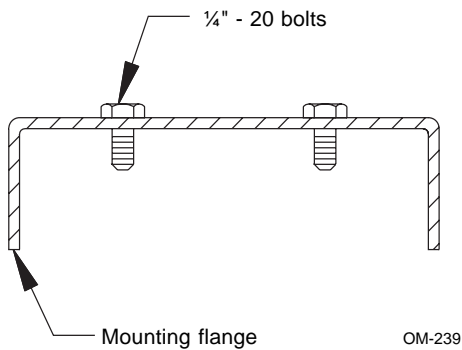

OM-239

STEP 3 - Insert the Dispersion Tubes

Refer to Figure 4-3. Insert the plain ends of the dispersion tubes into the slip couplings already mounted on the SHA (they are factory lubricated internally and if well aligned during insertion no further lubrication should be needed). Push and twist the tube in until it bottoms out on the internal shoulder stop of the adapter. See Figure 4-4 below. **CAUTION:** Use care to avoid cutting the internal O-rings of the adapters.

Figure 4-3

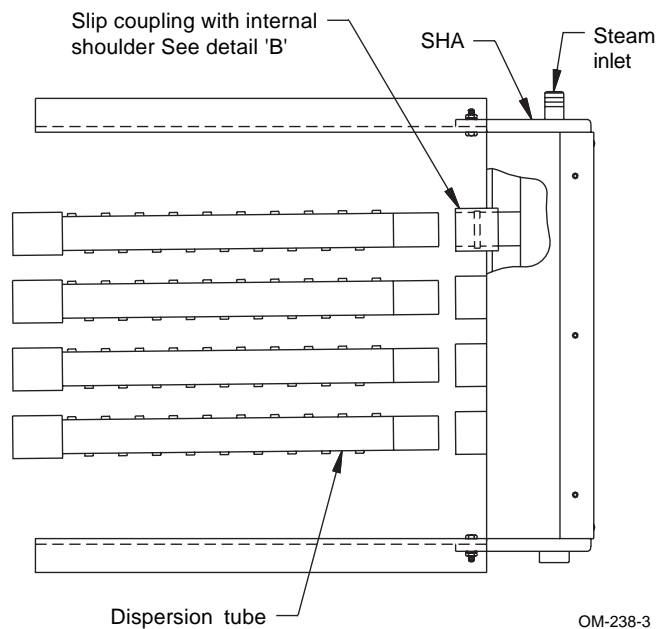

OM-238-3

Figure 4-4: Detail View of Slip Coupling

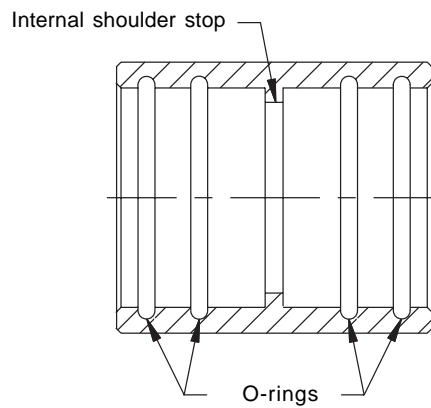

OM-238-6

FIELD ASSEMBLY OF ULTRA-SORB® LH

STEP 4 - Bolt the Mounting Flanges to the CHA

Refer to Figure 5-1 below. First make sure that the slip couplings are pushed far enough onto the dispersion tubes to be at least flush with the tube ends and the 3/4" drain half coupling (DN 20) is properly oriented. Attach the mounting flanges using 1/4-20 bolts and leave the nuts finger tightened.

Figure 5-1

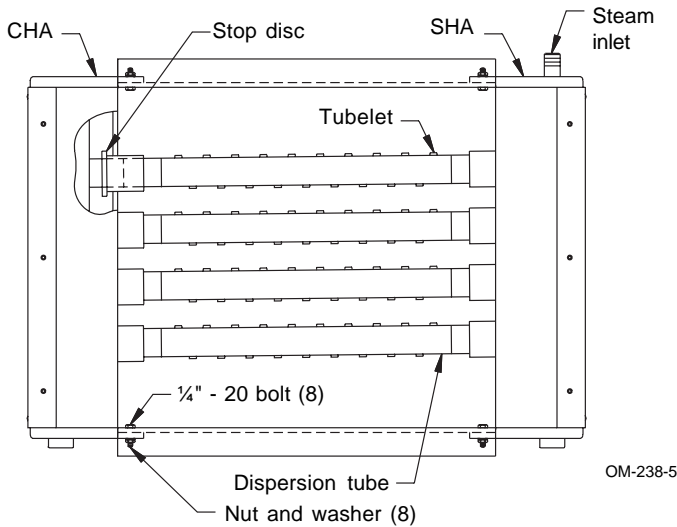

OM-238-5

STEP 5 - Slide the slip couplings onto the CHA outlets and orient the tubelets

SUGGESTION: Gripping the 3/4" drain connection (DN 20) with vise grip pliers and applying a back and forth rolling motion to the header will assist in sliding the slip couplings into place.

Refer to Figure 5-2. It may be necessary to push and twist the slip couplings onto the outlets. Again care must be taken to avoid cutting the internal O-rings. Slide the slip couplings on until they bottom out against the **stop disk**. The steam discharge orifices must be aimed so that they discharge the steam across (perpendicular to) the airstream. Rotate the tubes as needed to accomplish this.

After tightening the 1/4-20 bolts at all 4 corners the ULTRA-SORB panel is ready for installation. See page 9.

Figure 5-2

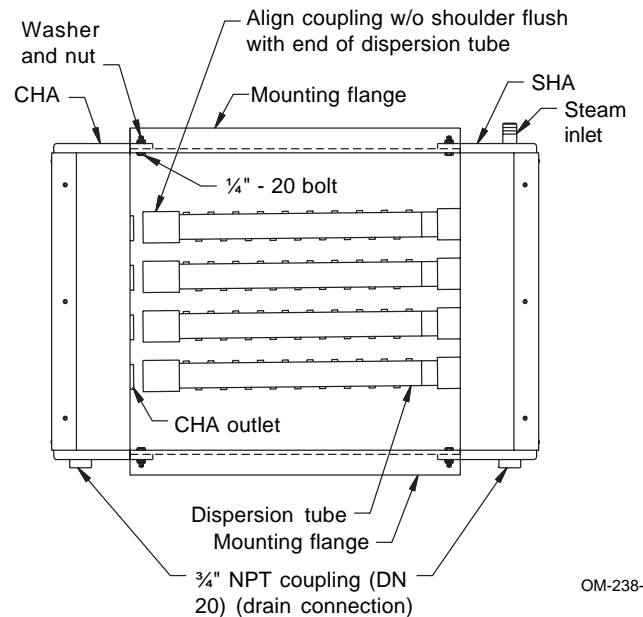

OM-238-4

FIELD ASSEMBLY OF ULTRA-SORB® LV

ULTRA-SORB Model LV Field Assembly

Please Read Instructions While Assembling

STEP 1 - Unpack

Unpack the ULTRA-SORB components and verify that all items checked off as shipped on the packing list have been received by you.

Lay the components on a flat surface as shown in Figure 6-1. Note: Reference positioning of the header assemblies to the 3/4" coupling (DN 20) on the Condensate Header Assembly (CHA). Place this assembly with the 3/4" drain half coupling (DN 20) on your left. The Supply Header Assembly (SHA) has a steam inlet (nipple or tubing) on one end. Place this assembly as shown with the steam connection nipple or tubing pointing to the right.

Table 6-1: ULTRA-SORB Humidifier Components

Description	Qty.
Supply Header Assembly (SHA) with Internal Shouldered Slip Couplings	1
Condensate Header Assembly (CHA)	1
Mounting Flange	2
Dispersion Tubes with Slip Couplings	varies
1/4-20 x 3/4" Bolt	8
1/4-20 Nut	8
1/4 lock Washer	8

Figure 6-1: ULTRA-SORB Model LV

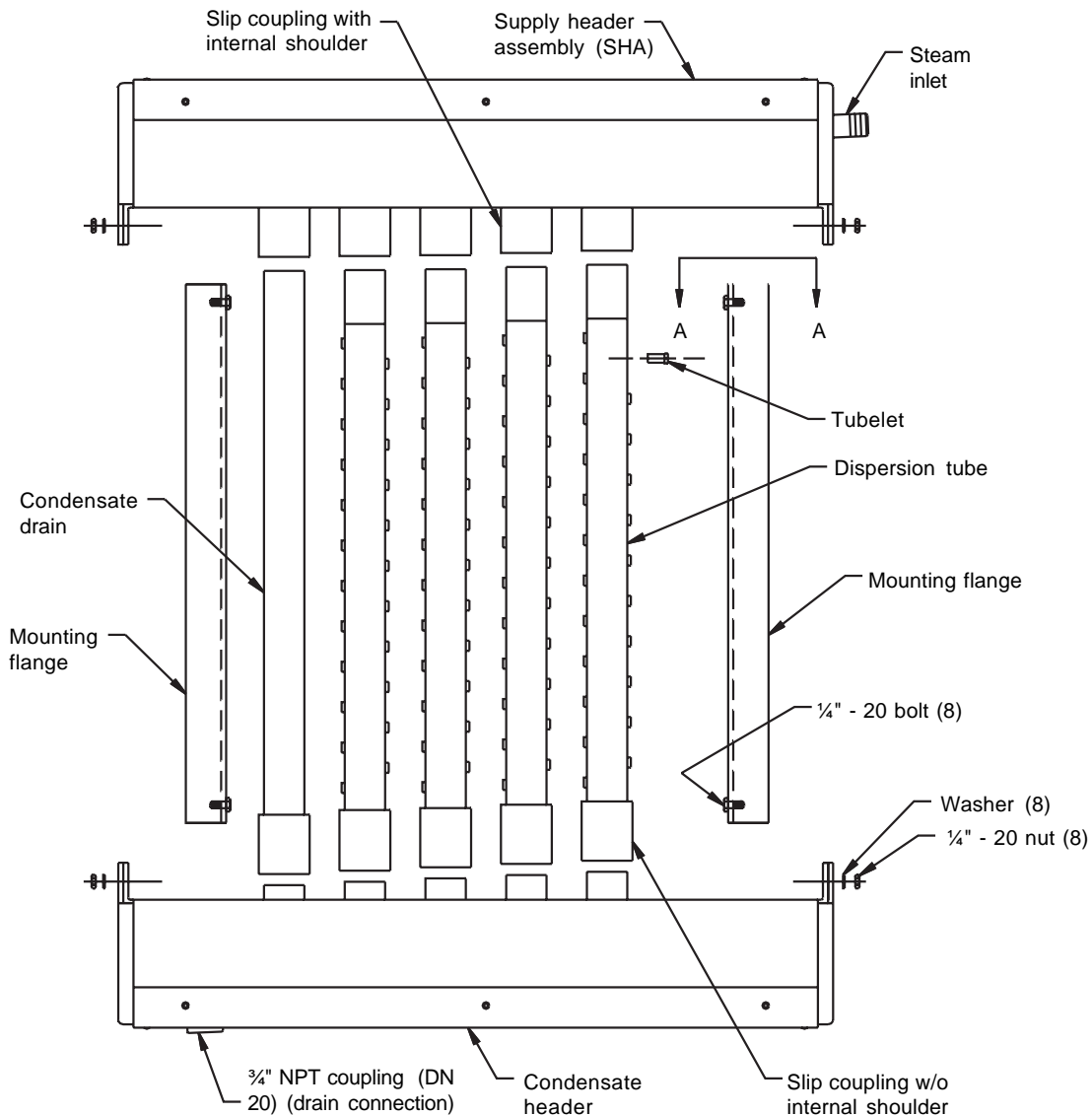

FIELD ASSEMBLY OF ULTRA-SORB® LV

STEP 2 - Bolt the Mounting Flanges to the Supply Header Assembly (SHA)

Refer to Figure 7-1 and 7-2 below. Attach the two mounting flanges as indicated using 1/4-20 bolts with the nuts only finger tightened.

Figure 7-1

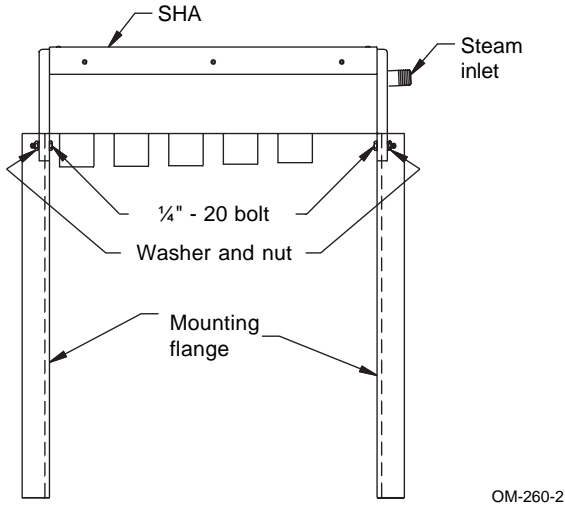

OM-260-2

Figure 7-2: Detail View of Mounting Flange

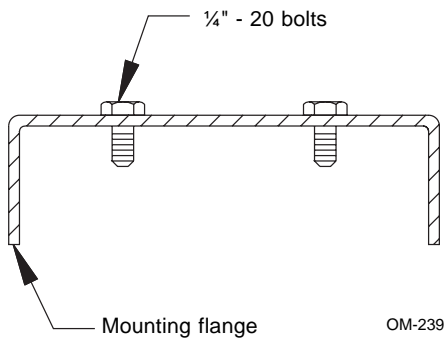

OM-239

STEP 3 - Insert the Dispersion Tubes

Refer to Figure 7-3. Insert the plain ends (less slip coupling) of the dispersion tubes into the slip coupling already mounted on the SHA (they are factory lubricated internally and if well aligned during insertion no further lubrication should be needed). Push and twist the tube in until it bottoms out on the internal shoulder stop of the adapter. See Figure 7-4 below. CAUTION: Use care to avoid cutting the internal O-rings of the adapters.

Figure 7-3

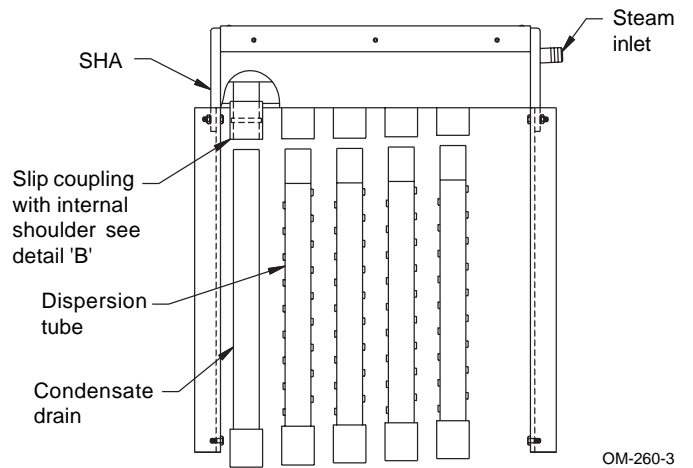

OM-260-3

Figure 7-4: Detail View of Slip Coupling

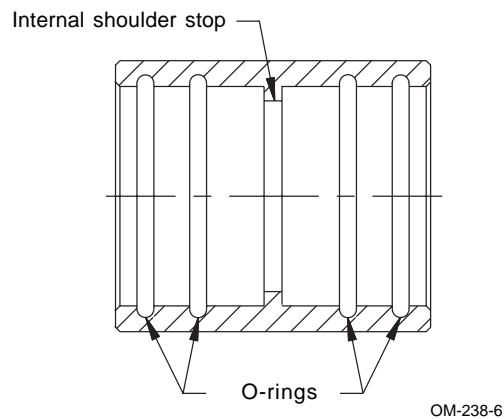

FIELD ASSEMBLY OF ULTRA-SORB® LV

STEP 4 - Bolt the Mounting Flanges to the CHA

Refer to Figure 8-1. First make sure that the slip couplings are pushed far enough onto the dispersion tubes to be at least flush with the tube ends and the 3/4" drain half coupling (DN 20) is properly oriented. Attach the mounting flanges using 1/4-20 bolts and leave the nuts finger tightened.

Figure 8-1

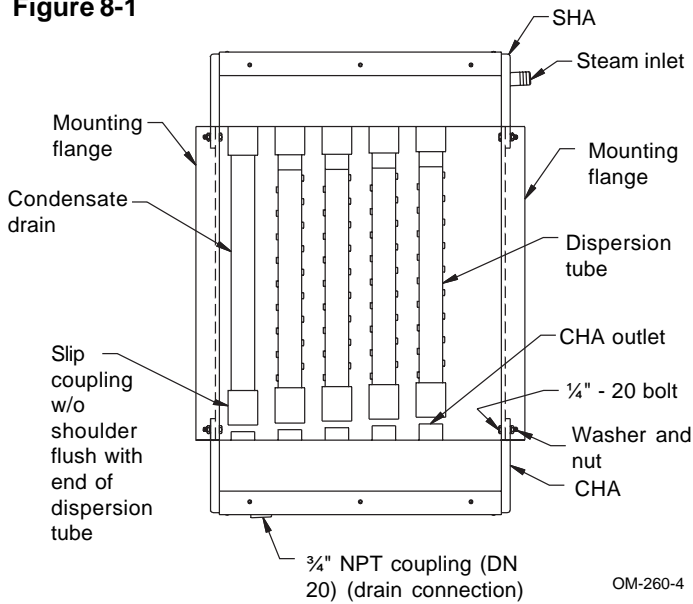

STEP 5 - Slide the slip couplings onto the CHA outlets and orient the tubelets

Refer to Figure 8-2. SUGGESTION: Gripping the 3/4" drain connection (DN 20) with vise grip pliers and applying a back and forth rolling motion to the header will assist in sliding the slip couplings into place.

It may be necessary to push and twist the slip couplings onto the outlets. Again care must be taken to avoid cutting the internal O-rings. Slide the slip couplings on until they bottom out against the **stop disk**. The steam discharge orifices must be aimed so that they discharge the steam across (perpendicular) to the airstream. Rotate the tubes as needed to accomplish this.

After tightening the 1/4-20 bolts at all 4 corners the ULTRA-SORB panel is ready for installation. See page 9.

Figure 8-2

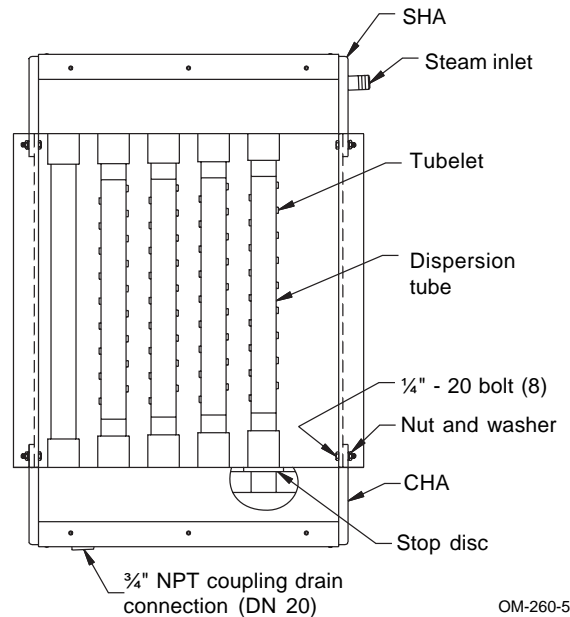

INSTALLATION

Selecting the Location

To put ULTRA-SORB® dispersion tube panels to work, you need to provide a steam supply and a method to remove condensate generated within the ULTRA-SORB panel.

When selecting the location, first consideration should be given to rapid, thorough absorption of the steam. The warmest air will most readily absorb the steam.

The distance that unabsorbed steam will travel within a given airstream is predictable and can be determined by referring to Table 19-1 on page 19.

A. It is very important that the **Field Assembly of ULTRA-SORB** panel be located where the water vapor being discharged will be absorbed by the airstream.

B. In general, the ULTRA-SORB panel should be placed where the air temperature is capable of absorbing steam being discharged without causing condensation at or after the unit. This will normally be downstream of the heating coil or where the air temperature is warmest.

C. Do not place in an outside air intake unless the air is tempered with a preheat coil.

D. Do not place the unit too near to the entrance of a high efficiency filter. The filter will remove the visible moisture and become waterlogged. See Note 4 on page 19 for absorption distance.

E. Do not place the ULTRA-SORB panel where discharged visible mist will impinge directly on a metal surface.

INSTALLATION

Placement of the Humidifier Within a System

Because of its rapid absorption characteristics the ULTRA-SORB® dispersion tube panel is the problem solver for previously troublesome humidification applications. The following comments are presented to assist the installer in judging the alternatives in some of the most common situations. The first rule is to choose the warmest part of the airstream.

Example 1: Placement in an Air Handling Unit

Location "A" is usually the first choice, assuming there are no "in duct" solid objects such as dampers or coils immediately downstream on which steam could condense.

Location "B" may be the next choice, assuming that steam absorption can be completed prior to entering the fan, otherwise the fan may be damaged by rusting.

Location "C" is a possibility. However, when and if the heating coil is cold, it will condense some of the humidifying vapor. In the absence of a drain pan or waterproof floor, this may not be acceptable. If the coil is *always* heated during the humidifying season, the warmer air decreases the absorption distance to better protect the fan.

Location "D" is a poorer location than "C" because the cooling coil will act as a moisture eliminator. Cooling coils have drain pans below them so water accumulation is not a danger. However, the condensed vapor represents a waste. Sometimes, even more important, is the fact that condensed steam can sometimes be very corrosive to the cooling coil. Minimal absorption distance requirements are shown in Table 19-1.

Location "E" would be an extremely poor choice because the air is cold and the filters would become saturated and/or covered with ice.

Figure 10-1

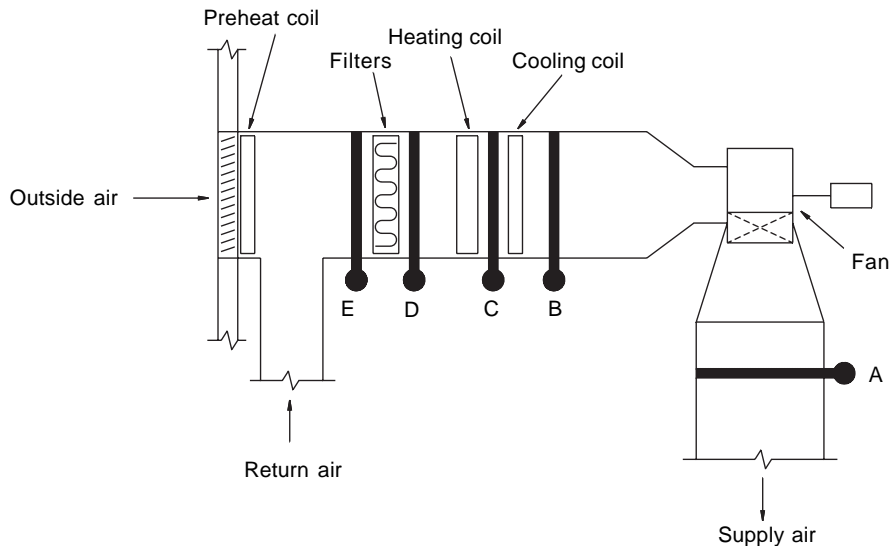

OM-196

Example 2: Installation in Cold Air Stream

When a humidifier is installed in a duct that will carry cold air periodically, the dew point temperature should be determined.

If the psychrometric chart reveals that saturation may occur, protection should be provided. A high limit humidistat or thermostat, set to cut off the humidifier at a safe temperature can be used for this purpose.

Figure 10-2

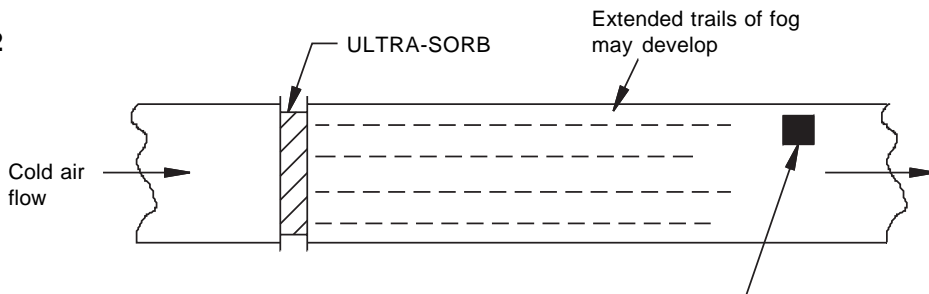

High limit duct humidistat to be mounted 10-15 feet downstream of ULTRA-SORB

OM-197

INSTALLATION

Figure 11-1

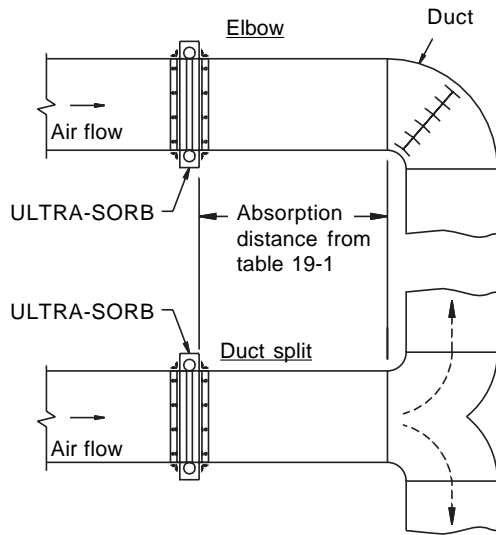

OM-178

Example 3: Placement Upstream of an Elbow or Duct Split

Due to the rapid steam absorption performance of the ULTRA-SORB® dispersion tube panel, these types of installations can be made with confidence. However, all mechanical equipment is subject to accidental failure. Therefore, if the installation is above expensive or irreplaceable objects a drip pan should be provided to prevent accidental spillage.

Figure 11-2

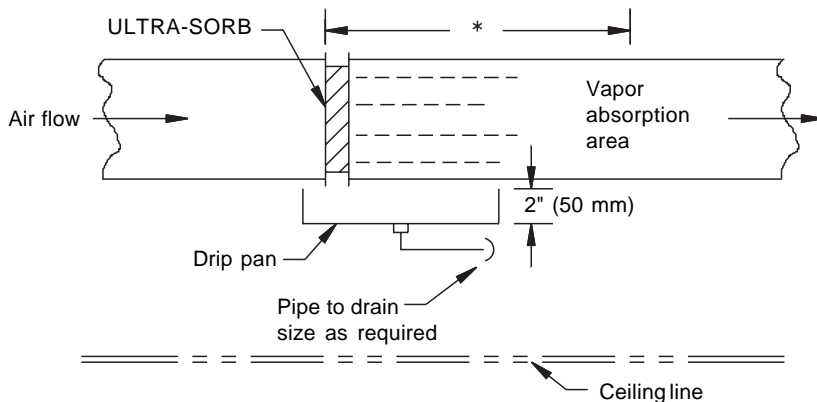

* The length of duct should have sealed seams. This dimension should be at least three times the height of the ULTRA-SORB.

OM-198

Example 4: Installation Above Valuable Equipment

Water piping and humidifiers preferably should not be installed above expensive apparatus or equipment. A broken water pipe, leaking valve gland, condensation or other accidental water spillage may occur causing serious damage and costly repairs to the equipment below.

When this type of installation cannot be avoided install a drip pan constructed of galvanized sheet steel under the humidifier, valve, etc. to catch and drain away the spill.

The condensate from the ULTRA-SORB panel should be piped as per piping diagrams and should not be discharged into the pan.

Figure 11-3

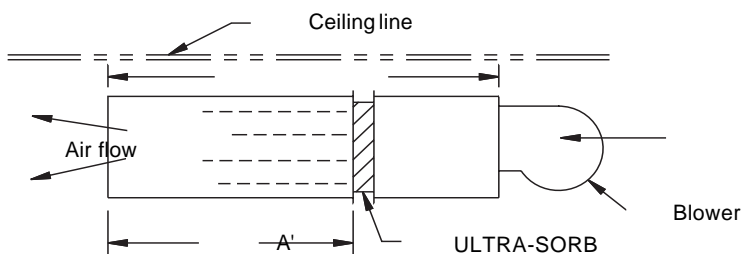

OM-179

Example 5: Recirculation Unit

In an application where no duct system exists, or if the duct air is too cool for proper humidity absorption, a recirculation fan can be used. The fan circulates room temperature air across the humidifier and discharges humidified air into the space. The point of air discharge should be carefully selected to avoid condensation on surfaces of the building or equipment.

INSTALLATION

Mounting ULTRA-SORB® in Duct Section

The ULTRA-SORB panel is contained within a mounting frame. A mounting flange 1-1/2" (38 mm) wide is provided on all four sides of the unit. The 1-1/2" (38 mm) wide portion of the header enclosure highlighted in the drawings below is intended to be a mounting flange. A matching flange or metal frame is required on the ductwork for connection to the ULTRA-SORB flanges. The recommended fastener is a #12 x 3/4 self drilling and tapping screw, spacing not to exceed 12" (305 mm). If an angle iron frame is provided on the duct section, a longer screw may be required. **Note: Screw penetration into header enclosure should not exceed 3/4" (20 mm) to avoid puncturing header.**

Plan View - Model LV

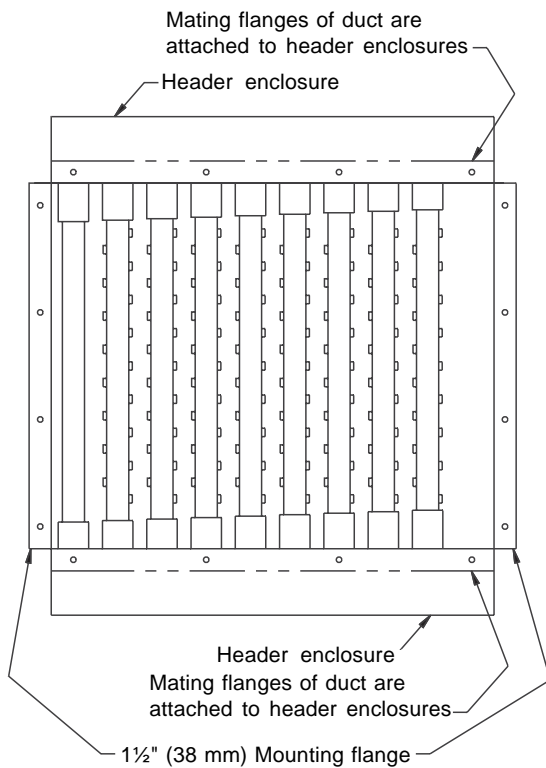

OM-203

Elevation View - Model LH

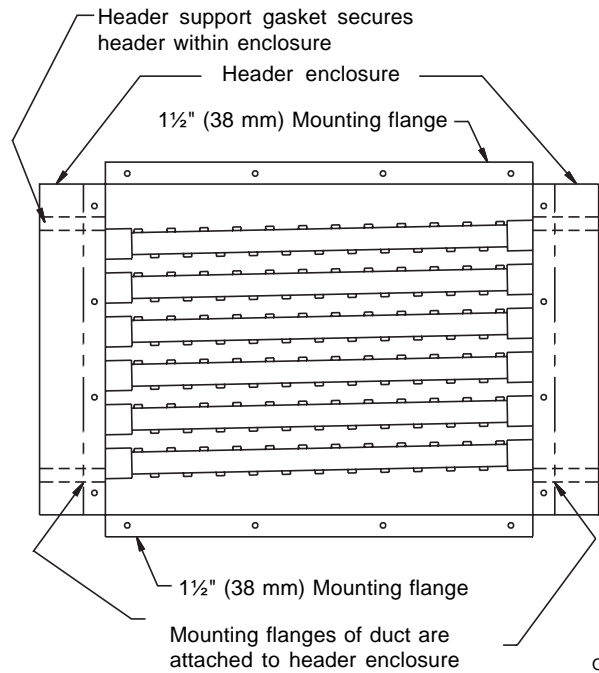

OM-177

Elevation

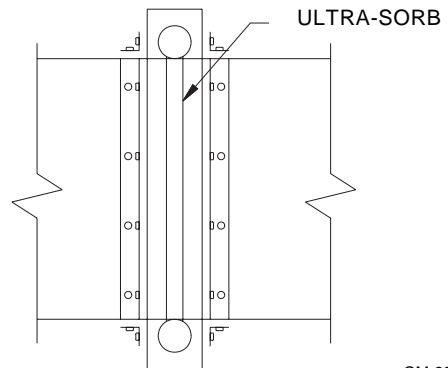

OM-234

INSTALLATION

Mounting ULTRA-SORB® in Vertical Duct Section

The ULTRA-SORB panel is contained within a mounting frame. A mounting flange 1-1/2" (38 mm) wide is provided on all four sides of the unit. The 1-1/2" (38 mm) wide portion of the header enclosure highlighted in the drawings below is intended to be a mounting flange. A matching flange or metal frame is required on the ductwork for connection to the ULTRA-SORB flanges. The recommended fastener is a #12 x 3/4 self drilling and tapping screw, spacing not to exceed 12" (305 mm). If an angle iron frame is provided on the duct section, a longer screw may be required. **Note: Screw penetration into header enclosure should not exceed 3/4" (20 mm) to avoid puncturing header.** Vertical airflow model must be ordered for this application. Headers and tubes are pitched accordingly to accommodate vertical mounting method.

Plan View - Model VAF

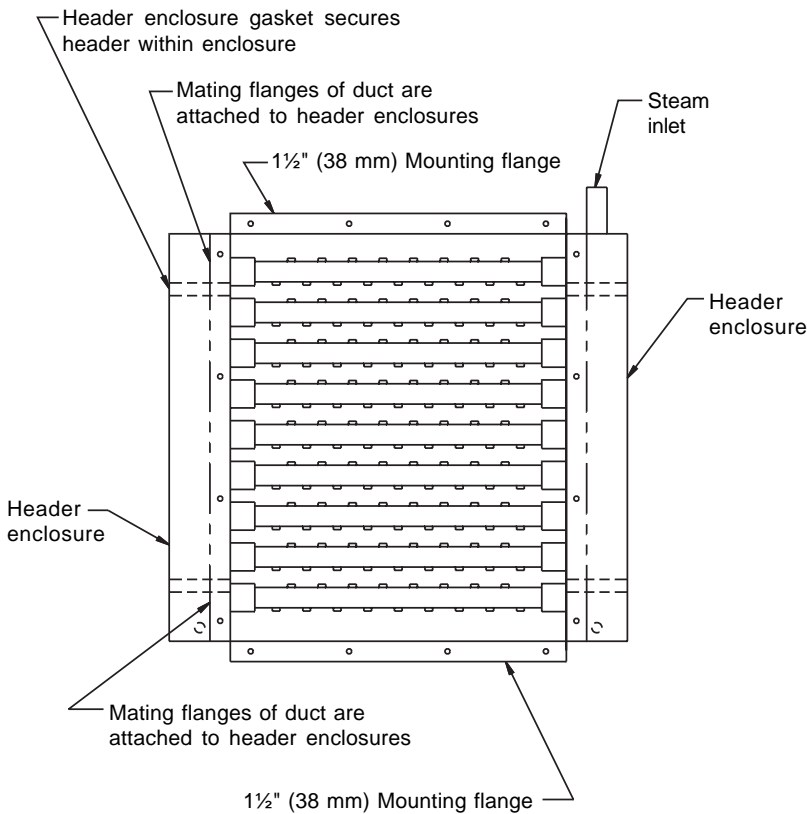

OM-203-A

Elevation View - Model VAF

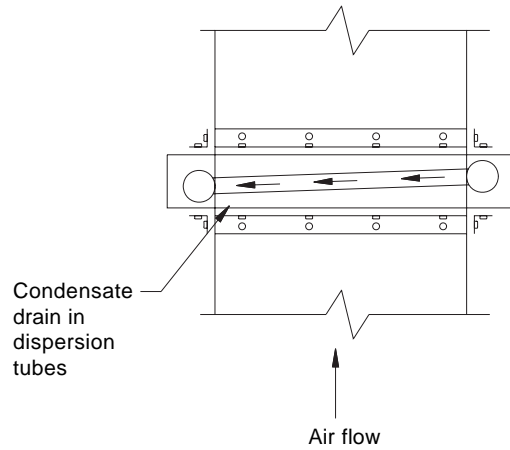

OM-234-A

Side View - Model VAF

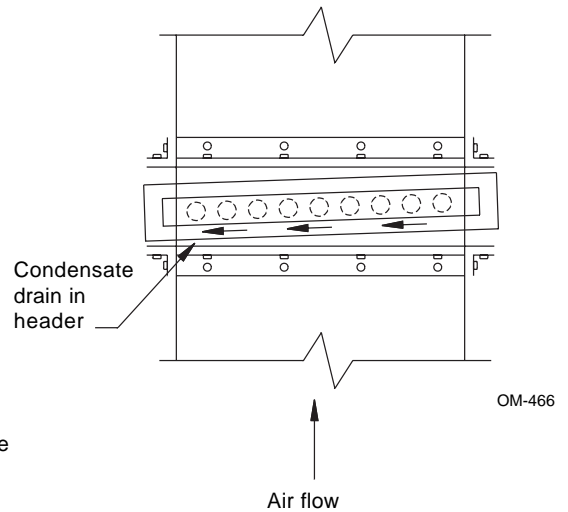

OM-466

INSTALLATION

ULTRA-SORB® Installation Inside An Air Handler

The preferred location for an ULTRA-SORB panel in an AHU is immediately downstream of a heating or cooling coil. When so mounted, uniform air flow across the face of the ULTRA-SORB is assured.

The metal support frame should be anchored to the air handler casing. Recommended fasteners for mounting the ULTRA-SORB to a metal support frame are ¼-20 nuts and bolts or #12 self drilling and tapping screws. Due to the possible forces exerted on this application, DRI-STEEM recommends fastener spacing not to exceed 6" (150 mm). On larger ULTRA-SORB installations, vertical channels may be required on both the inlet and outlet of the humidifier to provide proper support, shown by Figure A.

Figure A

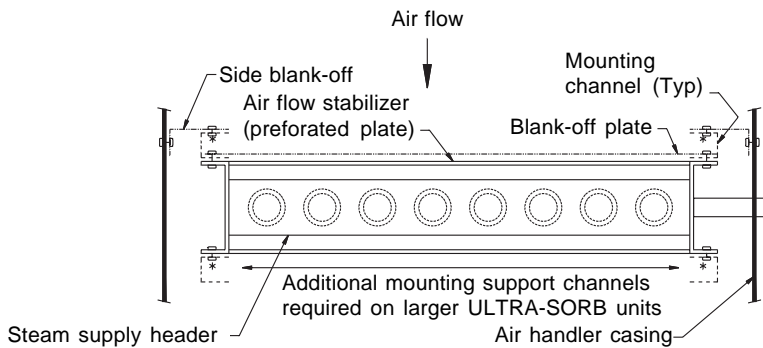

OM-199

Figure B

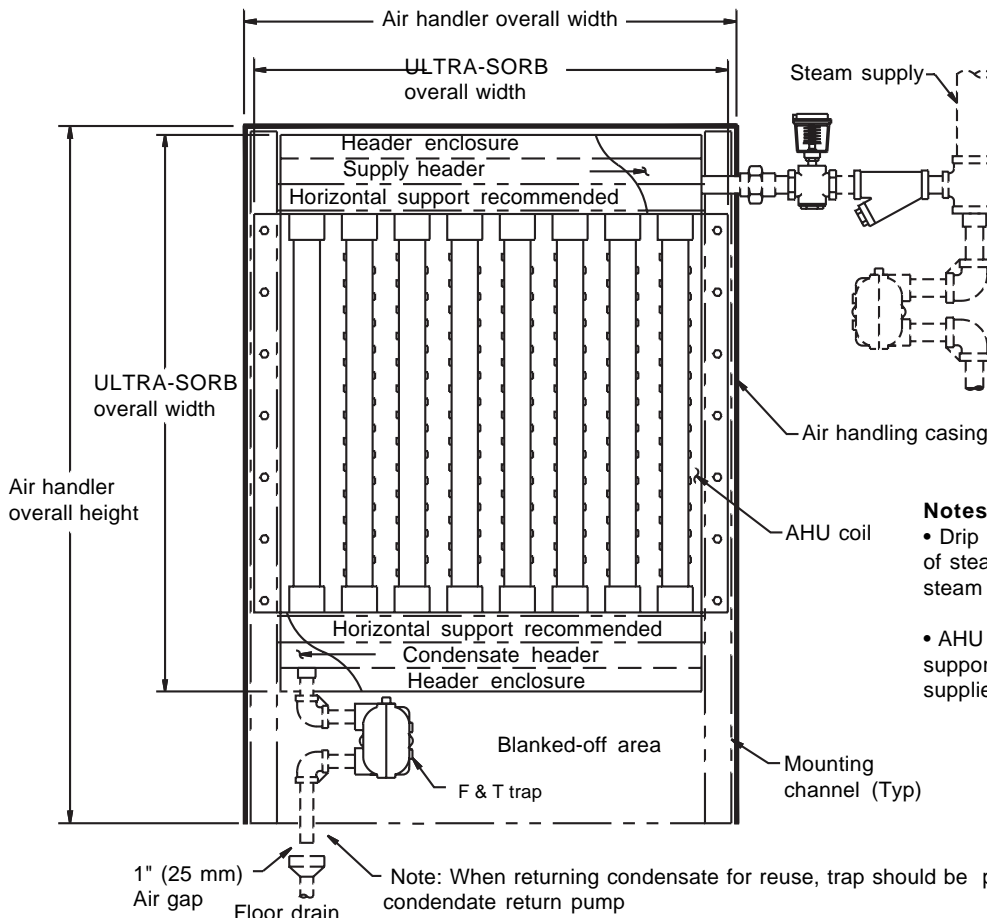

Notes:

- Drip steam supply ahead of steam valve through steam trap (as shown)
- AHU coil are mounting support channels not supplied by DRI-STEEM

Note: When returning condensate for reuse, trap should be piped to condensate return pump

OM-183

PIPING

When Supplying Steam From A Boiler

ULTRA-SORB® panels using boiler steam are provided with a NPT pipe nipple which extends outside the frame-work for steam supply connection. The steam supply line should be dripped immediately ahead of the steam valve through a steam trap.

Recommended Drip Trap Type:

Low pressure: Less than 15 psi - Float and Thermostatic

High pressure: More than 15 psi - Inverted Bucket

A wye strainer should be installed ahead of the steam valve.

Two 3/4" (20 mm) float and thermostatic traps, one for each header, are required on a horizontal dispersion tube (Model LH) ULTRA-SORB. One float and thermostatic trap is required on the lower header of the vertical tube (Model LV) ULTRA-SORB.

1. Humidifier steam supply should be taken off the top of the steam main (instead of side or bottom) to ensure driest steam.
2. Air flow proving switch is recommended to prevent steam valve from opening unless air is moving in duct.
3. High limit (duct mounted) humidistat 15 feet (4.5 m) or more downstream and set at 80-90% is recommended when duct air is below 70°F (21°C) to prevent over saturating duct airstream.
4. Steam discharge from dispersion tube tubelets must be pointed at right angles to airstream for best absorption results.

Model LH (Horizontal Dispersion Tubes)

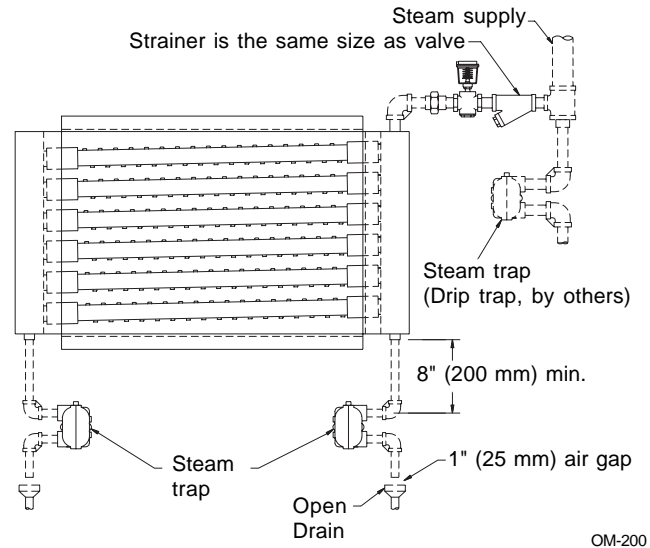

OM-200

Model LV (Vertical Dispersion Tubes)

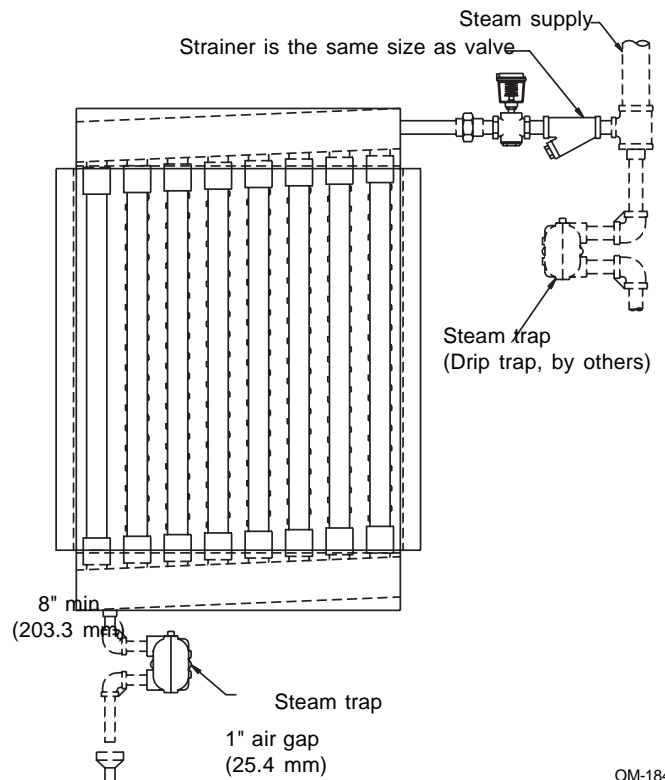

OM-184

PIPING

When Supplying Steam From An Evaporative Humidifier

Hard Pipe or Tubing

Standard steam hose connections on DRI-STEEM evaporative humidifiers are 1-1/2" (38 mm) stainless steel tubing. Two inch tubing connections are available as an option on the higher capacity evaporative units. Hose cuffs can be provided to connect hard pipe to the tubing connection on the vaporizing humidifier and to the ULTRA-SORB®, see Figure 16-2. If specified DRI-STEEM can also provide threaded connections on the vaporizing humidifier and on the ULTRA-SORB as indicated in Figure 16-3.

When non-threaded pipe is used, connections at both ends are completed with rubber vapor hose. Due to the difference in O.D. of pipe and tubing compared to I.D. of hose, multiple hose clamps may be required.

Vapor Hose

- Vapor hose must be supported to prevent sags or low spots and hose must be pitched a minimum of 2" (50 mm/m) per foot back to the humidifier.

Vapor Rigid Piping (when used)

- A minimum pitch of 2" (165 mm/m) per foot back to the humidifier should be maintained.
- 90° elbows are not recommended, two 45° elbows one foot apart are recommended instead. See Figure 16-2 and 16-3.

Failure to follow the above recommendation may result in excessive back pressures being imposed on the vaporizing humidifier. This in turn may lead to loss of water seal or leaking gaskets. When distance between the ULTRA-SORB and the vaporizing humidifier exceeds 20 feet (6 m), consult factory for special recommendations.

- Thin wall tubing will heat up with less start up heat loss than heavy wall pipe
- Insulating the tubing will reduce the loss in output caused by condensation in the tubing or piping

Table 16-1: Pipe Sizing

O.D. of Pipe and Tubing				
Nom. Dia.	Standard Pipe	Tubing Copper	Tubing SST	I.D. of Hose
1¼" (30 mm)	1.660	1.375	-	-
1½" (38 mm)	1.900	1.625	1.500	1.50
2" (50 mm)	2.375	2.125	2.000	2.00
2½" (65 mm)	2.875	2.625	3.00	3.00

Note: NPT x tubing adapters and flange x tubing adapters are available from DRI-STEEM.

Figure 16-1

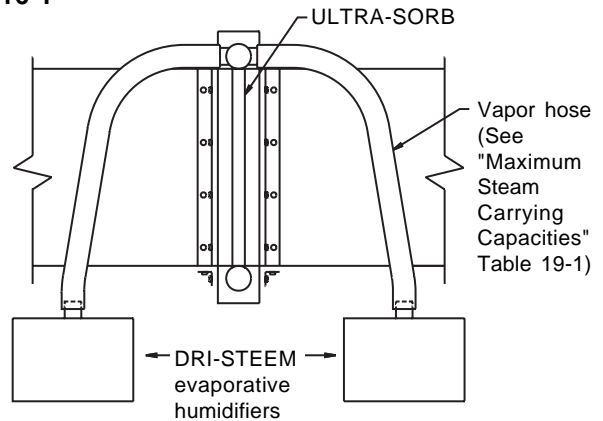

OM-155

Figure 16-2

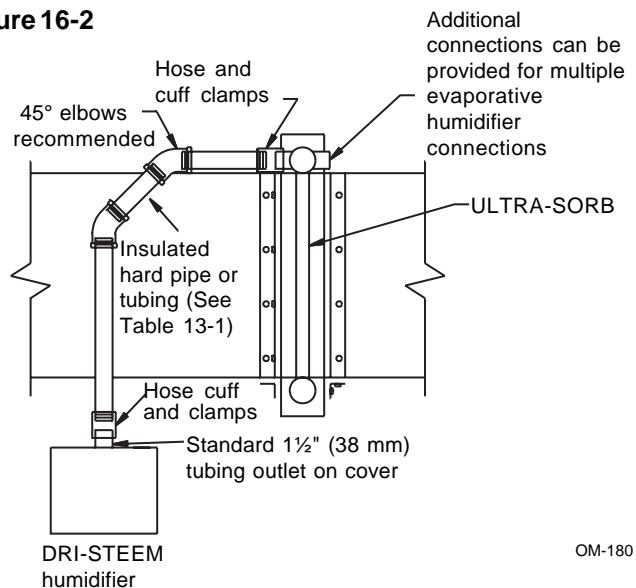

OM-180

Figure 16-3

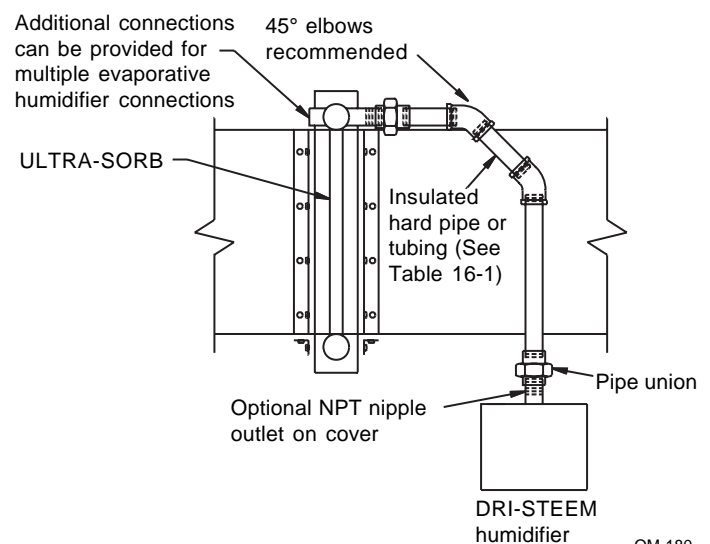

OM-180

PIPING

Condensate Drainage

Since ULTRA-SORB® operates with virtually zero internal pressure the condensate cannot be piped directly into a return main and should either be wasted to a floor drain or else piped into a small condensate pump, which, in turn, would return it to the steam source. In either case the drain connection of the ULTRA-SORB must be at an elevation that will permit gravity drainage.

To prevent steam from escaping from the drain line, either a steam trap (F&T trap) or a water seal can be provided in the drain line. The water seal must be of sufficient height to contain the pressure developed within the humidifier. This pressure is the sum of the flow resistance in the ULTRA-SORB and vapor hose (usually about 10" or 255 mm W.C.) plus the air static pressure of the duct system.

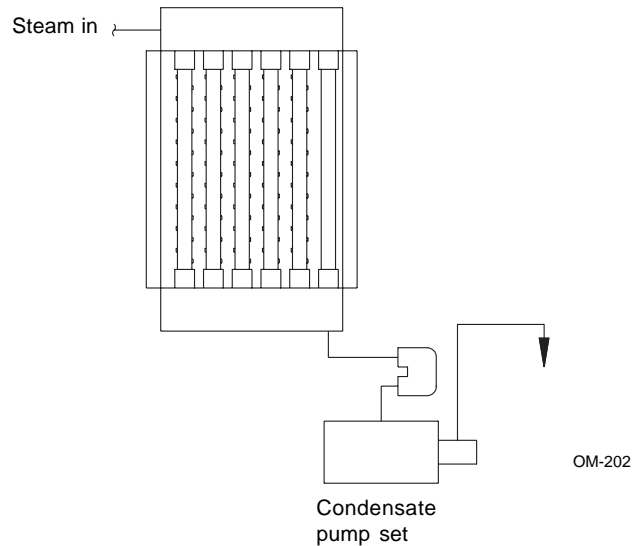
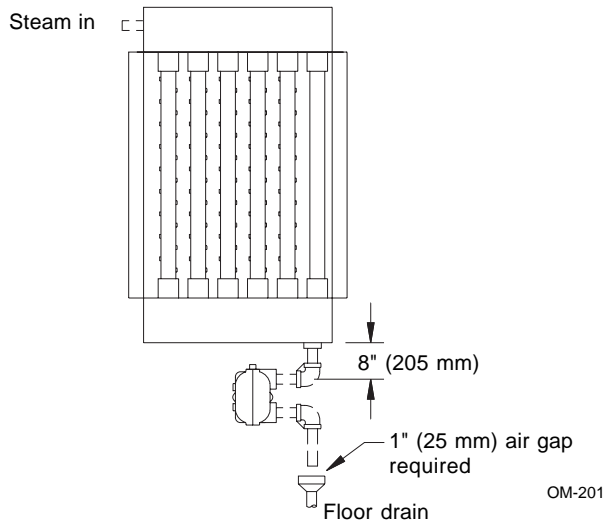
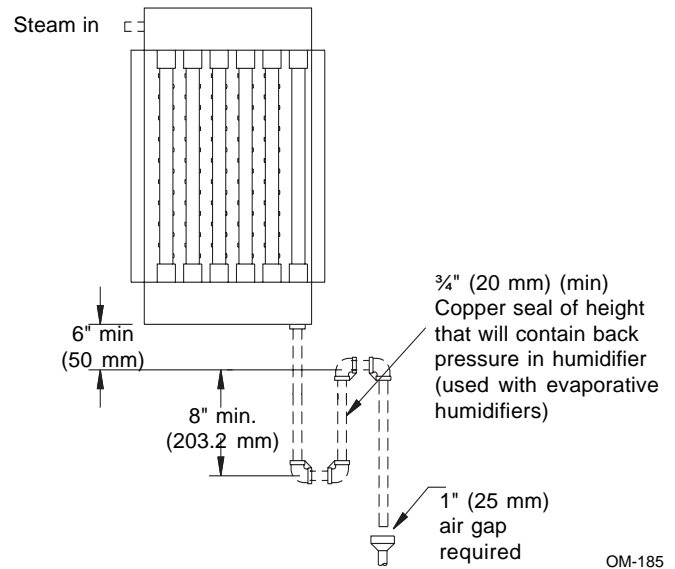

Table 17-1*: Maximum Steam Carrying Capacity in Lbs/Hr (Kg/Hr)

Vapor Hose			Copper or Stainless Steel Tubing and Schedule 40 Steel Pipe		
Hose I.D.	Developed Length of 10' (3.0 Meters)**		Tube or Pipe Size	Base on Developed Length of 20' (6 Meters)**	
1 1/2" (38 mm)	150 pph	68 kg	1 1/2" (38 mm)	150 pph	68 kg/h
2" (50 mm)	250 pph	115 kg	2" (50 mm)	220 pph	100 kg/h
			3" (75 mm)	450 pph	205 kg/h
			4" (100 mm)	750 pph	340 kg/h
			5" (125 mm)	1400 pph	635 kg/h
			6" (150 mm)	2300 pph	1043 kg/h

Notes:

* Based on total pressure drop in piping/hose of 5" (125 mm) W.C.

** For developed length add 50% to measured length for pipe fittings.

To minimize loss of humidifier capacity and efficiency, it is recommended that tubing/piping be insulated.

MOUNTING

The ULTRA-SORB® can operate with air flow in either direction however, the perforated plate, when required, must be on the air entering side of the ULTRA-SORB. To accommodate field conditions the perforated plate can be moved from one side of the ULTRA-SORB to the other. The steam supply must be connected to the top of the assembly, condensate must be removed from the bottom of the assembly.

Note: The perforated plate is supplied only with ULTRA-SORB panels installed in duct with face velocities less than 500 fpm (2.55 m/s). ULTRA-SORB installations in air handlers with coils do not require a perforated plate.

The duct section and ULTRA-SORB panel must be properly supported to carry the weight of the assembly. The weight of the piping must be supported by the building structure rather than by the ULTRA-SORB unit. Otherwise, the weight may impose stress on the connections, causing them to fracture and leak. Before start up, installer must verify that all steam discharge tubelets are pointed perpendicular to the airstream, see drawings at right. This can be accomplished by simply rotating the dispersion tubes. The O-ringed slip couplings provide easy adjustment for proper tubelet orientation.

When removing and reinstalling slip couplings verify that O-rings are seated in grooves and lubricated. Slide tube into coupling being careful not to cut the O-rings when inserting tubes.

Proper Dispersion Tube Orientation

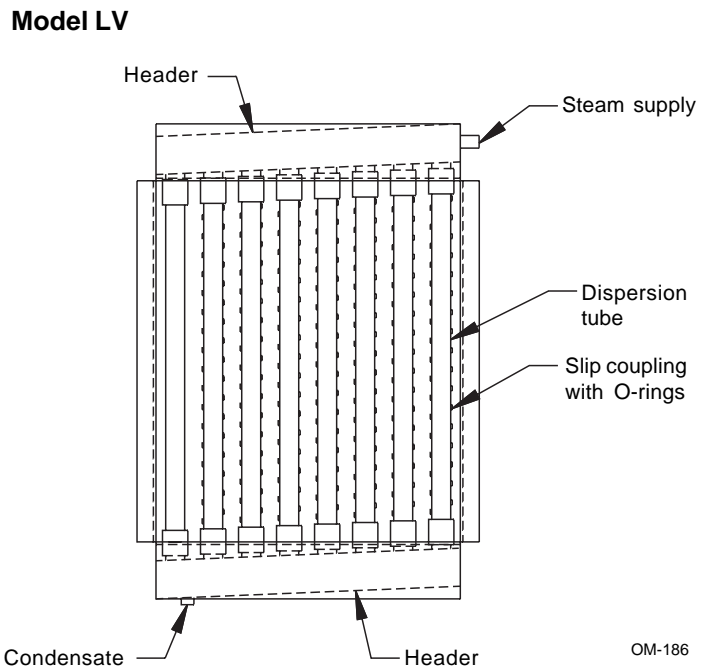
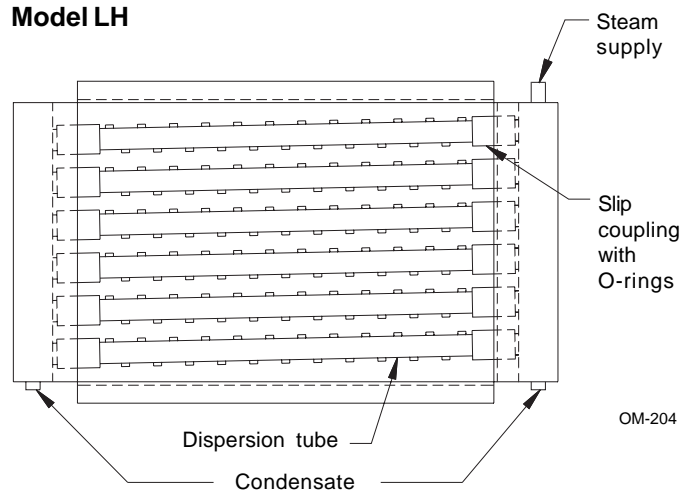
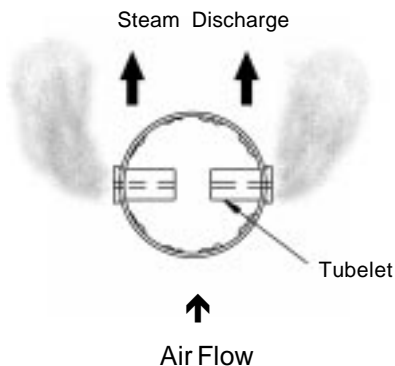

PERFORMANCE DATA

Table 19-1: ULTRA-SORB® Absorption/Non-Wetting Distances

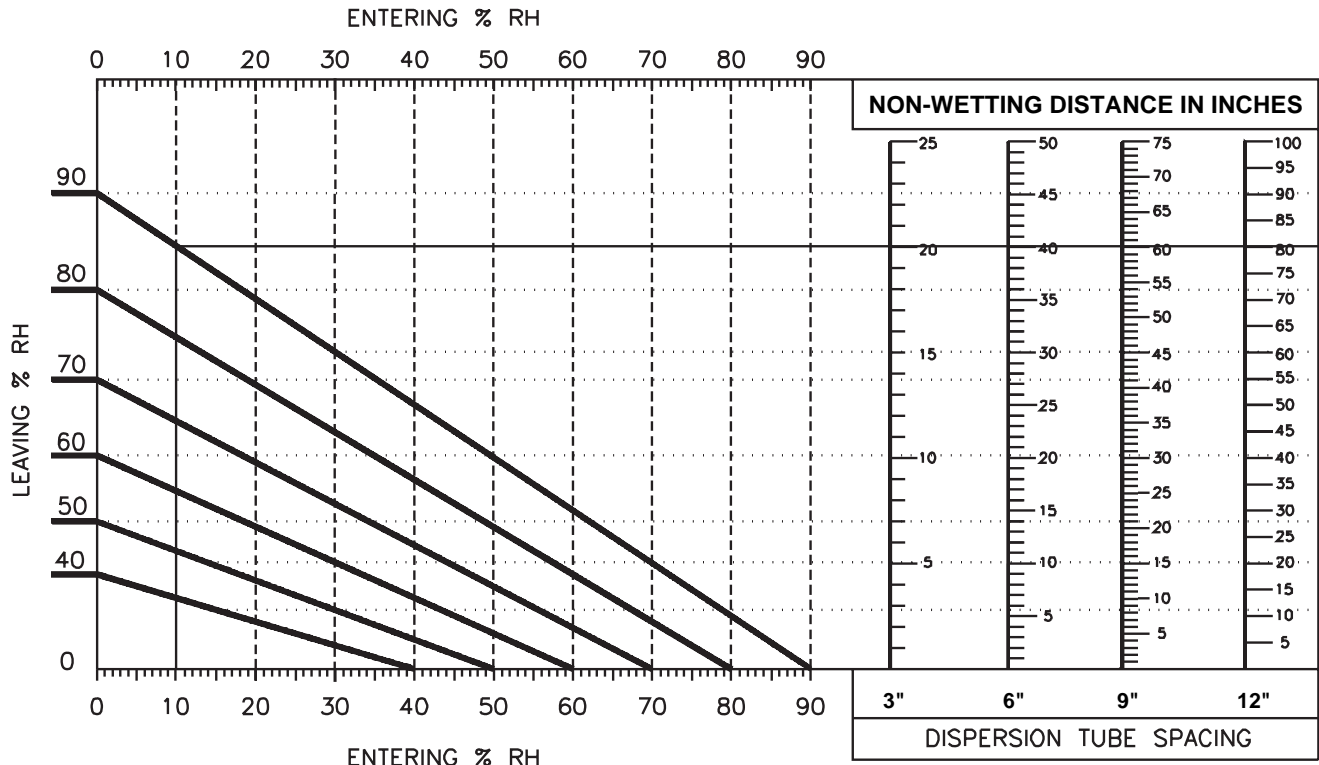

Note: The above absorption data applies to all air velocities up to 2000 fpm (10 m/s).

Formula 19-1: Mixed Air Inlet Lbs/100 cfm (kg/100 m³/h)

$$\% \text{ Outside Air} \times \text{Moisture Content} + \% \text{ Return Air} \times \text{Moisture Content} = \text{Mixed Air Inlet Lbs/100 cfm (kg/100 m}^3\text{/h)}$$

1. This performance data is based on air leaving the zone of humidification at conditions of 55°F (13°C) and stated % RH.
2. "Absorption or Non-wetting Distance" is the dimension downstream from the leaving side of the ULTRA-SORB panel to the point where condensed steam has been re- evaporated to the extent that wetting will not occur, although wisps may be present. Solid objects at duct air temperature such as coils, dampers, fans etc. downstream of this dimension will remain dry.
3. Note that the "rise" in RH (the difference between entering and leaving RH) has a direct bearing on the absorption distance. The greater the "rise" (the lower the entering RH for a given leaving RH) the greater the absorption distance.

4. **CAUTION:** When installing upstream of high efficiency filters, visible condensed steam wisps entering the filter bank can result in a wetted filter. If it is necessary to install an ULTRA-SORB in this manner, consult factory for recommendations.

5. To assure that absorption will take place, as stated in these guidelines, air duct design shall permit uniform air flow over the cross section of the ULTRA-SORB. Uneven air flow will result in non-uniform mixing of steam with air which, in turn, will adversely affect the absorption distance.

6. ULTRA-SORB air pressure loss in inches of water column.

	3" (75 mm) spacing	6" (150 mm) spacing
500 fpm (2.55 m/s)	.02" (0.5 mm)	.01" (0.3 mm)
1000 fpm (5.1 m/s)	.08" (2 mm)	.025" (0.6 mm)
1500 fpm (7.7 m/s)	.17" (4 mm)	.05" (1.3 mm)

Note: 9" (230 mm) and 12" (305 mm) spacing have no measurable air pressure loss.

REPLACEMENT PARTS

No.	Description	Qty.	Part No.
1	1-½" (38 mm) Dispersion Tube, LH		162730-tab
1	1-½" (38 mm) Dispersion Tube, LV		162732-tab
2	Tubelet .063		310160-001
2	Tubelet .078		310160-002
2	Tubelet .094		310160-003
3	Slip Coupling w/shoulder, 1-½" (38 mm)		310300
4	Slip Coupling w/o shoulder, 1-½" (38 mm)		310305
5	O-rings		300400-004
6	3" (75 mm) Dia. Supply Header - LH	1	per order
7	3" (75 mm) Dia. Condensate Header - LH	1	per order
8	3" (75 mm) Dia. Supply Header - LV	1	per order
9	3" (75 mm) Dia. Condensate Header - LV	1	per order
10	1-½" (38 mm) Dia. Condensate Drain Line	1	124435-tab
11	Air Flow Stabilizer	1	162760
12	F & T Trap		300000
13	Hose Cuff, 3" (75 mm) dia x 6" (150 mm) lg		305560-002
14	Hose Clamp Size		700690-002
15	Steam Valve	1	per order
16	½" (13 mm) y-strainer	1	300100-001
16	¾" (20 mm) y-strainer	1	300100-002
16	1" (25 mm) y-strainer	1	300100-003

No.	Description	Qty.	Part No.
16	1 - ½" (38 mm) y-strainer	1	300100-005
16	2" (50 mm) y-strainer	1	300100-006
16	2 - ½" (65 mm) y-strainer	1	300100-007
16	3" (75 mm) y-strainer	1	300100-008
17	Steam Connector	1	162765-tab
18	Mounting Flange, LH-LV	2	129600-tab
18	Mounting Flange, SH	2	129605-tab
19	Header Enclosure, LH	2	per order
19	Header Enclosure, LV	2	per order
19	Header Enclosure, SH	2	per order
20	Header Cover, LH-LV	2	129620-tab
20	Header Cover, SH	2	129625-tab
21	Cond. Header Cover, LV	1	129621-tab
22	Header Enclosure Cap, LH-LV		129630-tab
22	Header Enclosure Cap, SH		129635-tab

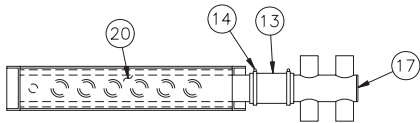

OM-205

Large Horizontal ULTRA-SORB

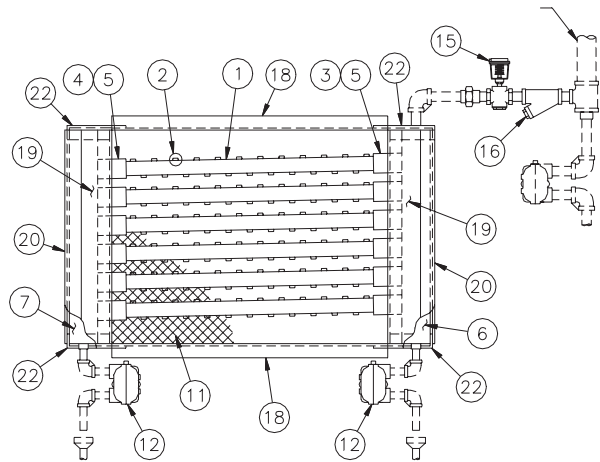

OM-206

Large Vertical ULTRA-SORB

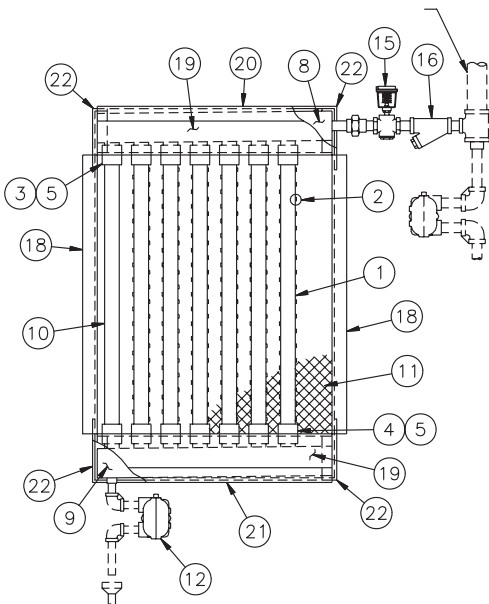

OM-207

Small Horizontal ULTRA-SORB

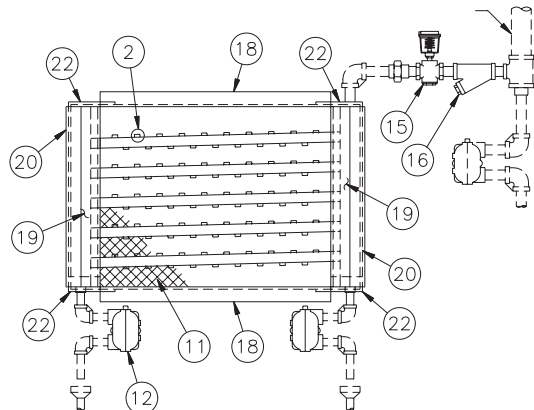

OM-187

TROUBLE SHOOTING GUIDE

PROBLEM	POSSIBLE CAUSE	RECOMMENDED ACTION
Humidifier Discharges Water in Duct	<ul style="list-style-type: none"> • Steam main overloaded with water due to boiler discharging water with steam (priming). • Steam trap not draining properly. • Humidifier improperly piped. • Surges of condensate in steam supply due to condensate collecting at low, undripped points in steam main. • Inadequate steam trap capacity. 	<ul style="list-style-type: none"> • Locate cause of priming and correct. • Replace trap or repair or clean as required. • If condensate return main is overloaded find an alternative method for drainage. • Correct the piping as shown in manual. Steam inlet should be at the top of the assembly and condensate outlet at the bottom of the assembly. • Install drips and steam traps as required. • Replace with larger trap.
Slip Couplings Leak Water	<ul style="list-style-type: none"> • Defective o-rings in slip couplings. 	<ul style="list-style-type: none"> • Replace o-rings.
Humidity Exceeds Setting of Humidistat	<ul style="list-style-type: none"> • Automatic valve not fully closing. • Control system malfunctioning due to: <ul style="list-style-type: none"> • Incorrect control voltage. • Incorrect control signal. • Improper wiring connections. • Incorrect humidity sensor (Siebe). • Humidity controller out of calibration. • Electric control system malfunctioning. • Faulty or inaccurate humidity controller. • Poor location of control components. • Incompatible control components. • Automatic valve is hunting. • Excessive outside air volume. 	<ul style="list-style-type: none"> • Foreign matter holding valve open, clean valve. • Valve spring broken, replace spring. • Valve stem packing adjusted too tightly, loosen and/or replace packing. • Steam pressure exceeds close off rating of valve spring, replace actuator or valve spring with one that is compatible with the higher steam pressure. • Valve installed backwards, remount. • Adjust valve linkage. • Replace transformer. • Replace components. • Rewire. • Replace. • Recalibrate. • Calibrate or replace. • Relocate per catalog recommendations. • Replace component(s). • Humidifier capacity is oversized, change to smaller valve. • Pressure reducing valve is not accurately controlling steam pressure, repair or replace. • Boiler pressure is swinging too widely, adjust. • Check fans, dampers, VAV, etc.

TROUBLE SHOOTING GUIDE

PROBLEM	POSSIBLE CAUSE	RECOMMENDED ACTION
Space Humidity Will Not Rise to Humidistat Set Point	<ul style="list-style-type: none"> • Steam pressure is too low. • Manual steam valve is partially closed. • Strainer screen is partially clogged. • Boiler pressure is too low. • Pressure reducing valve is not accurately controlling steam pressure. • Boiler pressure is swinging too widely. • Piped incorrectly. • Steam piping is undersized. • Humidifier is undersized. • Automatic steam valve is not opening fully. • Electric control system is malfunctioning. • Incorrect control circuit voltage. • Incorrect control signal. • Improperly wired. • Incorrect humidity sensor (Siebe units only). • Humidity controller out of calibration or malfunctioning. • Malfunctioning humidifier temperature switch not allowing humidifier valve to open. • Pneumatic control system malfunctioning. • Humidity controller out of calibration or malfunctioning. • Obstructed air line. • Malfunctioning pneumatic temperature switch. • Air leak in actuator. • Compressed air pressure is too low. 	<ul style="list-style-type: none"> • Open. • Clean. • Adjust control. • Repair or replace. • Adjust controls. • Repipe. • Replace. • Replace valve with larger capacity valve. • Replace with larger humidifier. • Add additional humidifier. • Valve packing is adjusted too tightly, loosen and /or replace packing. • Adjust valve linkage. • Recalibrate humidistat. • Change transformer. • Replace component(s) to make all components compatible. • Rewire. • Replace sensor. • Repair or replace. • Replace or readjust. • Repair or replace. • Remove obstruction. • Replace switch. • Repair or replace diaphragm. • Adjust pressure.
Condensate in Duct	<ul style="list-style-type: none"> • Foreign matter preventing valve from closing. • Humidifier is mounted too close to internal devices (dampers, turning vanes, etc.) in duct. • Non-insulated duct passing through unheated area (duct surface temperature too low). 	<ul style="list-style-type: none"> • Clean or replace valve. • Move humidifier tubes to a point further upstream of internal devices. • Add more dispersion tubes for shorter absorption distance. Consult DRI-STEEM Humidifier Company to determine the total number of tubes required. • Insulate ductwork.
Air Cannot Absorb Steam Quantity Being Discharged.	<ul style="list-style-type: none"> • Humidifier operates when blower is off. • Valve is "hunting". • Air temperature in duct is too low for steam quantity being emitted. 	<ul style="list-style-type: none"> • Provide interlock. • See previous page. • Raise temperature.
Humidifier is Noisy	<ul style="list-style-type: none"> • Steam pressure is too high. • Header is vibrating within header shell 	<ul style="list-style-type: none"> • Reduce pressure • Secure header - See details page 4

MAINTENANCE PROCEDURE

1. **STRAINER** - When the system is new the screen should be inspected at least twice during the first year. If found fouled, more frequent inspection and cleaning should be provided.
2. **STEAM TRAP** - At least twice a year verify that the steam trap is functioning properly. A blocked steam trap will be cold. A "blowing" steam trap will be hot and noisy and the discharge pipe from it will be hot for a continuous distance up to thirty feet. A properly operating steam trap will be hot and make noise at intervals and the discharge pipe from it will be progressively cooler beginning at the trap.
3. **VALVE (Pneumatic)** - Should be inspected annually to be sure that: 1. the valve closes off steam tight, 2. the stem packing is not leaking steam, and 3. the diaphragm in the actuator is not leaking air.
- VALVE (Electric Modulating)** - Should be inspected annually to be sure that the valve operates freely, closes off steam tight and that the stem packing is not leaking.
- VALVE (Solenoid Type)** - Inspect annually to verify proper functioning with steam tight shut off.
4. **O-RINGS - (Sliding Couplings)** - Inspect after two or three years of service, replace if necessary.

TWO-YEAR LIMITED WARRANTY

DRI-STEEM Humidifier Company ("DRI-STEEM") warrants to the original user that its products will be free from defects in materials and workmanship for a period of two (2) years after installation or twenty-seven (27) months from the date DRI-STEEM ships such product, whichever date is the earlier.

If any DRI-STEEM product is found to be defective in material or workmanship during the applicable warranty period, DRI-STEEM's entire liability, and the purchaser's sole and exclusive remedy, shall be the repair or replacement of the defective product, or the refund of the purchase price, at DRI-STEEM's election. DRI-STEEM shall not be liable for any costs or expenses, whether direct or indirect, associated with the installation, removal or reinstallation of any defective product.

DRI-STEEM's limited warranty shall not be effective or actionable unless there is compliance with all installation and operating instructions furnished by DRI-STEEM, or if the products have been modified or altered without the written consent of DRI-STEEM, or if such products have been subject to accident, misuse, mishandling, tampering, negligence or improper maintenance. Any warranty claim must be submitted to DRI-STEEM in writing within the stated warranty period.

DRI-STEEM's limited warranty is made in lieu of, and DRI-STEEM disclaims all other warranties, whether express or implied, including but not limited to any IMPLIED WARRANTY OF MERCHANTABILITY, ANY IMPLIED WARRANTY OF FITNESS FOR A PARTICULAR PURPOSE, any implied warranty arising out of a course of dealing or of performance, custom or usage of trade.

DRI-STEEM SHALL NOT, UNDER ANY CIRCUMSTANCES BE LIABLE FOR ANY DIRECT, INDIRECT, INCIDENTAL, SPECIAL OR CONSEQUENTIAL DAMAGES (INCLUDING, BUT NOT LIMITED TO, LOSS OF PROFITS, REVENUE OR BUSINESS) OR DAMAGE OR INJURY TO PERSONS OR PROPERTY IN ANY WAY RELATED TO THE MANUFACTURE OR THE USE OF ITS PRODUCTS. The exclusion applies regardless of whether such damages are sought based on breach of warranty, breach of contract, negligence, strict liability in tort, or any other legal theory, even if DRI-STEEM has notice of the possibility of such damages.

By purchasing DRI-STEEM's products, the purchaser agrees to the terms and conditions of this limited warranty.

DRI-STEEM[®]
HUMIDIFIER COMPANY



14949 Technology Drive • Eden Prairie, MN 55344
Phone: (612) 949-2415 • Fax: (612) 949-2933
E-Mail: sales@dristeem.com • Web: www.dristeem.com

Europe Office:

Bell Place, Bell Lane • Syresham, Brackley • NN13 5HP, U.K.
Phone: +44 1280 850122 • Fax: +44 1280 850124
E-Mail: 106277.1443@compuserve.com



Printed on recycled paper.
Minimum 10% Post Consumer Waste.

Continuous product improvement is a policy of DRI-STEEM Humidifier Company therefore, product features and specifications are subject to change without notice.

DRI-STEEM, RAPID-SORB, ULTRA-SORB are Registered Trademarks of the DRI-STEEM Humidifier Company.
TEFLON is a Registered Trademark of Dupont.