

# Steam Injection

## Humidification system

### Standard and CLEAN-STEEM™ models suitable for a wide range of applications

DRI-STEEM's Steam Injection humidifiers use steam from an external source, such as an in-house boiler or a district steam system. They are adaptable to virtually any size application, and a wide variety of models will accommodate a broad range of steam absorption requirements. All models shown in this catalog are available in either a standard configuration or as a CLEAN-STEEM model.

### CLEAN-STEEM humidifiers for controlled environments

Some humidification applications require steam that is completely devoid of impurities. For these applications, boiler steam is often derived from DI water and then dispersed into the air through one of our CLEAN-STEEM humidifiers.

CLEAN-STEEM humidifiers are typically used in environments with exacting temperature, air cleanliness and humidity requirements, such as hospitals, clean rooms, laboratories, and pharmaceutical plants.

With CLEAN-STEEM, a wide range of humidifier capacities, valve options and humidifier configurations are available. See the next page for a description of CLEAN-STEEM features, and individual Steam Injection model descriptions for capacities.

### Choose AREA-TYPE™ for ductless spaces

AREA-TYPE Steam Injection humidifiers are designed for open spaces such as warehouses and manufacturing spaces that may not have a duct system. The steam discharged from the humidifier is quietly dispersed by a fan without introducing water droplets into the air. For more information about AREA-TYPE humidifiers, see Pages 14-15.

### Quality construction from the industry leader

For more than 30 years, DRI-STEEM has been leading the industry with creative and reliable humidification solutions. Our focus on quality is evident in the construction of our Steam Injection models, which feature cleanable, stainless steel and an industry-leading, two-year warranty that covers all parts.



# Steam Injection features.

## Proven performance

- Stainless steel construction allows for instantaneous heat-up, which minimizes condensation and eliminates spitting on cold start-up.
- Stainless steel separator efficiently removes entrained water droplets and slugs of condensate using proven centrifugal design.
- Modulating steam control valves provide accurate control.
- A wide selection of valve kvs factors permits close matching of humidifier output capacity to actual job requirements, which eliminates valve hunting and results in precise control.
- Steam control valves are independent of separators, allowing easy removal for servicing and providing flexibility in choice of valve used.
- Special tube adaptor fittings (with two internal O-ring seals) permit valve removal without disassembling the humidifier piping.
- Lightweight construction simplifies installation; no special supports or hangers are required.

## Application flexibility

- Wide range of models and absorption distances meet virtually any humidification need.
- Steam is dispersed through ductwork or directly into a space.
- Adaptable to vertical as well as horizontal ducts
- Can be designed for use with DI water, for creating chemical-free steam (see CLEAN-STEEM™ features)

## Programmable control option

- Output is programmable for on-off or modulating control.
- Compatible with most building management systems; accepts all input signals
- Easy-to-use keypad interface displays current conditions and, in the unlikely event of an error, displays fault codes to reduce troubleshooting time.
- Cold-snap offset option prevents window condensation.
- VAV control option

## CLEAN-STEEM features

- The use of Series 304 stainless steel on all wetted parts reduces corrosion potential. When very pure DI steam is in use, 316 stainless steel is an available option. Passivation of humidifier weldments is an option also.
- Standard stainless steel valves are machined to precise tolerances and provide the highest rangeability in the industry. While a rangeability value of 40 to 1 is considered excellent, CLEAN-STEEM valves are capable of achieving up to 60 to 1.
- Steam valve options include electric, modulating, electric on-off, or pneumatic. The purchaser may also specify the valve manufacturer.

## Guaranteed absorption

- Steam-jacketed dispersion tubes are fitted with thermal-resin tubelets that have calibrated orifices to ensure uniform steam dispersion across the duct width.
- Thermal-resin tubelets have exceptional ability to trap noise generated by the valve, making the DRI-STEEM Steam Injection system the quietest in the industry.
- Cataloged and guaranteed steam absorption distances
- Published absorption tables for sizing and selecting the correct dispersion option
- DRI-STEEM's DRI-CALC® software is available for computer calculation of absorption distances and dispersion unit selection.

Features.

# Overview of models.

## Choose standard or CLEAN-STEEM™ configuration

All Steam Injection models, shown here, may be purchased in either a standard or a CLEAN-STEEM configuration.



### Single-Tube

- Suitable for small capacity systems
- Long absorption distance
- Pre-assembled



### MINI-BANK®

- Suitable for medium capacity systems
- Sized for small ducts
- Short to moderate absorption distance
- Pre-assembled



### Multiple-Tube or MAXI-BANK®

- Suitable for large capacity systems
- Range of sizes to fit small ducts to large air handlers
- Short to moderate absorption distance
- Multiple-Tube is field assembled (with interconnecting pipe supplied by contractor)
- MAXI-BANK is factory-assembled (and includes interconnecting piping)

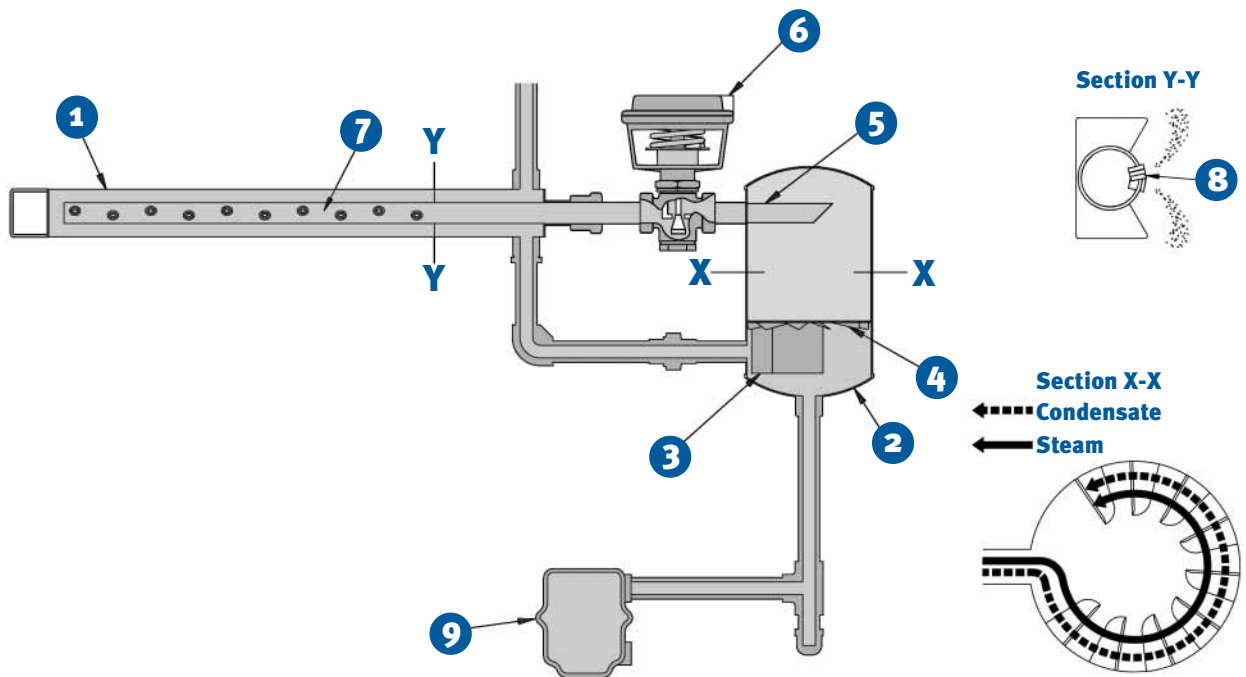


### AREA-TYPE™

- Suitable for medium capacity systems
- Used in ductless spaces
- Application-dependent absorption distances

*Steam Injection models.*

# Principle of operation.



1. Boiler steam with entrained water enters the humidifier at line pressure and flows through a chamber surrounding the inner dispersion tube, jacketing it with hot steam to eliminate condensation and dripping.
2. The steam with entrained water slows from entering the larger space of the separator and from hitting the perimeter deflector plate, and begins to spin and separate.
3. The separated steam rises through the slots of the multi-baffle plate to the upper region of the separator and enters the internal drying tube that excludes any remaining moisture particles, allowing only dry steam to leave the separator.
4. Separated condensate drains from the separator to the steam trap.
5. The steam valve controls the amount of steam allowed into the preheated dispersion tube. The steam valve is typically controlled in one of three ways:
  - Humidity controller connected to the steam valve
  - Control by another signal, such as a building management system
  - DRI-STEEM's VAPOR-LOGIC<sub>2</sub><sup>®</sup> microprocessor controller.
6. Steam is discharged uniformly through the tubelets into the airstream. Any condensate formed while passing through the steam valve is re-evaporated in the inner tube by the outer steam-heated jacket.

*How it works.*

# Single-Tube capacity.

**Table 5-1: Single-Tube maximum capacity (kg/h)**

Single tube capacity (kg/h)													
Model	Valve size	Valve Kvs	Supply steam pressure (kPa)										
			14	21	28	34	41	48	55	62	69	76	83
5-60	½"	0.09	0.8	0.9	1.0	1.1	1.3	1.4	1.5	1.5	1.6	1.7	1.8
5-60	½"	0.19	1.8	2.0	2.3	2.5	2.8	3.0	3.2	3.4	3.6	3.8	4.0
5-60	½"	0.3	2.9	3.6	4.2	4.7	5.1	5.5	5.9	6.3	6.6	6.9	7.2
5-60	½"	0.65	5.4	6.8	7.7	8.6	9.5	10.4	10.9	11.8	12.2	12.7	13.6
5-60	½"	1.1	9.5	11.8	13.2	15.0	16.3	17.7	18.6	20.0	20.9	21.8	22.7
5-60	½"	1.9	15.4	18.6	21.3	24.0	26.3	28.6	30.4	32.2	34.0	35.8	37.6
6-70	½"	2.81	22.7	28.1	31.8	36.3	39.5	43.1	45.8	49.0	51.7	54.4	56.7
6-70**	½"	3.1	25.4	30.4	35.4	39.5	43.5	47.2	50.3	54.0	56.7	59.9	63.0
6-70*	½"	3.8	29.9	36.7	42.2	47.2	52.2	56.7	61.2	64.9	68.5	71.7	75.3
7-70**	¾"	4.3	32.2	39.9	46.7	53.1	58.5	64.0	68.5	73.0	76.7	80.7	83.9
7-70*	¾"	4.8	35.4	43.1	50.3	57.2	63.5	68.9	73.5	78.0	82.6	86.6	91.2
7-70**	¾"	5.4	38.6	46.7	55.8	63.5	70.3	75.8	81.6	85.7	90.3	94.8	99.8
7-70*	¾"	6.5	43.5	54.9	64.4	73.0	80.7	85.7	92.5	98.4	103.9	108.4	113.9
7-70***	1"	8.2	50.3	64.0	73.9	84.4	92.1	99.8	107.5	112.5	119.3	126.1	131.5
7-70*	1"	8.7	53.1	67.6	76.2	85.3	98.0	102.5	109.3	117.0	122.5	129.3	136.1
7-70*	1"	10.4	57.2	70.3	81.6	91.6	101.6	111.1	119.7	126.6	134.7	141.1	147.9
8-80*	1¼"	17.3	132.0	158.3	183.7	197.8	213.6	233.1	250.4	265.8	281.7	298.0	312.5
8-80*	1½"	24.2	160.6	187.3	211.4	242.7	263.1	290.3	311.6	332.9	356.1	373.8	392.4

**Table 5-1: continued**

Single tube capacity (kg/h)												
Model	Valve size	Valve Kvs	Supply steam pressure (kPa)									
			90	97	103	138	172	207	†241	†276	†310	†345
5-60	½"	0.09	1.9	2.0	2.0	2.4	2.6	2.9	3.1	3.3	3.5	3.7
5-60	½"	0.19	4.2	4.3	4.5	5.2	5.8	6.3	6.8	7.2	7.7	8.2
5-60	½"	0.3	7.5	7.8	8.1	9.3	10.4	11.4	12.3	13.2	14.0	14.7
5-60	½"	0.65	14.1	14.5	15.0	17.2	19.5	21.3	23.1	24.5	26.3	27.7
5-60	½"	1.1	24.0	24.9	25.4	29.5	33.1	36.7	39.5	42.2	44.9	47.6
5-60	½"	1.9	39.0	40.8	42.2	48.5	54.9	60.3	65.8	70.8	74.8	79.4
6-70	½"	2.81	59.4	61.7	64.0	74.4	83.5	91.6	99.8	108.0	115.2	122.5
6-70**	½"	3.1	65.3	68.0	70.8	81.6	91.6	101.6	110.7	119.3	127.9	136.1
6-70*	½"	3.8	78.5	81.2	84.8	98.0	111.1	123.4	134.3	145.6	156.5	166.9
7-70**	¾"	4.3	87.5	91.6	94.3	110.2	124.7	138.8	152.4	165.1	177.8	190.1
7-70*	¾"	4.8	94.8	98.4	102.1	119.3	136.1	151.0	166.5	181.0	195.0	209.1
7-70**	¾"	5.4	104.3	108.9	112.9	132.0	150.1	168.3	185.5	201.9	218.6	235.4
7-70*	¾"	6.5	118.8	124.3	129.3	152.9	175.1	196.9	217.7	238.6	259.0	279.9
7-70***	1"	8.2	137.9	144.2	149.7	179.2	207.3	232.7	258.6	285.8	311.6	337.0
7-70*	1"	8.7	142.0	147.9	155.1	185.5	213.2	240.4	268.5	294.8	322.5	349.7
7-70*	1"	10.4	154.2	162.8	169.2	204.1	235.9	265.8	297.1	328.4	361.1	393.3
8-80*	1¼"	17.3	328.0	343.4	356.1	415.9	476.3	536.6	595.6	652.7	706.3	758.4
8-80*	1½"	24.2	410.1	424.6	443.6	542.5	633.7	719.4	802.9	887.7	968.9	1048.7

**Notes:**

\* Standard Steam Injection bronze valve only

\*\* CLEAN-STEEM™ stainless steel valve only

\*\*\* 1" 8.2 Kvs valve is a Baumann stainless steel valve

† Excessive valve wear may be experienced when supply steam pressure is more than 240 kPa.

Single-Tube.

# Single-Tube dimensions.

Figure 6-1: Single-Tube dimensions

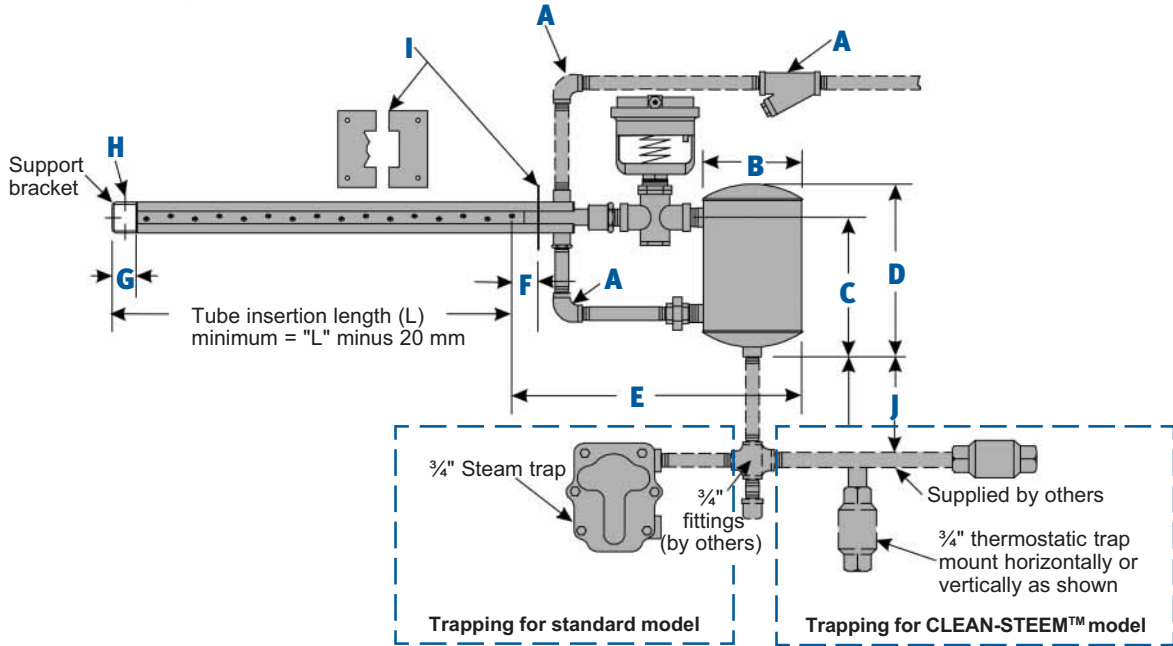


Table 6-1: Single-Tube dimensions

Model no.	Valve size	Dimension in millimeters									
								Dispersion tube			
		A	B	C*	D*	E	F	G	H	I	J (minimum)
5-60	1/2"	13	127	203	254	400	51	40	10	100x100	152
6-70	1/2"	19	152	210	267	400	51	40	10	100x100	152
7-70	3/4"	19	178	222	279	432	51	40	10	100x100	152
7-70	1"	19	178	222	279	432	51	40	10	100x100	152
8-80	1 1/2"	38	203	273	349	572	51	40	10	152x152	152
9-80	2"	38	229	279	362	667	40	40	10	152x152	152

**Notes:**

\*Variable 0-50 mm

Table 6-2: Standard dispersion tube insertion lengths (L) in millimeters

Standard dispersion tube lengths in millimeters																
Tube size	152	305	457	610	762	914	1219	1524	1829	2134	2438	2743	3048	3352	3658	
60	X	X	X	X	X	X	X	X	X	X	X	X	X	X	X	
70*			X	X	X	X	X	X	X	X	X	X	X	X	X	
80*				X	X	X	X	X	X	X	X	X	X	X	X	

**Notes:**

End support brackets are available only on tube lengths of 300 mm or longer.

\* Model 70 and 80 tubes are available in lengths up to 4875 mm in 305 mm increments.

Table 6-3: Shipping weights

Separator*					
Size	5	6	7	8	9
kg	8.6	9.5	10.9	19.5	23.5
Tube					
Tube no.	60	70	70	80	80
kg/m tube	.30	.50	.50	.70	.70

**Notes:**

\* Includes control valve, drain trap and strainer

Single-Tube.

# MINI-BANK<sup>®</sup> capacity.

## MINI-BANK humidifiers

The MINI-BANK humidifier is designed for use in small ducts. It is a pre-engineered and pre-assembled packaged unit, ready for mounting and hookup.

Slimline dispersion tubes with laboratory-tested, optimum tube spacing promote rapid steam absorption without excessive static pressure loss and heat gain.

With precision orifices of varying diameters spaced 25 mm on center, tubelets ensure proportional steam dispersion along the entire length of the tubes. Smaller diameter tubelets are inserted near the ends of the tubes to compensate for lower velocity airflow along the sides of the duct.



**Table 7-1: MINI-BANK maximum capacity**

MINI-BANK capacity kg/h														
kvs	Steam pressure in kPa													
	14	21	28	34	41	48	55	62	69	76	83	90	97	103
0.09	0.7	0.9	1.0	1.1	1.3	1.4	1.5	1.5	1.6	1.7	1.8	1.9	2.0	2.0
0.19	1.6	2.0	2.3	2.5	2.8	3.0	3.3	3.4	3.6	3.8	3.9	4.1	4.3	4.4
0.3	3.0	3.6	4.1	4.6	5.1	5.5	5.9	6.3	6.6	6.9	7.2	7.5	7.8	8.1
0.65	5.4	6.7	7.8	8.7	9.5	10.3	11.0	11.7	12.3	13.0	13.6	14.1	14.7	15.2
1.1	9.4	11.6	13.4	15.1	16.5	17.9	19.1	20.3	21.4	22.5	23.5	24.4	25.4	26.3
1.9	15.9	19.6	22.5	25.3	27.9	30.0	32.2	34.2	36.1	38.0				
2.81	23.0	28.6	32.9	37.1										
3.1	25.4	31.2	36.5											
3.8	30.3	38.1												

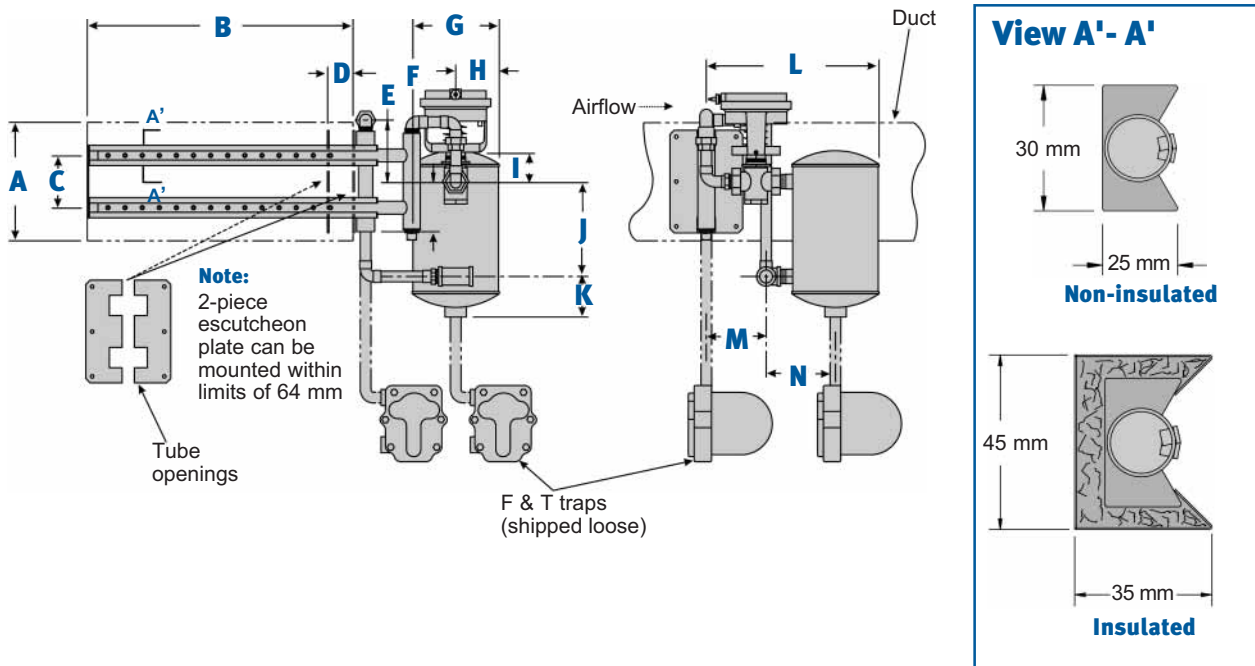
**Notes:**

\* At connection to humidifier  
A steam pressure of 35 to 70 kPa at inlet connection to separator is recommended for the most accurate control and quietest operation.

MINI-BANK.

# MINI-BANK® dimensions.

**Figure 8-1: MINI-BANK dimensions**



**Table 8-1: MINI-BANK specifications**

"A" duct height mm	Quantity of dispersion tubes required	"B" dispersion tube length	Shipping weights
150-230	2 tubes	From increments 150 to 660 mm in 50 mm increments, plus 1015, 1120, and 1220 mm. (For ducts larger than 610 x 1220 mm, use Multiple-Tube unit)	Calculate 0.4 kg per tube meter. Remainder (separator, valve, traps, etc.) weighs 3.8 kg.
250-305	3 tubes		
330-380	4 tubes		
405-460	5 tubes		
480-535	6 tubes		
560-610	7 tubes		

**Table 8-2: MINI-BANK dimensions**

	Dimensions											
	C	D	E	F	G	H	I	J	K	L	M	N
mm	76	38	89	79	127	64	45	140	64	267	89	102

**Table 8-3: MINI-BANK air pressure loss and heat gain**

Duct air velocity m/s	Static pressure loss Pa		Heat gain °C	
	Insulated	Non-insulated	Insulated	Non-insulated
2.5	10	5	1.0	2.0
3.8	17	10	0.9	1.8
5.1	32	19	0.8	1.6

MINI-BANK.

# Multiple-Tube/MAXI-BANK<sup>®</sup> capacity.

## Multiple-Tube/ MAXI-BANK Humidifiers

Multiple-Tube/MAXI-BANK humidifiers are best suited for large capacity systems able to accommodate a short to moderate absorption distance. They are designed to disperse steam evenly across an entire duct height and width.

The components of the Multiple-Tube humidifier are shipped loose for on-site assembly. All header and interconnecting piping is supplied by the contractor.

The MAXI-BANK humidifier is a multiple-tube humidifier that is factory assembled and shipped ready for installation. The MAXI-BANK features a stainless steel header and black steel interconnecting piping.



**Table 9-1: Multiple-Tube/MAXI-BANK maximum capacity (kg/h)**

Multiple-Tube capacity (kg/h)													
Sep Size	Valve Size	Valve Kvs	Supply steam pressure (kPa)										
			14	21	28	34	41	48	55	62	69	76	83
5"	½"	0.3	2.9	3.6	4.2	4.7	5.1	5.5	5.9	6.3	6.6	6.9	7.2
5"	½"	0.65	5.4	6.8	7.7	8.6	9.5	10.4	10.9	11.8	12.2	13.2	13.6
6"	½"	1.1	9.5	11.8	13.6	15.0	16.8	18.1	19.1	20.4	21.3	22.7	23.6
6"	½"	1.9	16.3	20.0	23.1	25.9	28.1	30.4	32.7	34.5	36.3	28.1	39.9
6"	½"	2.81	24.0	29.5	34.0	38.1	41.7	44.9	48.1	50.8	53.5	56.2	58.5
**6"	½"	3.1	26.8	32.7	37.6	42.2	45.8	49.9	53.1	56.2	59.4	62.1	64.9
*6"	½"	3.8	30.4	38.1	44.5	50.3	55.3	59.9	64.4	68.5	72.1	75.8	79.4
**7"	¾"	4.3	36.7	45.4	52.2	58.5	64.0	68.9	73.0	77.6	82.1	86.2	89.8
*7"	¾"	4.8	37.6	47.6	55.8	63.0	69.4	74.8	80.3	85.3	89.8	94.3	98.9
**7"	¾"	5.4	45.8	56.2	64.9	72.1	78.0	84.4	90.3	95.7	101.2	106.6	111.6
*7"	¾"	6.5	51.7	64.9	76.2	85.7	93.4	101.6	108.9	115.2	122.0	128.4	134.7
***7"	1"	8.2	65.3	82.1	94.3	106.1	116.6	126.6	136.5	145.2	154.2	161.9	170.1
*7"	1"	8.7	68.5	83.9	99.3	110.7	122.9	133.8	142.4	152.4	161.9	170.6	178.7
*7"	1"	10.4	82.6	100.7	116.6	132.9	144.7	158.3	171.0	182.8	194.1	204.6	214.6
*8"	1¼"	17.3	129.7	152.4	186.9	215.5	241.3	264.0	285.3	304.8	323.4	341.1	357.4
*8"	1½"	24.2	151.0	213.6	261.3	302.1	337.5	369.7	399.6	426.8	453.1	477.6	500.8
*9"	2"		215.5	304.8	373.8	431.4	482.2	528.4	570.6	610.1	646.8	682.2	715.3

**Table 9-1: continued**

Multiple-Tube capacity (kg/h)												
Sep. size	Valve size	Valve Kvs	Supply steam pressure (kPa)									
			90	97	103	138	172	207	241†	276†	310†	345†
5"	½"	0.3	7.5	7.8	8.1	9.3	10.4	11.4	12.3	13.2	14.0	14.7
5"	½"	0.65	14.1	14.5	15.0	17.7	19.5	21.3	23.1	24.9	26.3	27.7
6"	½"	1.1	24.5	25.4	26.3	30.4	34.0	37.2	39.9	43.1	45.4	48.1
6"	½"	1.9	41.3	43.1	44.5	51.3	57.6	63.0	68.0	73.0	77.6	81.6
6"	½"	2.81	61.2	63.5	65.8	76.2	85.3	93.4	101.6	108.4	115.7	122.0
**6"	½"	3.1	67.6	70.3	72.6	84.4	94.3	103.9	112.5	120.7	128.4	135.2
*6"	½"	3.8	82.6	85.7	88.9	103.0	115.7	127.0	137.4	148.3	157.4	166.0
**7"	¾"	4.3	93.9	97.5	101.2	117.5	132.0	145.2	157.4	168.3	178.7	188.7
*7"	¾"	4.8	103.0	107.0	111.1	128.8	145.2	159.7	172.8	185.1	196.9	207.7
**7"	¾"	5.4	116.1	120.7	125.2	145.6	163.7	180.1	195.0	208.7	221.8	264.1
*7"	¾"	6.5	140.6	145.6	151.5	176.4	198.2	217.7	235.9	252.7	268.1	283.0
***7"	1"	8.2	177.4	184.6	191.9	223.2	250.8	275.8	298.5	319.8	339.7	358.3
*7"	1"	8.7	186.9	194.6	201.9	235.0	264.0	290.3	314.3	336.6	357.4	377.4
*7"	1"	10.4	224.1	233.1	242.2	282.1	317.1	348.4	377.4	404.2	429.1	453.1
*8"	1¼"	17.3	373.8	388.7	403.7	469.9	528.4	580.6	628.7	673.6	715.3	754.8
*8"	1½"	24.2	523.0	544.3	564.7	658.2	739.8	812.8	880.4	943.0	1001.5	1056.9
*9"	2"		747.1	777.5	806.9	940.3	1056.4	1161.7	1257.4	1346.7	1430.6	1509.6

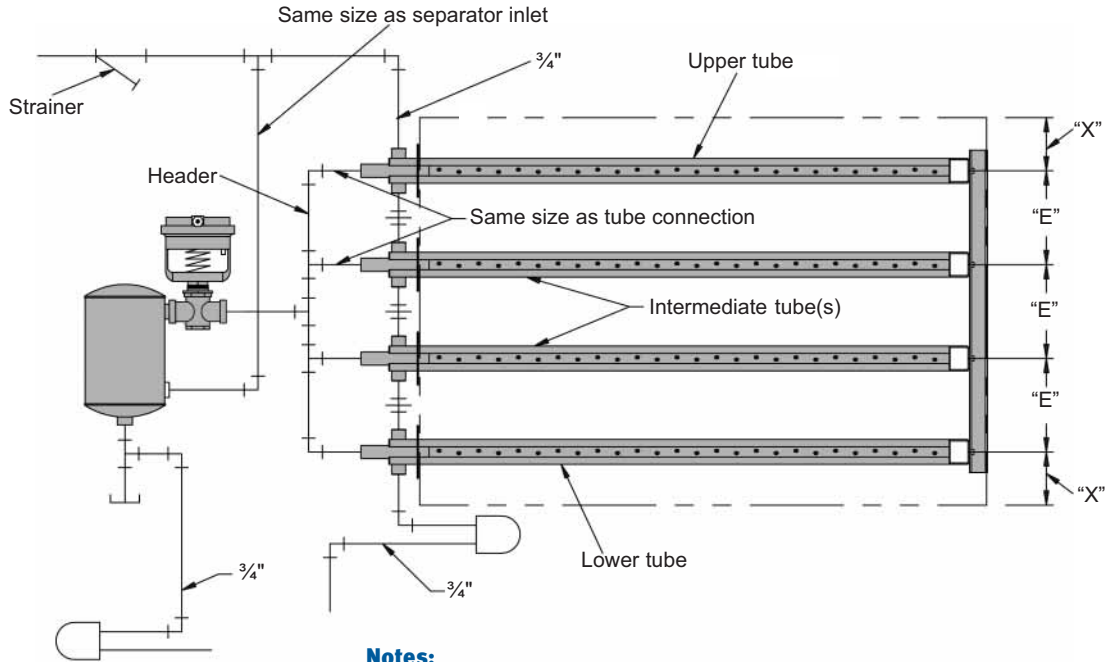
**Notes:**

- \* Standard Steam Injection bronze valve only
- \*\* CLEAN-STEEM stainless steel valve only
- \*\*\* 8.2 Kvs SST valve is not available in Siebe. Use Baumann or Warren valve.
- Valve manufacturer recommends not to exceed 240 kPa pressure drop across the SST valve. The table is based on 7 kPa back pressure on valve.

Multiple-Tube.

# Multiple-Tube/MAXI-BANK<sup>®</sup> dimensions.

**Figure 10-1:**



**Notes:**

Refer to Tables 9-1 and 10-1 for capacities. Refer to Tables 11-1, 11-2, 12-1, 12-2, and 13-3 for dimensions.

1. "X" shall not be greater than "E" dimension nor less than 1/2 "E."
2. Tubes should span at least 90% of coil or airstream width.
3. Steam should discharge against airstream.
4. If tubes are insulated, the dispersion tube will disperse with airflow.

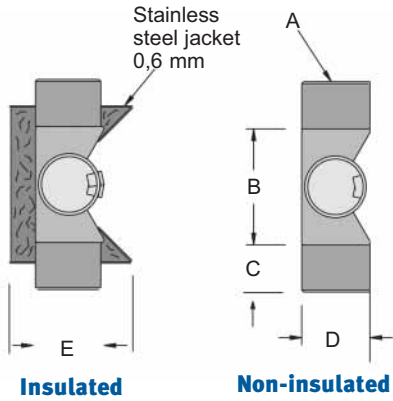
Multiple-Tube.

**Table 10-1: Dispersion tube capacity (kg/h)**

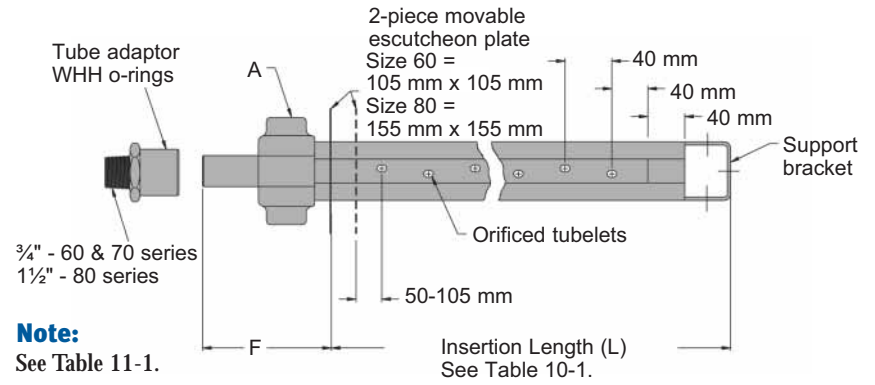
Tube length mm	60- & 70-series tubes	80-series tubes
610 to 890	81	159
915 to 1220	95	204
1220	113	238

# Multiple-Tube/MAXI-BANK® dimensions.

**Figure 11-1:**

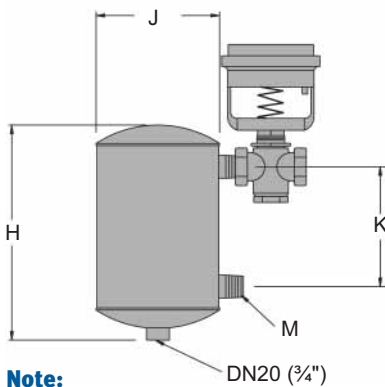


**Figure 11-2:**



**Note:**  
See Table 11-1.

**Figure 11-3:**



**Note:**  
See Table 11-2.

**Table 11-1: Multiple-Tube/MAXI-BANK dispersion tube dimensions in millimeters**

Tube No.	A	B	C	D	E	F
60	½"	48	21	29	51	102
70	¾"	67	21	48	76	102
80	1½"	76	27	64	89	140

**Table 11-2: Multiple-Tube/MAXI-BANK separator dimensions in millimeters**

Separator size	H	J	K	M	Shipping wt*
					kg
5	254	127	140	½"	8.6
6	267	152	137	¾"	9.5
7	280	178	140	¾"	10.9
8	343	203	175	1½"	19.5
9	368	229	178	2"	23.5

**Note:**  
\* Includes control valve, drain trap and strainer.

Multiple-Tube.

# Multiple-Tube/MAXI-BANK<sup>®</sup> dimensions.

**Table 12-1: Multiple-Tube/MAXI-BANK dispersion tube insertion length (L) in millimeters**

Tube no.	kg/m of tube	Multiple-Tube/MAXI-BANK dispersion tube insertion lengths in millimeters														
		152	305	457	610	762	914	1219	1524	1829	1829	2438	2743	3048	3353	3658
60	34	X	X	X	X	X	X	X	X	X	X	X	X	X	X	X
70*	45			X	X	X	X	X	X	X	X	X	X	X	X	X
80*	68				X	X	X	X	X	X	X	X	X	X	X	X

**Note:**

For lengths not shown, consult factory.

\* Model 80 tubes are available in lengths up to 4880 mm in 305 mm increments.

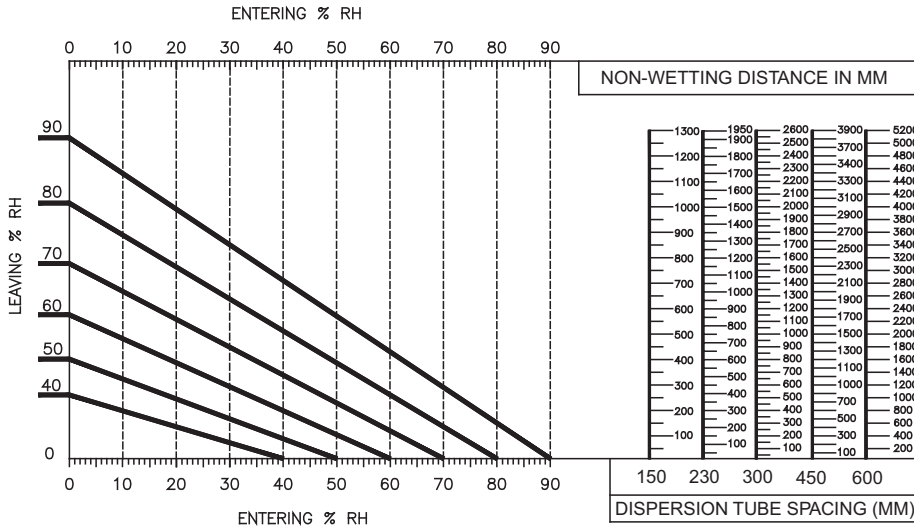
**Table 12-2: Multiple-Tube/MAXI-BANK strainer size in millimeters**

kPa	Strainer size kg/h						
	¾"	1"	1½"	2"	2½"	3"	4"
15	27	50	123	204	299	485	767
35	44	70	168	238	408	644	1157
70	54	86	204	345	499	817	1361
105	62	104	245	408	599	934	1633
140	73	118	283	522	703	1048	1860
170	82	136	327	544	780	1220	2141
205	91	154	358	612	907	1415	2495
240	100	163	390	658	998	1588	2858
235	111	181	436	735	1066	1678	2971
345	132	213	499	817	1134	1814	3221

Multiple-Tube.

# Multiple-Tube/MAXI-BANK<sup>®</sup> absorption.

**Figure 13-1: Multiple-Tube/MAXI-BANK absorption/non-wetting distances**



**Notes:**

- 150 mm minimum dispersion tube space with 60 series
- 180 mm minimum dispersion tube spacing with 70 series
- 230 mm minimum dispersion tube spacing with 80 series

**Table 13-2: Multiple-Tube bank air pressure loss and heat gain**

Tube centers mm	Duct air velocity m/s	Air pressure loss Pa		Heat gain in degrees °C	
		Insulated	Non-insulated	Insulated	Non-insulated
150	2.5	5	5	0.63	1.04
	5.1	20	15	0.46	0.86
	7.6	45	35	0.35	0.69
230	2.5	5	3	0.52	0.86
	5.1	15	12	0.40	0.69
	7.6	35	27	0.29	0.58
300	2.5	3	3	0.40	0.75
	5.1	10	10	0.35	0.58
	7.6	25	20	0.28	0.50
450	2.5	3	3	0.40	0.63
	5.1	8	8	0.35	0.52
	7.6	17	17	0.27	0.47
600	2.5	3	3	0.28	0.48
	5.1	8	8	0.24	0.37
	7.6	17	17	0.20	0.34

**Table 13-3: Multiple-Tube/MAXI-BANK header sizing**

Total capacity kg/h	Header Ø mm
Up to 127	40
128 to 222	50
223 to 445	80
446 to 790	100
791 to 1248	125
1249 to 1809	150

Multiple-Tube.

# AREA-TYPE™ capacity.

## AREA-TYPE humidifier

The AREA-TYPE humidifier is designed for open spaces, such as warehouses and manufacturing spaces, that may not have a duct system. The steam discharged from the humidifier is dispersed by the fan. The AREA-TYPE humidifier quietly distributes steam without introducing water into the air.

## Application note

Steam discharged from the humidifier turns into a fog that is lighter than air. Should this fog contact any solid surface before it is absorbed, it may collect as water and drip.



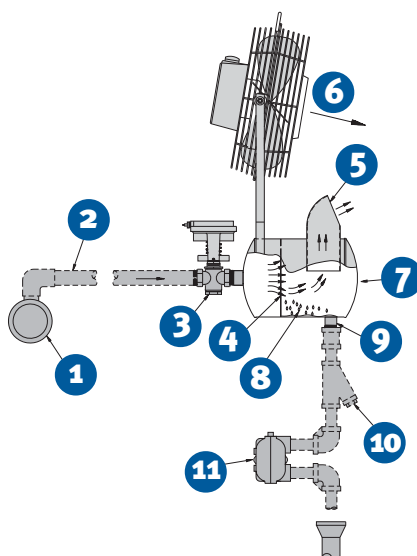
**Table 14-1: AREA-TYPE maximum capacity**

Valve size	Valve Kvs	Steam pressure kPa													
		14	21	28	34	41	48	55	62	69	76	83	90	97	103
½"	0.3	2.9	3.6	4.2	4.7	5.1	5.5	5.9	6.3	6.6	6.9	7.2	7.8	7.8	8.1
	0.65	5.4	6.8	7.7	8.6	9.5	10.4	10.9	11.8	12.2	13.2	13.6	14.1	14.5	15.0
	1.1	9.5	11.8	13.6	15.0	16.8	18.1	19.1	20.4	21.3	22.7	23.6	24.5	25.4	26.3
	1.9	16.3	20.0	23.1	25.9	28.1	30.4	32.7	34.5	36.3	38.1	39.9	41.3	43.1	44.5
	2.81	24.0	29.5	34.0	38.1	41.7	44.9	48.1	50.8	53.5	56.2	58.5	61.2	63.5	65.8
	3.8	32.7	39.9	45.8	51.3	56.2	60.8	64.9	68.9	72.6	76.2	79.4	82.6	85.7	88.9
¾"	4.8	40.4	49.9	57.6	64.0	70.3	75.8	81.2	86.2	90.7	95.3*	219* (99.3)*	103.4*	107.5	111.1*
	6.5	55.3	67.6	78.5	87.5	95.7*	103.9*	110.7*	117.5*	123.4*	129.7*				
1"	8.7	73.9	90.3	104.3*	116.6*	127.9*									
	10.4	88.5	108.4*	125.2*											

\* Sound level greater than 95 db.

AREA-TYPE.

**Figure 14-1: AREA-TYPE**

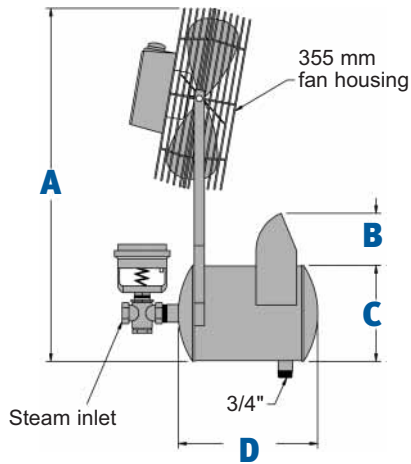


**Table 14-2: AREA-TYPE components**

No.	Description
1	Steam main
2	Steam run-out
3	Steam valve
4	Internal baffle plate
5	Steam dispersion port
6	3-speed fan
7	Separator
8	Entrained condensate
9	Humidifier separator drain 3/4"
10	Strainer
11	F & T trap

# AREA-TYPE™ dimensions/absorption.

**Figure 15-1: Dimensions**



**Table 15-1: AREA-TYPE dimensions**

Area-Type dimensions				
	A	B	C	D
mm	700	120	180	240

**Table 15-2: AREA-TYPE minimum distances for rise, spread and throw**

Capacity	16° C Space Temperature								
	30% RH			40% RH			50% RH		
	Rise	Spread	Throw	Rise	Spread	Throw	Rise	Spread	Throw
20 kg/h	0.5 m	1.0 m	2.0 m	0.5 m	1.0 m	2.0 m	0.5 m	1.0 m	2.0 m
45 kg/h	1.5 m	1.5 m	3.0 m	1.5 m	1.5 m	3.0 m	1.5 m	2.0 m	3.0 m
65 kg/h	2.0 m	2.0 m	4.0 m	2.0 m	2.0 m	4.0 m	2.0 m	2.0 m	4.0 m
90 kg/h	2.5 m	2.5 m	4.0 m	2.5 m	2.5 m	4.5 m	2.5 m	2.5 m	4.5 m
110 kg/h	2.5 m	2.5 m	5.0 m	3.0 m	3.0 m	5.0 m	3.0 m	3.0 m	5.0 m
130 kg/h	3.0 m	3.0 m	5.5 m	3.0 m	3.0 m	5.5 m	3.0 m	3.0 m	5.5 m

**Table 15-2: continued**

Capacity	21° C Space Temperature								
	30% RH			40% RH			50% RH		
	Rise	Spread	Throw	Rise	Spread	Throw	Rise	Spread	Throw
20 kg/h	0.5 m	0.5 m	1.5 m	0.5 m	1.0 m	1.5 m	0.5 m	1.0 m	1.5 m
45 kg/h	1.0 m	1.0 m	2.5 m	1.0 m	1.0 m	2.5 m	1.0 m	1.0 m	2.5 m
65 kg/h	1.5 m	1.5 m	3.0 m	1.5 m	1.5 m	3.5 m	1.5 m	1.5 m	3.5 m
90 kg/h	2.0 m	2.0 m	3.5 m	2.0 m	2.0 m	4.0 m	2.0 m	2.0 m	4.0 m
110 kg/h	2.0 m	2.0 m	4.0 m	2.0 m	2.0 m	4.0 m	2.0 m	2.0 m	4.5 m
130 kg/h	2.5 m	2.5 m	4.5 m	2.5 m	2.5 m	5.0 m	2.5 m	2.5 m	5.0 m

AREA-TYPE.

# Expert help makes it easy.



*DRI-CALC* computer software can help you size and select the right DRI-STEEM product for your particular application.

## Ask a distributor

Many years of hands-on experience have made DRI-STEEM sales distributors humidification experts. Supported by a strong force of DRI-STEEM application specialists, they are available to assist with any humidification need.

## Read our Humidification Handbook

Read this handbook for everything you've ever wanted to know about humidification. It contains more than 150 pages of technical information written in a very readable style. The handbook covers process requirements, RH control suggestions, design of systems, load sizing, use of the psychrometric chart, various humidifier types, and installation recommendations.

## See the video

Ask your distributor for our short video describing humidification essentials, indoor air quality (IAQ) issues, and DRI-STEEM's humidification systems.

## Or let your computer figure it out

DRI-STEEM's exclusive software, DRI-CALC<sup>®</sup> is a user-friendly software program designed to save engineering time. The software sizes loads, selects equipment, writes specifications, and creates equipment schedules for DRI-STEEM products. It also includes drawings of products and an encyclopedia of humidification terms.

## Industry-leading warranty

DRI-STEEM guarantees its products will be free from defects in materials and workmanship for a period of 27 months from product ship date.

# **DRI-STEEM<sup>®</sup>**

14949 Technology Drive • Eden Prairie, MN 55344  
Phone: (800) 328-4447 • (952) 949-2415 • Fax: (952) 229-3200  
E-Mail: sales@dristeem.com • Web: www.dristeem.com

### Europe office:

Marc Briers, Grote Hellekensstraat 54 b, B-3520 Zonhoven, Belgium  
Phone: +3211823595  
Fax: +3211817948  
E-Mail: marc.briers@dristeem.com

Continuous product improvement is a policy of DRI-STEEM Humidifier Company. Therefore, product features and specifications are subject to change without notice.

DRI-STEEM, CLEAN-STEEM, MINI-BANK, MAXI-BANK, VAPOR-LOGIC<sup>2</sup> and DRI-CALC, are Registered Trademarks of the DRI-STEEM Humidifier Company.

Your DRI-STEEM distributor is: