

High-Pressure Atomizing System

Installation, Operation,
and Maintenance Manual

DRISTEEM[®]
The humidification experts



Warnings and cautions



WARNING



Disconnect electrical power



Disconnect electrical power before installing supply wiring or performing service or maintenance procedures on any part of the humidification system. Failure to disconnect electrical power could result in fire, electrical shock, and other hazardous conditions. These hazardous conditions could cause property damage, personal injury, or death.



CAUTION

Operate humidification system at above-freezing temperatures.

Operating the humidification system at temperatures below freezing can damage the humidification system or cause other property damage.

Maintain pumping equipment.

Inadequately maintained pumping equipment can cause the humidification system to fail. Drain and replace the oil supply of oil-lubricated pumps after the first 50 hours of use, and then after every 500 hours of use. Drain and replace the oil supply if the pumping equipment has not been used for more than one year.

Maintain water pH level at 5.0 or more.

Water with a pH level less than 5.0 can damage the humidification system and void your warranty. Test supply water regularly to ensure water pH level is 5.0 or more.

Do not install the humidification system using steel or galvanized-steel joints.

Steel and steel-galvanized joints can corrode and cause system damage. Use stainless steel joints when assembling system.

Follow all instructions in this manual to maintain product warranty.

Table of contents

| | |
|--|----------|
| Warnings and cautions | 2 |
| Overview | 6 |
| System overview | 6 |
| System dimensions | 7 |
| Components overview | 8 |
| Dechlorinator | 9 |
| Pumping station | 11 |
| Purified water reserve tank | 13 |
| Atomizing nozzles | 14 |
| Mist eliminator | 15 |
| Control transmitters and switches | 15 |
| Installation | |
| Components and tools needed | 16 |
| Placing components | 17 |
| Clearances | 17 |
| Dechlorinator (floor mounted only) | 18 |
| Duplex water softener | 18 |
| Brine tank | 18 |
| Pumping station | 19 |
| Purified water reserve tank | 19 |
| Dispersion piping and manifolds | 19 |
| Atomizing nozzles | 20 |
| Temperature/humidity and airflow sensors | 21 |
| Solenoid valves | 21 |
| Water supply line pressure gauge | 22 |
| Dechlorinator | 22 |
| Duplex water softener | 23 |
| Pumping station | 24 |
| Dispersion piping and manifolds | 25 |
| Control input devices | 28 |
| Start system to flush piping and manifolds | 29 |
| Flush dispersion piping and manifolds | 31 |
| Install atomizing nozzles | 31 |
| Test operation | 32 |

Table of contents

Operation

| | |
|--------------------------------------|----|
| Water quality | 33 |
| Atomizing nozzle operation | 35 |
| Using the touch-screen display | 36 |

Maintenance

| | |
|---|----|
| Pumping station: Reverse-osmosis water treatment components | 37 |
| Pumping station: High-pressure water pumping components | 38 |
| Water softener | 40 |
| Holding tank | 40 |
| High-pressure piping system | 41 |
| Nozzle maintenance | 41 |
| Troubleshooting guide | 42 |

| | |
|-----------------------|-------------------|
| Warranty | Back cover |
|-----------------------|-------------------|

System overview

Figure 6-1:
DRI-STEEM High-Pressure Atomizing System overview

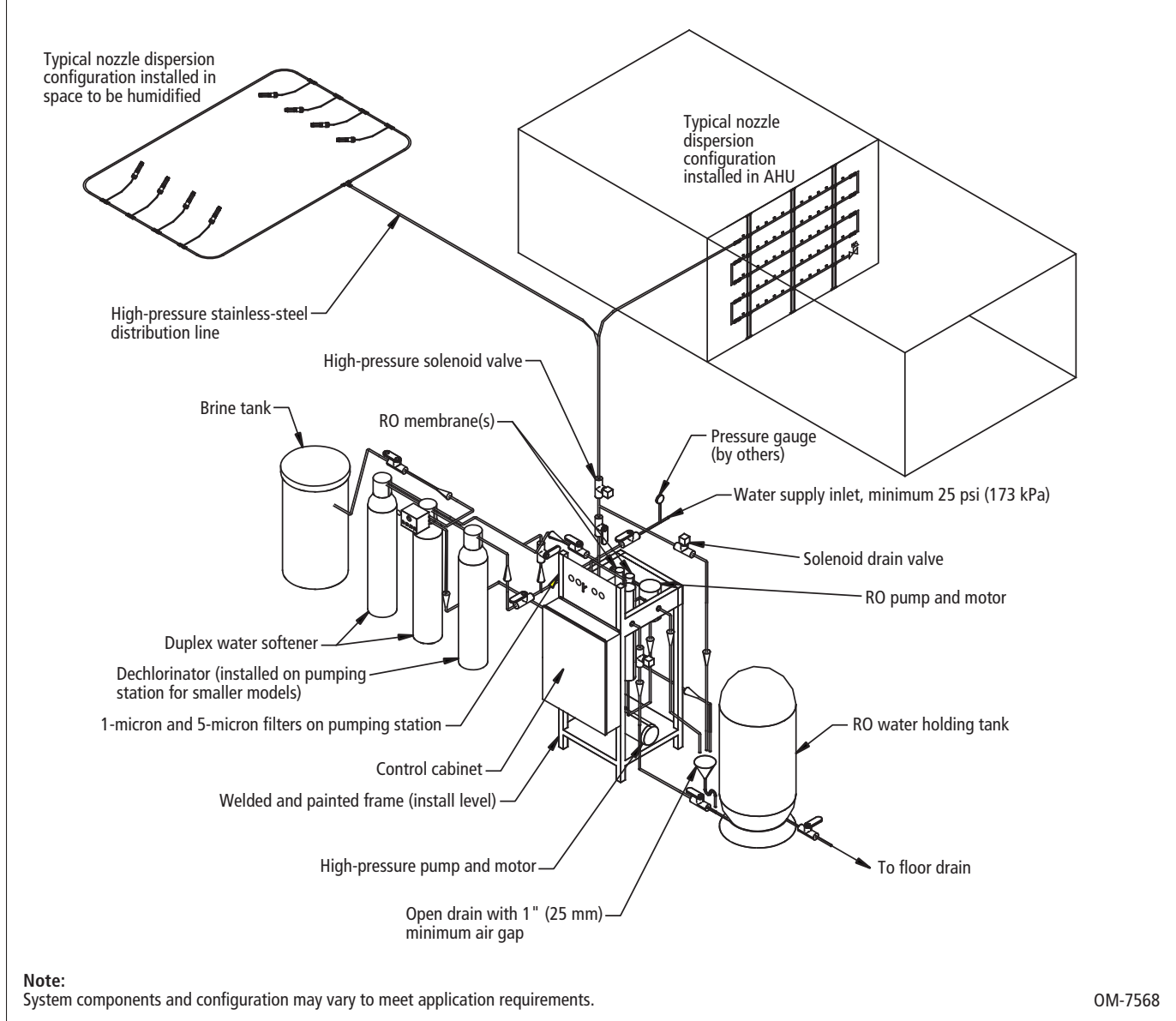

Note:
System components and configuration may vary to meet application requirements.

OM-7568

System dimensions

**Figure 7-1:
DRI-STEEM High-Pressure Atomizing System dimensions**

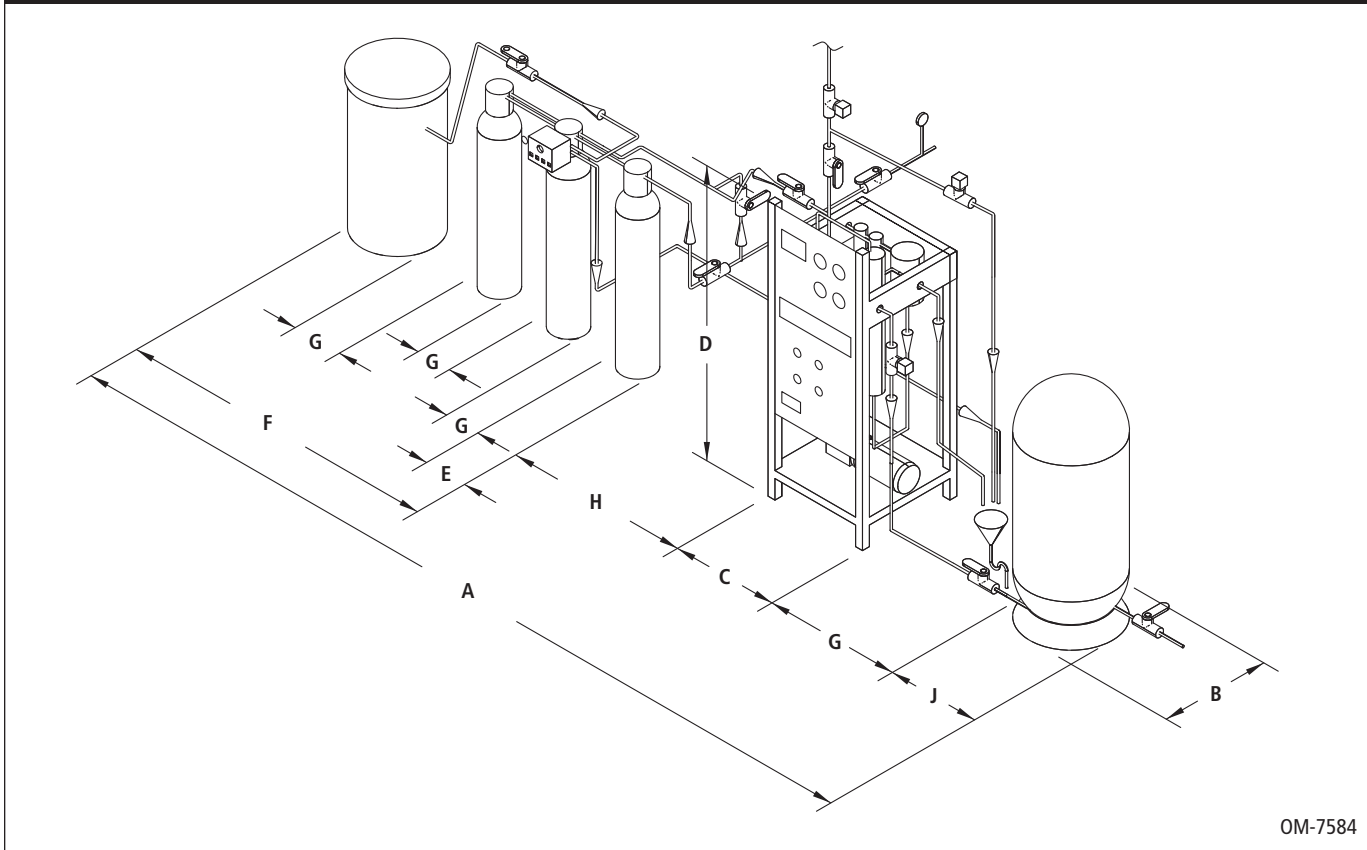

OM-7584

**Table 7-1:
DRI-STEEM High-Pressure Atomizing System dimensions**

| Model | Dimension | | | | | | | | | | | | | | | | | |
|-------|-----------|------|--------|------|--------|-----|--------|------|--------|-----|--------|------|--------|-----|--------|-----|--------|-----|
| | A* | | B | | C | | D | | E** | | F** | | G*** | | H | | J | |
| | inches | mm | inches | mm | inches | mm | inches | mm | inches | mm | inches | mm | inches | mm | inches | mm | inches | mm |
| 250 | 112 | 2845 | 24 | 610 | 24 | 610 | 56 | 1422 | 10 | 254 | 46 | 1168 | 4 | 102 | 10 | 254 | 24 | 610 |
| 500 | 112 | 2845 | 24 | 610 | 24 | 610 | 56 | 1422 | 10 | 254 | 46 | 1168 | 4 | 102 | 10 | 254 | 24 | 610 |
| 1000 | 116 | 2946 | 24 | 610 | 24 | 610 | 56 | 1422 | 12 | 305 | 50 | 1270 | 4 | 102 | 10 | 254 | 24 | 610 |
| 1500 | 116 | 2946 | 24 | 610 | 24 | 610 | 66 | 1676 | 12 | 305 | 50 | 1270 | 4 | 102 | 10 | 254 | 24 | 610 |
| 2000 | 120 | 3048 | 24 | 610 | 24 | 610 | 66 | 1676 | 16 | 406 | 54 | 1372 | 4 | 102 | 10 | 254 | 24 | 610 |
| 2500 | 128 | 3251 | 24 | 610 | 32 | 813 | 66 | 1676 | 16 | 406 | 54 | 1372 | 4 | 102 | 10 | 254 | 24 | 610 |
| 3750 | 128 | 3251 | 32 | 813 | 32 | 813 | 66 | 1676 | 16 | 406 | 54 | 1372 | 4 | 102 | 10 | 254 | 24 | 610 |
| 5000 | 120 | 3048 | 72 | 1829 | 24 | 610 | 60 | 1524 | 16 | 406 | 54 | 1372 | 4 | 102 | 10 | 254 | 24 | 610 |
| 6500 | 120 | 3048 | 72 | 1829 | 24 | 610 | 60 | 1524 | 16 | 406 | 54 | 1372 | 4 | 102 | 10 | 254 | 24 | 610 |
| 8500 | 120 | 3048 | 72 | 1829 | 24 | 610 | 60 | 1524 | 16 | 406 | 54 | 1372 | 4 | 102 | 10 | 254 | 24 | 610 |

Notes:

* Overall dimension depends on system configuration.

** Water treatment and tank dimensions depend on water quality and system size. Dimension may be smaller.

*** Recommended spacings. If access to all system components and replacement parts is adequate, these dimensions can be reduced.

Components overview

Components overview

Your system may include all or some of the following components.

- Water pretreatment components
 - Dechlorinator (floor mounted for Models 1500-8500 only)
 - Duplex water softener and brine tank
- Pumping station components
 - Dechlorinator (mounted within pumping station for Models 250-1000 only)
 - Reverse-osmosis water treatment components
 - High-pressure water pumping components
 - Gauges, valves
 - Control cabinet (can be remote-mounted)
- Purified water reserve tank
- Atomization piping, manifolds, nozzles, valves
- Mist eliminator
- Control transmitters and airflow switches

Specifications for components follow.

Components overview

Dechlorinator

The dechlorinator is mounted within the pumping station for Models 250-1000 and is floor-mounted for Models 1500-8500.

**Table 9-1:
Dechlorinator specifications**

| Model | Description | Dimensions (inches) | Connections |
|---------------|-------------------|---------------------|-------------|
| MEV10-AC-3000 | 1 ft ³ | 10" dia. x 65" | 1" NPT |
| MEV20-AC-3000 | 2 ft ³ | 12" dia. x 65" | 1" NPT |
| MEV30-AC-3000 | 3 ft ³ | 16" dia. x 65" | 1" NPT |
| MEV40-AC-3000 | 4 ft ³ | 16" dia. x 65" | 1.5" NPT |

Components overview

**Figure 10-1:
Duplex water softener and brine tank**



**Table 10-1:
Duplex softener specifications**

| Model | Description | Dimensions (inches) | | Weight (lbs) | | Connections |
|-----------|---|---------------------|--------|--------------|---------|--------------------|
| | | Diameter | Height | Net | Charged | |
| FHA 22F | 22,000 grains 0.66 ft ³ resin | 8 | 35 | 20 | 95 | ¾" dia. male NPT |
| FHA 30F | 30,000 grains 1 ft ³ resin | 10 | 44 | 35 | 145 | ¾" dia. male NPT |
| FHA 45F | 45,000 grains 1.5 ft ³ resin | 12 | 47 | 35 | 205 | ¾" dia. male NPT |
| FHA 90F | 90,000 grains 3 ft ³ resin | 14 | 65 | 50 | 380 | ¾" dia. male NPT |
| FHA 120DF | 120,000 grains 4 ft ³ resin | 14 | 65 | 65 | 650 | 1" dia. male NPT |
| TMI 150 | 150,000 grains 5 ft ³ resin | 21 | 54 | 100 | 700 | 1.5" dia. male NPT |

Notes:
 Maximum water pressure = 100 psi
 Operational power supply 120 Vac
 Dimensions listed are for each cylinder. Each model has two cylinders.

**Table 10-2:
Brine tank specifications**

| Connected to softener model | Dimensions (inches) | | Weight (lbs) | | Connections | Salt required (lbs) |
|---|---------------------|--------|--------------|-----------|-----------------------|---------------------|
| | Diameter | Height | Shipping | Operating | | |
| FHA-22F FHA-30F FHA-45F | 18 | 33 | 10 | 410 | ½" dia. male pushlock | 240 |
| FHA-90F TMI-(45 or 150) FHA-120DF | 18 | 40 | 15 | 415 | ½" dia. male pushlock | 320 |

Components overview

Pumping station

The pumping station arrives at the job site ready for single-point connection to power and water. Contained within the rugged, painted-steel frame are reverse-osmosis water treatment components, high-pressure water pumping components, a dechlorinating filter (floor mounted for capacities above 2 gpm), gauges, valves, and a control cabinet.

Figure 11-1:
Pumping station



Components overview

**Table 12-1:
Pumping station specifications**

| Model | 250 | 500 | 1000 | 1500 | 2000 | 2500 | 3500 | 5000 | 6500 | 8500 |
|--|---|---|---|---|--|----------------------------|----------------------------|----------------------------|----------------------------|----------------------------|
| System capacity (lbs/hr) | 250 | 500 | 1000 | 1500 | 2000 | 2500 | 3500 | 5000 | 6500 | 8500 |
| Max. system voltage/ phase, Amp draw | 220/1, 10.6 480/3, 2.8 600/3, 2.2 | 220/1, 16.6 480/3, 4.4 600/3, 3.6 | 220/1, 21.9 480/3, 5.8 600/3, 4.7 | 220/1, 30.6 480/3, 8.1 600/3, 6.6 | 480/3, 10.9 600/3, 8.9 | 480/3, 13.5 600/3, 11.0 | 480/3, 19.7 600/3, 16.0 | 480/3, 26.5 600/3, 21.5 | 480/3, 38.2 600/3, 31.1 | 480/3, 46.5 600/3, 37.8 |
| Pumping station dimensions inches (w x d x h) | 24 x 24 x 56 | 24 x 24 x 56 | 24 x 24 x 56 | 24 x 24 x 66 | 24 x 24 x 66 | 32 x 24 x 66 | 32 x 32 x 66 | 72 x 24 x 60 | 72 x 24 x 60 | 72 x 24 x 60 |
| Pumping station weight (lbs) | 350 | 450 | 500 | 650 | 750 | 800 | 1000 | 1200 | 1500 | 1800 |
| Supply water connection 25 psi min. (dia., inches) † | ¾ | ¾ | ¾ | 1 | 1 | 1 | 1 ½ | 1 ½ | 1 ½ | 2 |
| 5-micron RO prefilter inches (dia. x h) * | 2.5 x 20 | 2.5 x 20 | 2.5 x 20 | 4 x 20 | 4 x 20 | 4 x 20 | 4 x 20 | 4 x 20 | 4 x 20 | 4 x 20 |
| RO pump flow rate (gpd) * | 600 | 1500 | 3000 | 4500 | 6000 | 7500 | 10500 | 15000 | 20000 | 25000 |
| RO pump motor (hp) * | 0.5 | 1.5 | 1.5 | 3 | 3 | 5 | 7.5 | 10 | 15 | 20 |
| RO pump motor (rpm) * | 3600 | 3600 | 3600 | 3600 | 3600 | 3600 | 3600 | 3600 | 3600 | 3600 |
| RO membranes (number) * | 1 | 1 | 2 | 3 | 4 | 1 | 2 | 3 | 4 | 5 |
| RO membrane size inches (dia. x h) * | 4 x 20 | 4 x 40 | 4 x 40 | 4 x 40 | 4 x 40 | 8 x 40 | 8 x 40 | 8 x 40 | 8 x 40 | 8 x 40 |
| 1-micron high-pressure pump prefilter inches (dia. x h) ** | 2.5 x 10 | 2.5 x 10 | 2.5 x 20 | 4 x 20 | 4 x 20 | 4 x 20 | 4 x 20 | 4 x 20 | 4 x 20 | 4 x 20 |
| High-pressure water (post-RO) pump flow rate (gpm) ** | 0.5 | 1.0 | 2.0 | 3.0 | 4.0 | 5 | 7 | 10 | 13 | 17 |
| High-pressure water (post-RO) pump motor (hp) ** | 0.75 | 1.5 | 2 | 3 | 5 | 5 | 7.5 | 10 | 15 | 15 |
| High-pressure water (post-RO) pump motor (rpm) ** | 1800 | 1800 | 1800 | 1800 | 1800 | 1800 | 1800 | 1800 | 1800 | 1800 |
| * Reverse-osmosis water treatment components include: Multistage pump with all-stainless-steel body and wetted parts TEFC high-efficiency motor Start/stop stainless-steel pressure transmitter (30-50 psig) Water inlet low-pressure detection (3-10 psig) Water supply solenoid valve, 24 Vac, brass body RO pressure gauge, 0-400 psig, stainless steel, 2.5" dia., panel mounted Pure water tank pressure gauge, 0-100 psig, stainless steel, 2.5" dial, panel mounted Water inlet pressure gauge, 0-160 psig, stainless steel, 2.5" dia., panel mounted Pure-water tank pressure safety valve, 75 psig, tank mounted 5-micron RO prefilter with purge and cut-off valve Reject flow control pressure regulator, brass body Automatic membrane fast flush † 25 psi minimum water supply pressure required at inlet to pumping station | | | | | ** High-pressure water and pumping station components include: High-pressure, all-316-stainless-steel, quintuple-axial-piston pump, water cooled, water lubricated, maintenance free Direct-coupled pump motor, TEFC, heavy duty, high torque, 1800 rpm Pressure regulator with flow leak detection, stainless-steel wearing parts, calibrated between 500-1200 psig, front mounted Stainless-steel pressure gauge, 0-1500 psig, 2.5" dia., front mounted 1-micron high-pressure pump prefilter Thermal protection sensor, pump mounted Low-pressure switch, pump mounted Hydraulic vibration damper Leveling and anti-vibration legs Modular steel frame with epoxy-powder-coated finish RO water treatment components are integrated into pumping station framework | | | | | |

Components overview

Purified water reserve tank

The purified water reserve tank holds treated water in reserve to be available for high-pressure pumping when there is a call for humidity.

Figure 13-1:
Purified water reserve tank



| Table 13-1: Purified water reserve tank specifications | | | | | | |
|---|--|---------------------|--------|--------------|---------|-------------------------|
| Model | Description | Dimensions (inches) | | Weight (lbs) | | Connections |
| | | Diameter | Height | Net | Charged | |
| WM-12 | 40.3 gallon capacity 12 gallons of water | 16 | 57 | 35 | 135 | 1" dia. male NPT |
| WM-20WB | 60 gallon capacity 20 gallons of water | 24 | 41.25 | 61 | 221 | 1 1/4" dia. male NPT |
| WM-25WB | 86.7 gallon capacity 25 gallons of water | 24 | 55.25 | 84 | 284 | 1 1/4" male NPT |
| WM-35WB | 119.4 gallon capacity 35 gallons of water | 24 | 74.25 | 108 | 388 | 1 1/4" dia. male NPT |
| Notes: There is a possibility that the tank becomes much heavier if the air balloon is emptied. The weights and quantities of water in the storage tank are with an operating pressure of 30-50 psi. | | | | | | |

Components overview

Atomizing nozzles

Atomizing nozzles operate in ducts, air-handling units (AHUs), or in open spaces.

Figure 14-1:
Atomizing nozzle



Table 14-1:
Atomizing nozzle specifications

| Model | Description | Capacity (lbs/hr) | | | Connection |
|----------|--------------------------------------|-------------------|----------|----------|---------------------|
| | | 800 psi | 1000 psi | 1200 psi | |
| MHDAA-06 | Orifice dia. 0.006" O-ring yellow | 6 | 6.5 | 10 | 7/16" dia. male NPT |
| MHDAA-07 | Orifice dia. 0.008" O-ring red | 8.5 | 9 | 10.5 | 7/16" dia. male NPT |
| MHDAA-08 | Orifice dia. 0.012" O-ring black | 11.5 | 13 | 13.5 | 7/16" dia. male NPT |
| MHDAA-09 | Orifice dia. 0.020" O-ring green | 20.5 | 21.5 | 22.5 | 7/16" dia. male NPT |

Components overview

Mist eliminator

The mist eliminator, installed in the AHU downstream from the atomizing nozzles, removes unabsorbed water droplets from the air.

Control transmitters and switches

A system of temperature, humidity, and airflow transmitters/switches installed upstream and downstream from the atomizing nozzles and/or in humidified space(s) allow the system to quickly respond to humidification demand while avoiding over-saturation.

Components and tools needed

Components needed

Components supplied (system configuration may not include all components):

- Duplex water softener
- Brine tank
- Pumping station
- Dechlorinator (may be pump-station mounted)
- Stainless-steel tubing (1/2")
- Swagelok®-type unions
- 1/2" pipe supports/hangers
- Distribution manifold(s)
- Atomizing nozzles
- Flexible nozzle extenders (open space applications only)
- High-pressure shut-off valve(s) (1 per zone)
- Controls (transmitter(s), airflow switch)

Tools/supplies needed

- Stainless-steel tube bender (recommend Swagelok® Model MS-HTB-8 for 1/2" stainless-steel tubing)
- Thread sealant (recommend Loc-Tite® 545 or 565)
- Teflon-tape (recommend Oatey 31402)
- Pressure gauge (inlet water pressure)
- Three-wire shielded cable

Placing components

Clearances

Figure 17-1:
Minimum recommended clearances

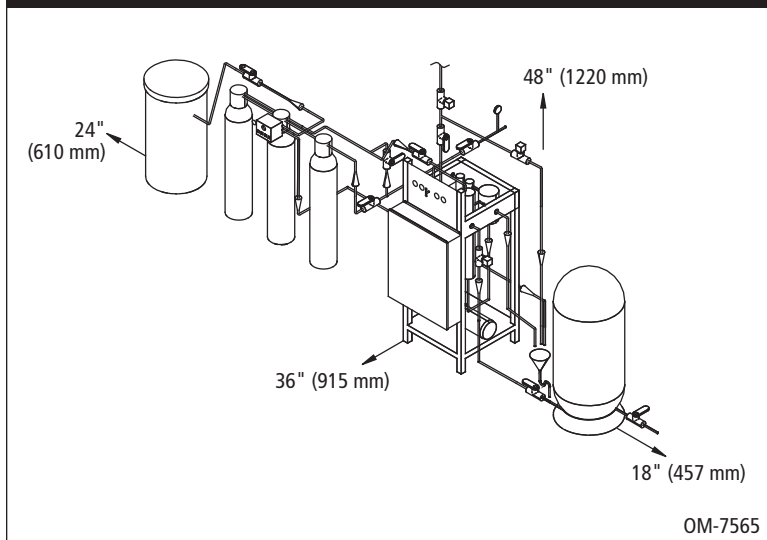

Placing dechlorinator, softener, and pumping station

- Select a location near a water supply, power supply, and drain.
- When possible, minimize distance between pumping station and dispersion assemblies.
- Note clearances shown in Figure 17-1

Placing components

Dechlorinator (floor mounted only)

- Never tilt dechlorinator tanks more than 30 degrees if it is filled with resin to avoid damaging internal components.
- Select a location with available top clearance of at least 48".
- Position the dechlorinator close to a surge-protected ground-fault (GFI) 120 Vac outlet so that water leakages cannot infiltrate the outlet.
- Position the dechlorinator within 15' of a drain.

Duplex water softener

- Never tilt softener tanks more than 30 degrees if they are filled with resin to avoid damaging internal components.
- Select a location with available top clearance of at least 48".
- Position the softener close to a surge-protected ground-fault (GFI) 120 Vac outlet so that water leakages cannot infiltrate the outlet.
- Position the softener within 15' of a drain.
- Install a water sampling port after the water softener and before the pumping station. This will be used for periodic water testing to ensure proper operation of the water treatment system.

Brine tank

- Select a location with at least 24" on one side the brine tank to allow the operator to replace the salt (up to 88 lbs [40 kg]). Allow a top clearance of at least 48".
- Select a location near the brine tank to store salt bags.
- Install the brine tank in a place that does not have a risk of freezing.
- Position the brine tank within 6' of the softener.
- Salt to be provided by the installer. Refer to Table 10-2 for quantities.

Important: Salt will have to be of water softener quality, free of mineral particles that do not dissolve.

Placing components

Pumping station

- Select a location with at least 18" clearance around the pumping station replaceable components to allow the operator to replace filters, oil (brass pump only), and for future maintenance.
- Select a location with available top clearance of at least 48" to allow inspection of the reverse osmosis membranes.
- Select a location with at least 36" in front of the unit to allow the operator to work with the display or for any maintenance in the control panel.
- Position the unit within 20' of an open drain.
- Select a location where electrical components will remain dry and the temperature remains above freezing.

Purified water reserve tank

- Select a location with at least 18" in front of the tank plumbing connection to allow the operator to drain the reserve.
- Select a location with available top clearance of at least 6" to allow the operator to check the air pressure in the storage tank.

Dispersion piping and manifolds

For area-type applications:

- Choose a location with at least a 12' ceiling height.
- Do not locate above a walkway.
- Do not locate over electrical equipment.
- Try to avoid obstructions such as piping and/or lighting, if possible.
- Consider any bends that might be required.
- A drain is required at the end of the distribution piping.

For AHU applications:

- Locate the dispersion manifold(s) in a section where there is at least 4' (1.2 m) of unobstructed space downstream and 1' (0.3 m) upstream.
- Ensure that the entire dispersion section of air handler is constructed of or lined with stainless steel to prevent corrosion. Pitch this dispersion section in the same direction as the airflow to a drain at or after the mist eliminators.
- Air velocities in the area should not exceed 1000 cfm (3.4 m³/h).
- Air temperatures should not be below 65 °F.
- Use the supplied rubber grommets around 1/2" stainless steel piping for all penetrations through the AHU/duct wall. Drill a 3/4" hole.

Placing components

Atomizing nozzles

For area-type applications:

- Select a location below the piping manifolds with accessibility for a lift truck or ladder to allow for replacement or cleaning of the nozzles.
- Allow at least 8' below the nozzles for obstacles.
- Support the dispersion piping every 5'.
- Select a location where electrical components will remain dry.
- Position the piping manifold with the threaded connections pointing up.
- Direct the nozzles so that they have at least 6" clearance above to prevent condensation on the ceiling.

For AHU applications:

- Select a location for the nozzles that allow space for an operator to check or replace them.
- Allow for a piping support every 5'.
- Select a location where electrical components will remain dry.
- Position the nozzles with the threaded connection against the airflow with a minimum angle of 30-45 degrees upwards or downwards, away from the nearest AHU surface.

Mist eliminators (AHU applications only):

- Locate as far as possible downstream of the dispersion manifolds.
- Cut the mounting rails to length, then affix to AHU/duct walls with the 3" tall rail on top and the 1" tall rail on the bottom.
- Slide the mist eliminator up into the 3" tall rail and allow to drop down into the 1" tall rail. Slide in other mist eliminators to cover entire cross section of the AHU/duct.

Important: Pitch the AHU/duct towards the mist eliminators and locate drain after the mist eliminators.

Placing components

Temperature/humidity and airflow sensors

- Allow at least 2' in front of the sensors to allow the operator to repair the equipment.
- Select locations where there is minimal mechanical or environmental risk of damage to the sensors.
- For AHU applications:
 - Position the control temperature and humidity sensor in the return air section where the air conditions are most similar to the space conditions being controlled.
 - Position the supply air temperature and humidity sensor at least 2' after the mist eliminator, where the conditions will be representative of the supply air. Ensure any obstacles, turns, or other components do not affect airflow near the sensor.
 - Position the air flow switch at least 5' upstream of the dispersion manifolds, in the same airstream.
- For area-type applications:
 - Position the sensor near where the conditions must be controlled.
 - Position the sensor away from where the humidification system is likely to influence them.
 - Position the sensor away from any other conflicting source of humidity or temperature.

Solenoid valves

- Allow at least 2' in front of the solenoid valves for access to the equipment.
- For area-type applications, install the solenoid valve near the pumping station.
- For AHU applications, install the solenoid valves close to the dispersion manifolds.
- Position the valves in places where they are sheltered from damage.

Connecting components

Water supply line pressure gauge

Install a pressure gauge in the supply water line to monitor incoming water pressure to the humidification system prior to the first component in the humidification/water treatment system.

Dechlorinator

For detailed instructions see the dechlorinator manual that shipped with your system.

Connecting components

Duplex water softener

For detailed instructions see the water softener manual that shipped with your system.

- Create two equal length pieces of 1" (DN25) copper tubing at least 6" (150 mm) long. These will be used to connect the two heads of the duplex water softener.
- Remove the brass connector on each head of the duplex water softener.
- Solder the copper tubing to the brass connections.
- Replace the soldered assembly and join the two water softener heads.
- Connect the water supply to the bypass assembly at the inlet to the duplex water softener.
- Connect the brine tank to the water softener control system using the plastic hose supplied.
- Add salt to the brine storage tank. **Note:** DRI-STEEM recommends using sea salt because it dissolves easily.
- Plumb drain outlet on the water softener (1/2" [DN15] hose) to nearby drain.
- Plug in the power cord to a receptacle.

Figure 23-1:
Copper tubing soldered to water softener head

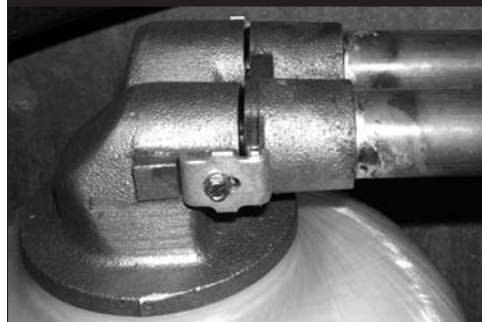

Figure 23-2:
Water softener bypass assembly

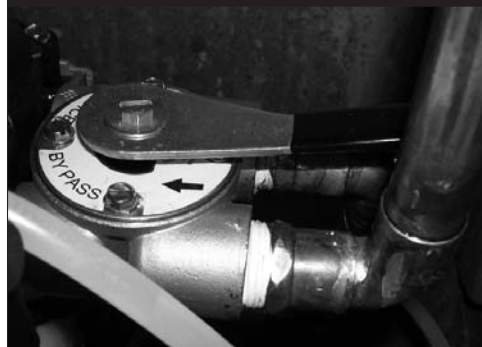

Figure 23-3:
Water softener and RO rejection water hoses connected to drain cup



Connecting components

**Figure 24-1:
Hose from RO water outlet connected
to reserve tank**



Pumping station

- Connect the outlet of the water softener to the pumping station inlet.
- Connect the RO water outlet on the pumping station to the purified water reserve tank.
- Plumb RO standard rejection drain connection (3/4" hose) to drain.
- Plumb RO fast flush drain connection (3/4" hose) to drain.
- Plumb RO water output to the storage tank.
- For Area-type application, plumb high-pressure solenoid drain relief to nearby drain.
- Using 1/2" stainless steel tubing, complete the connection between the pumping station and distribution manifold.
- Apply bends and pipe supports as required.
- Pipe supports to be a maximum of 8' apart.
- Tighten all unions.

Connecting components

Dispersion piping and manifolds

General instructions:

- Included in the dispersion installation kit are Swagelok® fittings. Use these fittings along with a Swagelok® tube bender (Model MS-HTB-8) to complete the dispersion and interconnecting piping installation.
- Best practice is to run the entire length of the interconnecting piping and dispersion manifolds first, and to then connect Swagelok® fittings hand-tight until the entire installation is completed.
- Do not bleed system by loosening fitting nut or fitting plug.
- Do not assemble or tighten fittings when system is pressurized.
- Make sure that the tubing rests firmly on the shoulder of tube fitting body before tightening the nut. See fitting installation instructions below.
- Always use proper thread sealants on tapered pipe threads.
- Never turn fitting body. Instead, hold fitting body and turn nut.
- Avoid unnecessary disassembly of unused fittings.

Initial installation instructions – Swagelok® fittings:

- Fully insert the tube into the fitting and against the shoulder, rotate the nut finger-tight.
- Mark the nut at the 6 o'clock position.
- While holding the fitting body steady, tighten the nut one and one-quarter turns to the 9 o'clock position.

Reassembly installation instructions – Swagelok® fittings:

- You may disassemble and reassemble Swagelok® tube fittings many times.
- Prior to disassembly, mark the tube at the back of the nut; mark a line along the nut and fitting body flats.
- Insert the tube with preswaged ferrules into the fitting until the front ferrule seats against the fitting body.
- While holding the fitting body steady, rotate the nut with a wrench to the previously pulled-up position, as indicated by the marks on the tube and flats. At this point, you will feel a significant increase in resistance. Tighten the nut slightly.

Figure 25-1:
Drain at end of distribution piping (for connection to a hose)



Connecting components

For area-type applications:

- Place pipe supports and/or hangers where the distribution manifold will be placed. Place pipe supports no more than 8' (2.4 m) apart.
- Place the first section of distribution manifold into place using the pipe supports. **Note:** Keep plugs in the manifold until the system has been flushed.
- Measure and make any bends that are required to avoid obstructions.
- Place a Swagelok®-type union on each side of distribution piping.
- Place the next section of distribution manifold.
- Connect the two sections using the union. **Note:** Make union connections hand-tight only until the distribution system is fully assembled.
- Continue until the entire zone manifold is in place.
- Install a ball valve for manual drainage of the distribution piping at the end.
- Tighten all unions.

Connecting components

Install dispersion piping and manifolds (cont.)

For AHU applications

- For multiple dispersion assemblies refer to manifold drawings supplied with the humidifier.
- Install a support system for each manifold.
- Mount each of the manifolds into place while maintaining the spacing via the end connects.

Note: Keep nozzle-location plugs in the manifold until the system is flushed.

- Place Swagelok®-type union on each side of the distribution piping.

Note: Make union connections hand-tight only until the distribution system is fully assembled.

- Connect the ends of the manifolds using the end connectors.
- Connect the high-pressure solenoid valve on the supply side of the manifold.
- Connect the drain valve to the end of the manifold section.
- Adjust any manifolds within 1' of the ceiling so that they are pointing downwards at a maximum of 45 degrees from horizontal.
- Adjust remaining rows of the manifold to point upwards at a maximum of 45 degrees from horizontal.
- Tighten all unions.

Important: Leave the brass plugs that ship in the dispersion manifolds in place until after system leakage test (Page 31). Ensure all plugs are tight before test.

Figure 27-1:
Drain valve and drain piping at end of manifold section

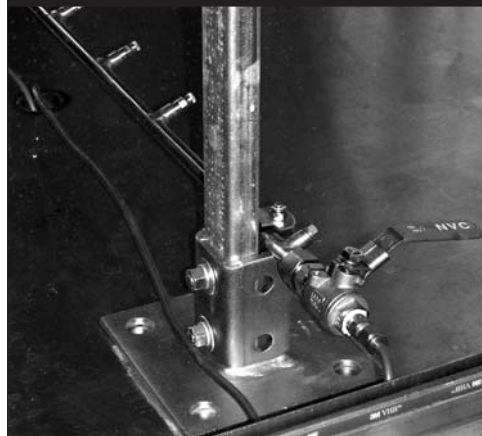

Figure 27-2:
Top row points downwards, other rows point upwards



Connecting components

Control input devices

Area-type applications:

- Install a room RH transmitter mounted to a standard 4" × 4" electrical junction box.
- Wire the transmitter to the pumping station control cabinet.

AHU applications:

- Install the airflow-proving switch at least 5' upstream of the dispersion manifolds.
- Install the temperature/humidity sensor upstream of the dispersion manifolds. Connect wiring per instructions packaged with sensor.
- Install the temperature/humidity sensor at least 2' downstream of the mist eliminators.
- Wire control devices to the pumping station control cabinet.
- Connect high-pressure solenoid valves to the control cabinet.
- Connect line power to the control cabinet.

Connecting components

Start system to flush piping and manifolds

1. Open water supply valve to the dechlorinator or water softener.
2. Verify no leaks exist.
3. Close the bypass valve at the water softener a little at a time to slowly fill and avoid getting resin in the head.
4. Verify no leaks exist at the water softener and in the piping to the pumping station.
5. Ensure that the water softener beds fill. A shadow will be noticeable through the container.
6. Manually adjust the controller to flush one of the beds.
7. When the first bed has finished the flush, manually adjust the controller to flush the other bed. This step can be accomplished anytime prior to step 33.
8. Open the main inlet water valve at the pumping station.
9. Dechlorinator and/or 5-micron filter will fill with water.
10. Press the button on top to relieve some pressure and ensure all air trapped in the system is removed.
11. Remove the bracket holding the stainless steel RO cap.
12. Remove the RO membrane chamber cap.
13. Locate the RO membrane and open the package.
14. Check to make sure the membrane is still moist.
15. Locate the O-ring and position so that the flared end is pointing toward the center of the membrane to avoid damaging the membrane.
16. Install the membrane into the chamber with the O-ring on the top.
17. Replace the cap.
18. Replace the bracket.
19. Open the osmosis regulator fully to bleed air out.

Connecting components

20. Verify the System Water Supply pressure gauge displays above 5 psi.
21. Open the valve to the storage tank.
22. Verify that the High-Pressure Pump switch is Off.
23. Start the RO pump using the switch on the front of the control cabinet.
24. Slowly adjust the RO Pump Pressure Regulator until the pressure reads around 200 psi.
25. Bleed air from the 1-micron filter using the red button on top.
26. Let the system continue to operate and pressurize the storage tank to a nominal 50 psi.
27. RO system pump should automatically turn off after the nominal 50 psi is developed at the storage tank.
28. Connect a hose to the storage tank drain valve to nearby drain.
29. Switch off the RO pump.
30. Open the storage tank drain valve to flush the RO storage tank and interconnecting piping.
31. Drain the storage tank entirely.
32. Close the storage tank drain valve.
33. Check to see that both water-softening beds have been flushed. See step 7.
34. Switch the RO pump to operate and pressurize the storage tank again.

Connecting components

Flush dispersion piping and manifolds

1. Verify that the storage tank is full and at a nominal 50 psi.
2. Open the drain valve(s) at the end of the distribution piping.
3. Connect a hose to the manifold drain to nearby drain.
4. Turn on the high pressure pump.
5. Verify that water is discharged through the hose.
6. Operate the system for a few minutes to flush the distribution system.
7. Switch the high pressure pump off.
8. Close the drain valve at the end of the distribution manifold.

Install atomizing nozzles

Area-Type applications:

- Connect the nozzle to the flexible tubing.
 - Be careful handling the nozzle as impacts may affect performance.
 - Do not over-tighten (hand-tight to the adapter is sufficient).
- Remove the plug at the saddle outlet.
- Install the nozzle.
 - Do not over-tighten (hand-tight to the adapter is sufficient).
- Adjust the nozzle orientation using the flexible connector to avoid obstacles.
 - Hold the flexible tubing at the manifold end to avoid overstressing the welded connection.
- Repeat until all plugs have been replaced with nozzle assemblies.

AHU applications:

- Remove the plug at the saddle outlet.
- Install the nozzle.
 - Do not over-tighten (hand tight to the adapter is sufficient)-
- Repeat until all plugs have been replaced with nozzle assemblies.

Test operation

Test operation

1. Switch the high pressure pump to On.
2. Adjust the set-point to cause the distribution system to operate.
3. Monitor the nozzle performance and watch for leaks.
4. If a leak is found:
 - Turn the high pressure pump Off.
 - Tighten the loose connection.
 - Restart the high pressure pump.
 - If leak persists, replace the nozzle and/or nozzle assembly.
5. Adjust the set-point to desired.
6. Unit should operate automatically.

Water quality

Water quality

Supply water must be softened and dechlorinated before being pumped through the reverse-osmosis water treatment and high-pressure water pumping components. If you are not installing DRI-STEEM water pretreatment components, verify that your water is at least of reverse-osmosis quality.

Dechlorinator removes chlorine

The dechlorinator removes chlorine from supply water before it enters the reverse osmosis membranes.

Supply water enters the dechlorinator and passes through a charcoal sieve, which neutralizes chlorine before entering the water softener. The dechlorinator is automatically backflushed whenever a programmed calendar date or water meter usage is met. During automatic backflushing, clean water flows through the dechlorinator to rinse the charcoal, and then flows to drain.

Water softener removes calcium, magnesium, iron, and organics

The water softener removes dissolved minerals and organic matter from supply water before it enters the reverse osmosis membranes. Water not properly dechlorinated or softened damages reverse osmosis membranes and also causes atomizing nozzles to clog.

Water passes from the dechlorinator into the softener where dissolved minerals are removed by an ion-exchange process. Softened water exits through a water meter to enter the reverse osmosis membranes. When the water meter is satisfied, the softener will trap brine from the brine tank to flow the opposite way through the softener in order to regenerate the resin. Water will be rejected to drain during this period of rinsing.

Water quality



CAUTION

Water supplied to the reverse-osmosis and high-pressure water components that do not meet the required water quality standards will cause premature component failure and void the DRI-STEEM warranty.

Reverse osmosis membranes eliminate remaining minerals

Dissolved minerals must be eliminated from the water in order to keep system components operating properly. First, potable water passes through a dechlorinator and duplex water softener to take out chlorine and hard water deposits. The softened water enters the DRI-STEEM pumping station, then flows through a 5 micron filter cartridge. Thereafter, a multi-stage pump pressurizes the water to approximately 225 psig, depending on the quality of water and the desired flow. Then, water is forced to cross a reverse-osmosis membrane, which removes most dissolved minerals. The water is now purified and contains very few minerals (less than 10 ppm) and is then stored in the pressurized storage tank. The rejection water, which is saturated with minerals, is sent to drain.

Atomizing nozzle operation

Atomizing nozzle operation

- First, reverse-osmosis water stored in the pressurized storage tank is pumped by the high-pressure pump which increases the water pressure in the high-pressure atomizing network to approximately 1000 psig.
- On a demand from the control system a solenoid valve opens and lets water flow to the atomizing nozzles.
- Next, pressurized water arrives at the atomizing nozzles. Inside each nozzle is a mini-turbine that fragments water before it is forced through the nozzle orifice.
- These very fine fragmented droplets quickly evaporate and are absorbed into the air, increasing the relative humidity.

Using the touch-screen display

**Table 36-1:
Touch-screen controller menu structure**

| Screen | Menu item | Description |
|-----------------|---------------------------------------|---|
| Main screen | Humidification zone | Displays all zones controlled by this pumping station |
| | System status | Displays status of: <ul style="list-style-type: none"> • High-pressure pump (as well as which pump is operational in a redundant-pump setup) • RO pump (if included) • Main system valve • RO holding tank pressure (if included) • Time Until Service timer (reset button is on this screen) |
| | System settings | Displays: <ul style="list-style-type: none"> • High-pressure pump set point • Each zone's high-limit set point • High-pressure pump selection button (for systems with a redundant high-pressure pump only) • Technical Settings button • Manual Purge button |
| | Alarm history | Displays the date and description of alarms. <ul style="list-style-type: none"> • Note: Use the High-Pressure Pump or RO Pump toggle switch on the front of the control cabinet to cycle power as necessary to clear the alarm and retry. Use the troubleshooting section of this manual for detailed troubleshooting. • Press the Reset Buzzer button to top the audible alarm. |
| Zone # | Selection button for each system zone | Displays: <ul style="list-style-type: none"> • Zone number • Sensor readings for the selected zone • Selection button to input RH set point (demand by DRI-STEEM) • System demand % (demand by others) • Status of each stage in the selected zone • Toggle button for controlling the selected zone: <ul style="list-style-type: none"> – Auto: System is operated at the system demand – Off: System is in standby mode and will not operate – Manual: System is demanded on at 100% until turned off. System will automatically shut off after a certain period of time. |
| System settings | High-pressure pump | For systems with redundant high-pressure pump only. Displays: <ul style="list-style-type: none"> • Toggle button to enable or disable each high-pressure pump • Pump selection button to toggle between high-pressure pumps |
| | Technical settings | Displays: <ul style="list-style-type: none"> • RO membrane flush frequency (RO water option only) • High-pressure alarm delay time • VFD response time • Supply water alarm delay time • Maintenance timer set point • AHU sensor sampling rate |
| | Manual purge | Displays: <ul style="list-style-type: none"> • Table correlating the zone number to the purge zone number (if different from the zone number) • Identity of zone being purged (if any) • Selection to start purging the selected zone. <p>Important: After purging the zone, enter 0 in this button to shut off the purging process.</p> |

Maintenance

Pumping station: Reverse-osmosis water treatment components

5-micron prefilter cartridge

A dirty filter cartridge can restrict water flow to the RO pump, causing irreparable pump damage. Restricted water flow to the high-pressure pump can also cause abnormal noise and vibration.

Check the condition of your filter cartridge regularly and replace when dirty. Filter cartridges are available from your DRI-STEEM representative. Replacement frequency varies depending on the quality of water delivered to the filter cartridge. If the filter cartridge has to be replaced frequently, more than twice a year, verify all water pretreatment components are operating correctly.

To replace the RO pump prefilter cartridge:

1. Remove power to the pumping station.
2. Close the water supply valve located before the filter cartridge.
3. Drain the filter cartridge by pressing the button on the filter unit.
4. With two hands, hold the cartridge container firmly and remove by turning in a clockwise direction.
5. Before installing a new filter cartridge, make sure the o-ring is present. Coat the surface of the o-ring with petroleum jelly before closing the filter cartridge. Turn the filter cartridge until tight.
6. Open the water supply valve, located before the filter cartridge.
7. Remove air from the filter cartridge by pressing the button on the filter unit.
8. Turn on power to the pumping station.

Membrane filters

- Ensure outlet pressure is above 5 psi.
- Ensure that water is flowing from both the pure water outlet and the rejection water outlet.

Maintenance

Pumping station: High-pressure water pumping components

1-micron high-pressure pump prefilter cartridge

A dirty filter cartridge can restrict water flow to the high-pressure pump, causing irreparable pump damage. Restricted water flow to the high-pressure pump can also cause abnormal noise and vibration.

Check the condition of your filter cartridge regularly and replace when dirty. Filter cartridges are available from your DRI-STEEM representative. Replacement frequency varies depending on the quality of water delivered to the filter cartridge. If the filter cartridge has to be replaced frequently, more than twice a year, verify all water pretreatment components are operating correctly.

To replace the high-pressure pump prefilter cartridge:

1. Remove power to the pumping station.
2. Close the water supply valve located before the filter cartridge.
3. Drain the filter cartridge by pressing the button on the filter unit.
4. With two hands, hold the cartridge container firmly and remove by turning in a clockwise direction.
5. Before installing a new filter cartridge, make sure the o-ring is present. Coat the surface of the o-ring with petroleum jelly before closing the filter cartridge. Turn the filter cartridge until tight.
6. Open the water supply valve, located before the filter cartridge.
7. Remove air from the filter cartridge by pressing the button on the filter unit.
8. Turn on power to the pumping station.

Maintenance

High-pressure pumps

- Simulate stopping the low-pressure switch by closing the RO supply valve. The unit should shut down on a low pressure alarm. Check annually.
- Check strap tightness by pulling on the straps that hold the pump to the frame. Tighten if necessary.
- There are two types of pumps: stainless steel and brass. The stainless steel high-pressure pump requires no maintenance throughout its service life.
- Brass high-pressure pump maintenance (optionally available on single zone area-type applications only):
 - The brass high-pressure pump unit is prefilled with oil especially made for your pump. The brass pump oil is SAE 30 hydraulic-grade containing anti-foam and other additives and is available from your DRI-STEEM representative.
 - Check pump oil level every week by visual inspection of the oil reservoir.
 - Change the pump oil after the first 50 hours of operation and then after every 400 hours or four months of operation thereafter.
 - If the pump has not been in operation for more than a year, drain and replace the oil before restarting.
 - To drain and replace oil in the brass high-pressure pump:
 1. Turn off the high-pressure pump unit.
 2. Place a container under the pump's oil pan.
 3. Remove the nut located at the bottom of the oil pan. (Removal of the oil fill cap will allow faster draining.) Allow oil to drain completely.
 4. Replace the drain nut and tighten.
 5. Add new oil through the fill cap to the fill line. Use only DRI-STEEM pump oil.
 6. Check oil level with dipstick on the oil cap. Add oil until you reach the recommended level.
 7. Confirm oil level by viewing the oil pan site glass. The oil level should be at the central point. **DO NOT OVERFILL.**

Maintenance

Control system

Verify proper operation by visual inspection during normal operation.

Gauges and valves

Verify proper operation by visual inspection during normal operation.

Water softener

1. Visually inspect components for leaks or breakage.
2. Inspect Venturi and hopper for blockage.
3. Lubricate the controller on top of the unit. Remove the cover and lubricate the gears with an industrial lubricant.

Holding tank

1. Calibrate tank pressure to between 30 and 50 psi using an air pressure gauge at the plug on top of the tank.
2. Check the stop-and-go pressostat:
 - Drain tank until RO generation cycle begins. Verify starting and stopping pressures are approximately 30 psi and 50 psi respectively.
3. Check the low-pressure pressostat
 - Drain tank and verify RO generation begins at approximately 30 psi.

Maintenance

High-pressure piping system

Every three months, verify that all joints are watertight.

Nozzle maintenance

Nozzles are virtually maintenance-free when used with properly treated water.

Inspect every month to ensure proper operation:

1. **O-rings.** Nozzles are watertight because of o-rings located between the nozzle and the adapter. Inspect to ensure water tightness. When replacing, hand-tighten until the nozzle seats on the adapter. Never use tools to tighten nozzles, if the o-ring is over-compressed it can crack or bend, causing leakage. Make sure all components are free of any dust, oil or grease when you install them. Flush and drain high-pressure lines after replacing parts.
2. **Filters.** If nozzles are not dispersing water, the nozzle filter could be clogged. Remove nozzle filter and replace the filter. Make sure the replacement parts are free of any dust, oil or grease when you install them. Flush and drain high-pressure lines after replacing parts.

Troubleshooting guide

**Table 42-1:
Troubleshooting guide**

| Issue | Action |
|--|--|
| The system does not start manually or automatically. | Check supply voltage. Check circuit breakers. |
| | Verify low-pressure manual water supply valve is in the Open position. Verify water pressure is at least 25 psi. Verify cartridge filter is clean. Verify the low-pressure water supply solenoid electrical valve opens when the pump is operating. |
| | Check for alarms. |
| | Check the control and power fuses located inside the control and power panel. Check the 120V/24V transformer. |
| | Verify that actual relative humidity is lower than desired relative humidity. Verify that the device sending the humidity demand signal is operating. Verify that the humidity detection instrument is calibrated correctly. |
| | Verify main switch at the control and power panel is in the On position. |
| The system is operating but provides only low pressure or no pressure. | The pressure gauge located on the pump should indicate approximately 1000 psi. If needed, adjust the operating pressure with the pressure regulator. |
| | Check if there are any leaks in the high-pressure lines. Repair if needed. |
| | Verify the zone drain actuator is not blocked and is turned off. |
| | Verify the low-pressure water supply is in the On position. Verify the low-pressure water supply is at least 25 psi. Verify the filter cartridge is clean. Verify the low-pressure water supply solenoid electrical valve opens when the pump is operating. |
| | Verify the thermal safety valve is operating correctly. |
| | Verify the high-pressure lines are adequately drained with no air in the lines. |
| The thermal protection is tripped. | Make sure that there is adequate ventilation around the motor to keep it from overheating. Verify the motor fan is operating and unobstructed. |
| | Verify that the voltage and amperage of the motor electrical supply is adequate and follows the specifications written on the motor. Make sure the thermal protection of the motor is calibrated. If you need help, please ask an electrician. |
| | Verify the pressure manometer located on the pump indicates approximately 1000 psi. If needed, adjust the operating pressure with the pressure regulator. |
| | Verify the oil level of the oil pan (sump) is correct and that the oil is clean (brass high-pressure pump only). |
| | Verify the humidifying nozzles or line filters are not sealed off. |
| | Verify the high-pressure zone actuators are not blocked and are in the On position. |
| Verify the high-pressure zone manual valve is in the On position. | |

Troubleshooting guide

**Table 43-1:
Troubleshooting guide**

| Issue | Action |
|---|--|
| The unit turns on but it turns off after a certain period of time; the warning light is on. | Verify low-pressure manual water supply valve is in the Open position. Verify water pressure is at least 25 psi. Verify cartridge filter is clean. Verify the low-pressure water supply solenoid electrical valve opens when the pump is operating. |
| | Verify there are no leaks in the high-pressure network. Repair if needed. |
| | Verify the drain zone actuator is not blocked and is in the Off position. |
| | Verify the high-pressure zone manual valve is in the On position. |
| | Verify the high-pressure zone actuator is not blocked and is on the On position. |
| | Verify the pressure manometer located on the pump indicates approximately 1000 psi. If needed, adjust the operating pressure with the pressure regulator. |
| | Verify the humidifying nozzles and the filter are not clogged. |
| | Verify the oil level of the oil pan (sump) is correct and that the oil is clean. |
| | Make sure that 20% of the pump flow capacity (gpm) is used. |
| | Verify the thermal safety valve is not tripped. |
| | In order to make the pump unit operate again, push the main switch on the power and control panel. |
| The thermal safety valve is often in the On position. | Verify the high-pressure zone actuator is not blocked and is in the On position. |
| | Verify the high-pressure zone manual valve is in the On position. |
| | Verify the humidifying nozzles or line filter are not sealed off. |
| Some humidifying nozzles do not humidify enough or do not humidify at all. | Make sure the humidifying nozzles or filters are not clogged. Replace if needed. |
| | Verify low-pressure manual water supply valve is in the Open position. Verify water pressure is at least 25 psi. Verify cartridge filter is clean. Verify the low-pressure water supply solenoid electrical valve opens when the pump is operating. |
| | Verify the high-pressure pump gauge indicates approximately 1000 psi. If needed, adjust the operating pressure with the pressure regulator. |
| | Verify the high-pressure zone actuator is not blocked and is in the On position. |
| | Verify the high-pressure zone manual valve is in the On position. |
| | Verify the drain zone actuator is not blocked and is in the Off position. |
| | Verify the thermal safety valve is not in the On position. |
| High-pressure pump emits abnormal noises and excessive vibrations (cavitation) | Verify low-pressure manual water supply valve is in the Open position. Verify water pressure is at least 25 psi. Verify cartridge filter is clean. Verify the low-pressure water supply solenoid electrical valve opens when the pump is operating. |
| | Verify the low-pressure water supply passage is not blocked. |
| | Verify the water supply flow of the pump is adequate. |
| | Verify the pump and motor are not exceeding recommended revolutions per minute (rpm). |
| | Verify ball valves are in the On position. |
| | |

Expect quality from the industry leader

For more than 45 years, DRI-STEEM has been leading the industry with creative and reliable humidification solutions. Our focus on quality is evident in the construction of the High-Pressure Atomizing System, which features cleanable, stainless steel construction. DRI-STEEM also leads the industry with a Two-year Limited Warranty and optional extended warranty.

For more information

www.dristeem.com
sales@dristeem.com

For the most recent production information visit our web site:

www.dristeem.com

DRI-STEEM Corporation

An ISO 9001:2000 certified company

U.S. Headquarters:

14949 Technology Drive
Eden Prairie, MN 55344
800-328-4447 or 952-949-2415
952-229-3200 (fax)

European office:

Marc Briers
Grote Hellekensstraat 54 b
B-3520 Zonhoven
Belgium
+3211823595 (voice)
+3211817948 (fax)
E-mail: marc.briers@dristeem.com

Continuous product improvement is a policy of DRI-STEEM Corporation; therefore, product features and specifications are subject to change without notice.

DRI-STEEM is a registered trademarks of DRI-STEEM Corporation and is filed for trademark registration in Canada and the European community.

Product and corporate names used in this document may be trademarks or registered trademarks. They are used for explanation only without intent to infringe.

© 2010 DRI-STEEM Corporation

Form No. HPAS-IOM-0510
Part No. 890000-850

Two-year Limited Warranty

DRI-STEEM Corporation ("DRI-STEEM") warrants to the original user that its products will be free from defects in materials and workmanship for a period of two (2) years after installation or twenty-seven (27) months from the date DRI-STEEM ships such product, whichever date is the earlier.

If any DRI-STEEM product is found to be defective in material or workmanship during the applicable warranty period, DRI-STEEM's entire liability, and the purchaser's sole and exclusive remedy, shall be the repair or replacement of the defective product, or the refund of the purchase price, at DRI-STEEM's election. DRI-STEEM shall not be liable for any costs or expenses, whether direct or indirect, associated with the installation, removal or reinstallation of any defective product. The Limited Warranty does not include cylinder replacement for electrode steam humidifiers.

DRI-STEEM's Limited Warranty shall not be effective or actionable unless there is compliance with all installation and operating instructions furnished by DRI-STEEM, or if the products have been modified or altered without the written consent of DRI-STEEM, or if such products have been subject to accident, misuse, mishandling, tampering, negligence or improper maintenance. Any warranty claim must be submitted to DRI-STEEM in writing within the stated warranty period. Defective parts may be required to be returned to DRI-STEEM.

DRI-STEEM's Limited Warranty is made in lieu of, and DRI-STEEM disclaims all other warranties, whether express or implied, including but not limited to any IMPLIED WARRANTY OF MERCHANTABILITY, ANY IMPLIED WARRANTY OF FITNESS FOR A PARTICULAR PURPOSE, any implied warranty arising out of a course of dealing or of performance, custom or usage of trade.

DRI-STEEM SHALL NOT, UNDER ANY CIRCUMSTANCES BE LIABLE FOR ANY DIRECT, INDIRECT, INCIDENTAL, SPECIAL OR CONSEQUENTIAL DAMAGES (INCLUDING, BUT NOT LIMITED TO, LOSS OF PROFITS, REVENUE OR BUSINESS) OR DAMAGE OR INJURY TO PERSONS OR PROPERTY IN ANY WAY RELATED TO THE MANUFACTURE OR THE USE OF ITS PRODUCTS. The exclusion applies regardless of whether such damages are sought based on breach of warranty, breach of contract, negligence, strict liability in tort, or any other legal theory, even if DRI-STEEM has notice of the possibility of such damages.

By purchasing DRI-STEEM's products, the purchaser agrees to the terms and conditions of this Limited Warranty.

Extended warranty

The original user may extend the term of the DRI-STEEM Limited Warranty for a limited number of months past the initial applicable warranty period and term provided in the first paragraph of this Limited Warranty. All the terms and conditions of the Limited Warranty during the initial applicable warranty period and term shall apply during any extended term. An extended warranty term of an additional twelve (12) months or twenty four (24) months of coverage may be purchased. The extended warranty term may be purchased until eighteen (18) months after the product is shipped, after which time no extended warranties are available.

Any extension of the Limited Warranty under this program must be in writing, signed by DRI-STEEM, and paid for in full by the purchaser.

mc_051308_0630

