

DRISTEEM[®]
The humidification experts



Vapor-logic[®]4 controller with:

- Web-enabled remote access
- Modbus[®], BACnet[®], and LonTalk[®] interoperability

GTS[®]
Gas-to-Steam
Humidification System
PRODUCT CATALOG



Save with gas humidification

Gas has lowest energy operating costs

The industry's first and best-selling gas-to-steam (GTS®) humidifier continues to be your best choice for reducing energy costs — both consumption and demand charges.

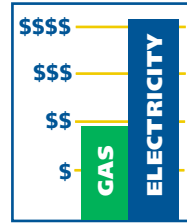

To calculate how much you can save by switching from an electric humidifier to a gas humidifier, use our Energy Savings Calculator at www.dristeem.com/energycalc.jsp

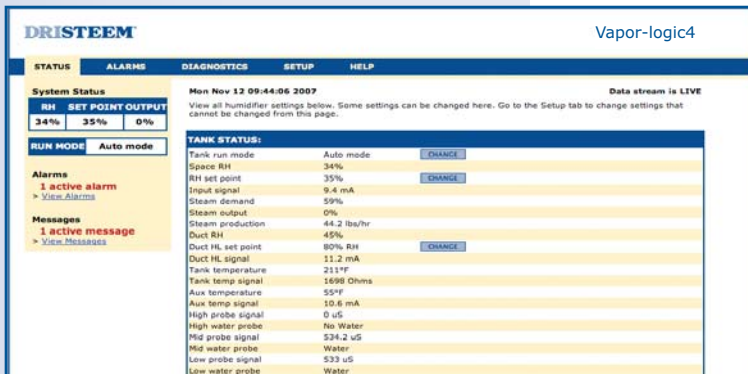

Convenient Web-enabled remote access with Vapor-logic4

DRI-STEEM's fourth-generation controller Vapor-logic⁴ allows, as standard, humidifier control from a keypad or from a Web interface. This provides the capability to securely set up, view, or adjust humidifier system functions from virtually anywhere — and at any time.

Connect with Modbus®, BACnet®, or LonTalk®

GTS humidifiers with Vapor-logic4 are fully interoperable with Modbus, BACnet, and LonTalk systems. Vapor-logic4 can communicate with building automation systems using Modbus, its native language, or by using optional BACnet or LonTalk.



More benefits of the best-selling gas-to-steam humidifier . . .

- **8 unit capacities from 75–600 lbs/hr**, including new GTS-500 and GTS-700 models
- **Easy software updates** through the USB port on the Vapor-logic4 board
- **View operational data** from the keypad or from the Web interface
- **Accurate, responsive, adjustable RH control** due to full burner modulation and PID control
- **Capacity range up to 9,600 lbs/hr** (4,352 kg/h) (16 units under one controller)
- **Automatically cools discharged hot water** to 140 °F (60 °C) to meet governing code safety requirements
- **Enclosures for virtually any environment.** Indoor and outdoor; factory-installed
- **Space conscious and streamlined.** All humidifier components are contained within enclosures — no separate control cabinets or wiring subpanels
- **Full service access.** Lift-off panels remove for easy access to all connection points

More GTS features and benefits

Proven performance

- Control to $\pm 3\%$ RH
- Steam output rangeability up to 40:1
- Low nitrogen oxide (NO_x) emissions of less than 20 ppm
- On-board diagnostics verify system operation
- Up to 84% burner efficiency rating
- Variable speed blowers and modulating gas valves provide consistent humidity output
- Designed and tested to meet ARI-640 humidification standard

Application flexibility

- Capacity range to 600 lbs/hr (272 kg/h) for each unit; link up to 16 units for capacity to 9,600 lbs/hr (4,352 kg/h)
- Supports all water types: tap, softened, reverse osmosis, or deionized; easy to field convert if water type changes
- Supports natural and LP gas
- Outdoor enclosure available for outdoor operation in any climate
- CSA/AGA/CGA approved for sealed combustion
- Requires only two-sided access, allowing installation in tight spaces
- Horizontal or vertical venting
- Uses affordable Category 1 venting materials for all options, including sealed combustion

Minimal maintenance

- Cleanout plate and removable panels provide easy access for inspection and servicing
- Use of softened water significantly reduces maintenance requirements
- End-of-season autodrain minimizes microbial growth
- Controller-operated drain and flush removes precipitated minerals from evaporating chamber
- Easy water level control access

Built-in safety

- CSA/AGA/CGA certified design
- Self-contained infrared gas burners provide safety and reliability
- Gas valves close if the flue becomes blocked, shutting down humidifier operation
- Low-water sensing mechanism with redundant backup shuts down burners in a low water condition
- Can be vented with other Category 1 appliances
- Can interlock with combustion air dampers
- Freeze protection



Next generation control with Vapor-logic4

The heart of any humidification system is its controller. See the next page for the features and benefits of this controller.

DRI-STEEM dispersion: Proven and guaranteed

When it comes to absorption performance, competitors don't come close to DRI-STEEM's proven and guaranteed dispersion systems. Define your dispersion requirements and DRI-STEEM will meet or exceed them. Guaranteed. See Pages 16-23 for more dispersion information.

Save even more energy with our High-Efficiency Tube option

An option for new and existing Ultra-sorb[®] and Rapid-sorb[®] dispersion assemblies, High-Efficiency Tubes provide significant energy savings: Wasted energy is reduced by up to 85%. Airstream heat gain and condensate are also significantly lowered. See Pages 16-17 for more information.



Brave the cold with our heated/ventilated outdoor enclosure

Third-party testers verified that cold temperatures are a breeze for our outdoor enclosures, proven to provide reliable operation under extreme conditions. See Pages 12-13 for more information



Vapor-logic4 controller

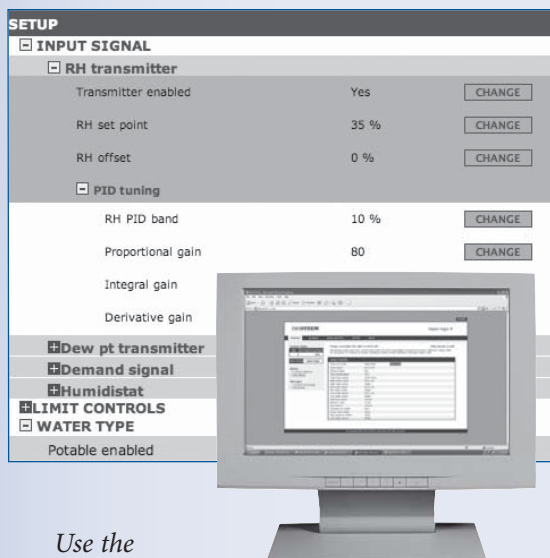

Use the Vapor-logic4 keypad or the standard Web interface, shown here, to control your GTS humidification system.

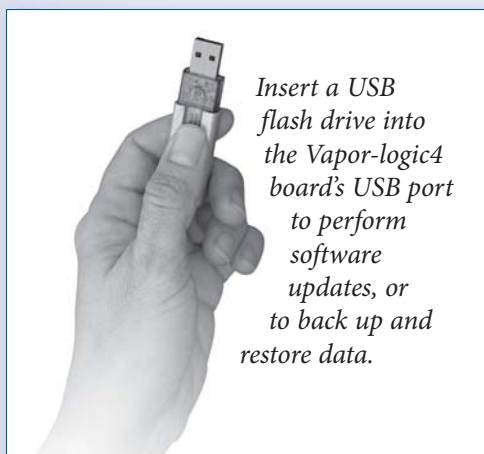

Insert a USB flash drive into the Vapor-logic4 board's USB port to perform software updates, or to back up and restore data.



Accurate, responsive control

Vapor-logic, DRI-STEEM's humidification system controller, has been setting the standard for exceptional functionality and accurate RH control since 1992. The fourth generation controller, Vapor-logic4, retains the qualities that established the Vapor-logic reputation, plus offers several new capabilities, including:

Web interface, a standard feature, enables remote, simultaneous, secure access from anywhere, at any time.

Modbus, BACnet, and LonTalk allow interoperability with multiple building automation systems (BAS).

Up-time optimizer keeps humidifiers operating through system faults, as long as safety conditions are met, minimizing production down-time.

USB port on Vapor-logic4 allows easy software updates, and data backup and restore capability.

PID control provides accurate, responsive, and adjustable relative humidity control.

Real-time clock allows time-stamped alarm and message tracking, and accurate drain and flush scheduling.

Tank temperature sensor, mounted on the evaporating chamber, allows over-temperature protection, freeze protection, and tank preheating, allowing rapid response to a call for humidity.

Auxiliary temperature sensor/transmitter allows temperature compensation control to prevent window condensation, or air temperature monitoring, such as in a duct.

Programmable outputs allow remote signaling or device activation, and are easily configured during the setup process.

Multiple-humidifier control allows staged control of up to 16 humidifiers with one controller.

Enhanced diagnostics include:

- **Test outputs** function, using the keypad or Web interface to verify component operation
- **Test humidifier** function, by simulating demand to validate performance
- **Data collection** of RH, air temperature, water use, energy use, alarms, and service messages for viewing from the keypad or Web interface

Factory commissioning of humidifier and control board guarantees a reliable, fast installation, minimizing field installation requirements. All units are operated and tested — heating water in each tank — before shipping.

Preconfigured but easily changed. Just go into the Setup menu to change a factory setting if, for example, a transmitter changes.

GTS principle of operation

Figure 5-1:
GTS principle of operation

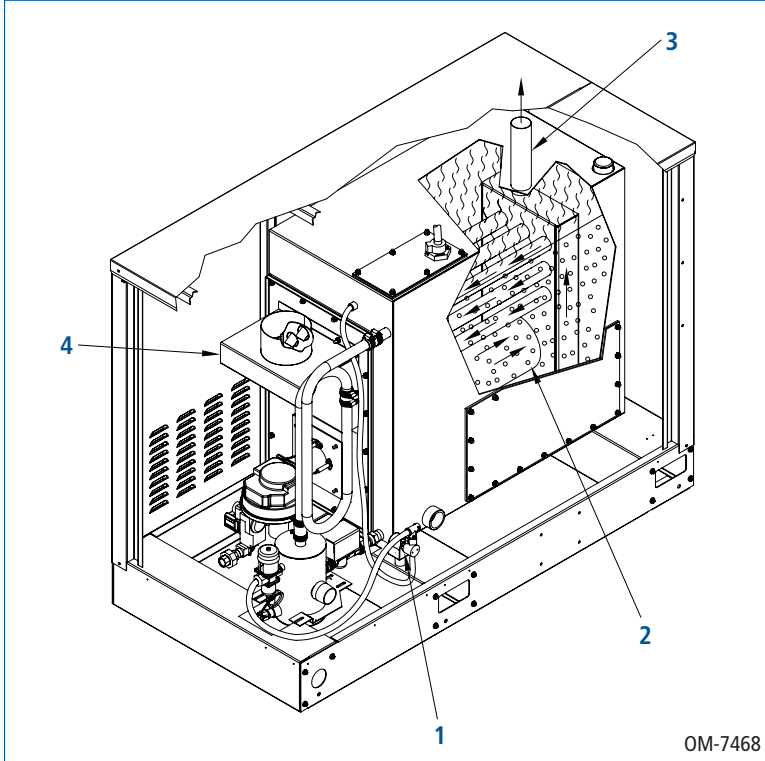

OM-7468

1. When the GTS humidifier is first activated, the fill valve opens and the evaporating chamber fills with water to the operating level.
2. On a call for humidity, the infrared burner(s) ignite(s) sequentially. After all burners are firing into the heat exchanger, the blowers ramp up to bring burners to maximum output until the water in the evaporating chamber boils. The burners then begin to modulate based on demand. The fill valve opens and closes as needed to maintain the operating water level.
3. Steam created in the evaporating chamber flows through vapor hose or piping to the dispersion assembly, where it is discharged into the airstream.
4. The products of combustion are vented out the flue.

GTS components

Figure 6-1:
Water level control for standard water systems

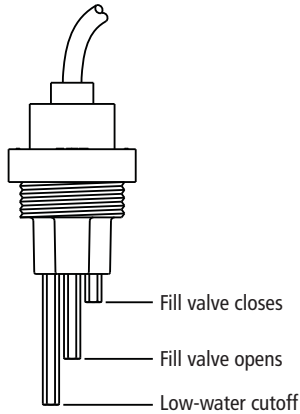

Systems using tap or softened water control water levels electronically using a three-rod probe. The controller responds with the above actions when the water level reaches each rod.

VLC-OM-030

Figure 6-2:
Probe access (with cover open)

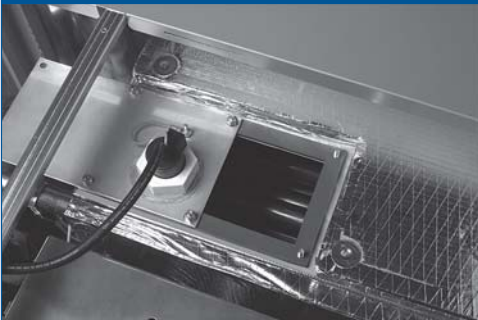
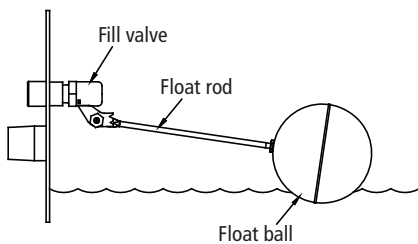
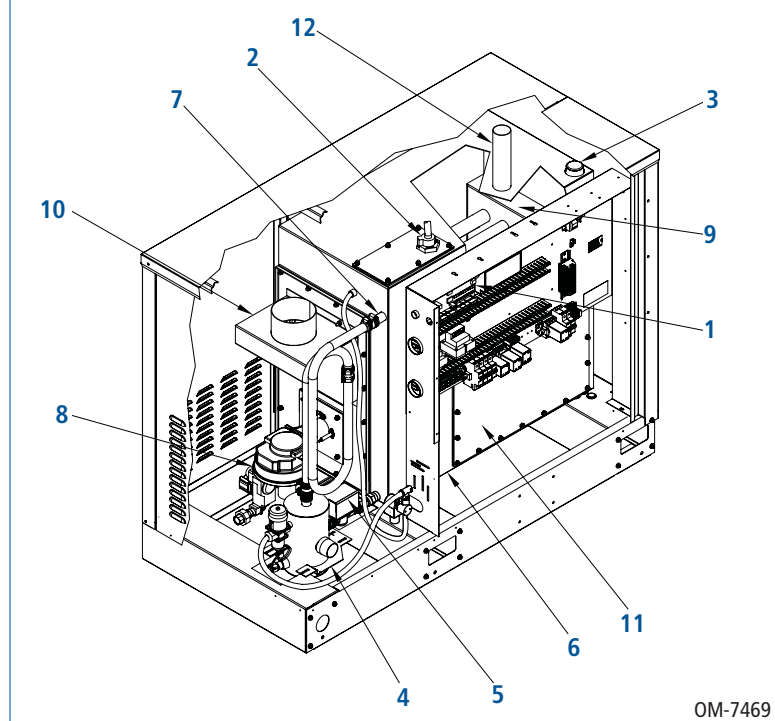

Figure 6-3:
Water level control for DI/RO water systems



VLC-OM-026

Figure 6-4:
GTS components



OM-7469

1. Vapor-logic4 controller (keypad and Web interface not shown)

Vapor-logic4 controls all humidifier functions as a stand-alone controller or integrated into a Modbus, BACnet, or LonTalk system. See Page 4 for more information.

2. Water level control

Tap or softened water systems control water levels electronically using a three-rod probe (Figures 6-1 and 6-2). DI/RO water systems control water levels using a float valve (Figure 6-3) and a low-water cutoff switch.

3. Redundant water sensor

The redundant water sensor provides a safety to the main water level sensor to prevent operation if water is not covering the heat exchanger tubes.

4. Water tempering device

This factory-installed water-tempering device automatically cools discharged hot water to 140 °F (60 °C) to meet governing code requirements for safe discharge water temperature. Cooling discharged hot water also prevents damage to PVC drain piping (see Figure 7-1).

GTS components

5. Drain

Drain duration and frequency can be adjusted through the keypad or Web interface. To avoid possible stagnant water and microbial growth, the humidifier automatically drains if there is no call for humidity after a user-defined time period (72-hour default).

6. Auxiliary drain

This 1½" (DN40) outlet provides an additional location for draining the tank.

7. Water skimmer/overflow port

In standard water systems, the water skimmer reduces minerals in the evaporating chamber. Skimming occurs each time the humidifier fills. The skim time duration is user-adjustable. DI/RO water systems do not require skimming. The skimmer port also functions as an overflow port.

8. Infrared burners

Infrared burners provide fast and efficient heating. The burners have no standing pilot, thus saving energy and improving safety (see Figure 7-1).

9. Heat exchanger

Stainless steel heat exchanger transfers energy from the burners to the water in the evaporating chamber to generate steam.

10. Flue connection

Products of combustion are vented out the flue (see Figure 7-1).

11. Cleanout plate

The cleanout plate allows access for easy removal of settled minerals (see Figure 7-2).

12. Steam outlet

Steam rises and exits through the steam outlet and travels to the dispersion unit through either vapor hose or piping.

Figure 7-1:
View of burner, integral water tempering device, and flue connection

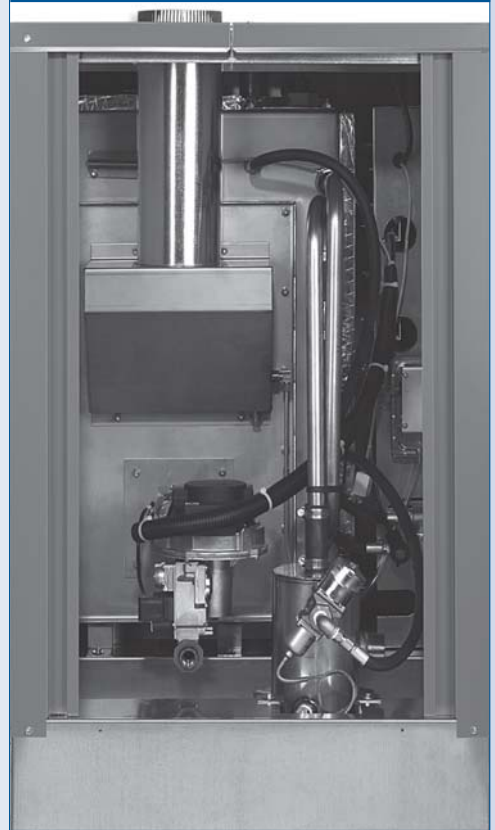

Figure 7-2:
View of keypad, subpanel and cleanout plate



GTS specifications, capacities, and weights

**Table 8-1:
GTS specifications, capacities, and weights**

Model	Number of burners	Maximum steam capacity		Input		Water usage at maximum capacity**		Tank volume		GTS				GTS with outdoor enclosure				Full load amps*
		lbs/hr	kg/h	MBh	kW	gals/hr	litres/hr	gals	litres	Operating weight		Shipping weight		Operating weight		Shipping weight		
										lbs	kg	lbs	kg	lbs	kg	lbs	kg	
GTS-100	1	75	34	100	29	9	34.1	49	185.5	700	320	375	170	800	365	500	230	1.8
GTS-200	1	150	68	200	59	18	68.1	49	185.5	700	320	375	170	800	365	500	230	1.8
GTS-300	2	225	102	300	88	27	102.2	53	200.6	850	385	450	205	1000	455	600	270	3.0
GTS-400	2	300	136	400	117	36	136.3	53	200.6	850	385	450	205	1000	455	600	270	3.0
GTS-500	3	375	170	500	147	45	170.3	76	287.7	1100	500	600	270	1450	660	950	430	4.5
GTS-600	3	450	204	600	176	54	204.4	76	287.7	1100	500	600	270	1450	660	950	430	4.5
GTS-700	4	525	238	700	205	63	238.5	89	336.9	1400	635	700	320	1750	795	1050	475	6.0
GTS-800	4	600	272	800	234	72	272.5	89	336.9	1400	635	700	320	1750	795	1050	475	6.0

Note:

* Add 15 full load amps for outdoor enclosure heater load on all GTS models, add 1 full load amp for an outdoor enclosure without heaters.

** Add 10% to account for skim and automatic drain/flush features if utilized (standard water units only).

**Table 8-2:
High altitude derate**

Altitude		Input derate %
feet	meters	
0–2000	0–610	0
2001–2500	610–765	2*
2501–3000	765–915	4*
3001–3500	915–1065	6*
3501–4000	1065–1220	8*
4001–4500	1220–1370	10
4501–5000	1370–1525	12
5001–5500	1525–1675	14
5501–6000	1675–1830	16
6001–6500	1830–1980	18
6501–7000	1980–2135	20
7001–7500	2135–2285	22
7501–8000	2285–2440	24

Capacity notes

- At sea level, approximately 152 BTUs are required to raise one pound of water from 60 °F to 212 °F. (At sea level, approximately 352 kJ are required to raise one kilogram of water from 16 °C to 100 °C.)
- An additional 970 BTUs are required to change the state of one pound of 212 °F water to vapor. (An additional 2257 kJ are required to change the state of one kilogram of 100 °C water to vapor.)
- Another factor to consider is condensation steam loss from piping. Use the following general steam loss guidelines:
 - Vapor hose: 0.15 lbs/hr/ft (0.22 kg/h/m)
 - Insulated pipe: 0.05 lbs/hr/ft (0.07 kg/h/m)
 - Hard pipe and dispersion tubes: 0.50 lbs/hr/ft (0.7 kg/h/m)
 - High-Efficiency Dispersion Tubes: 0.20 lbs/hr/ft (0.298 kg/h/m)

For more detailed information about condensation steam loss, see the DRI-STEEM Design Guide or our software program, Dri-calc.

LP gas

All models operate at rated MBh/kW input.

High altitude

A derate in MBh/kW input exists when operating units at high altitude. See Table 8-2 for high altitude derate information.

* GTS-400 models are derated 10% from 2001-4500 ft in Canada.

GTS dimensions

**Figure 9-1:
Dimensions**

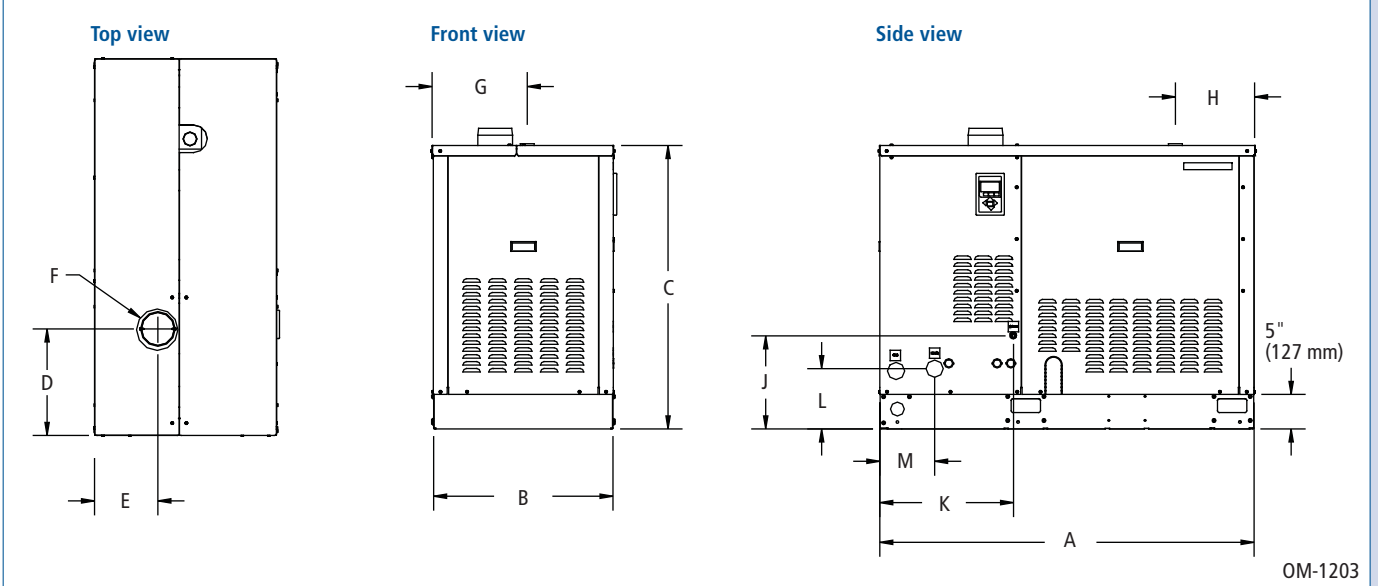
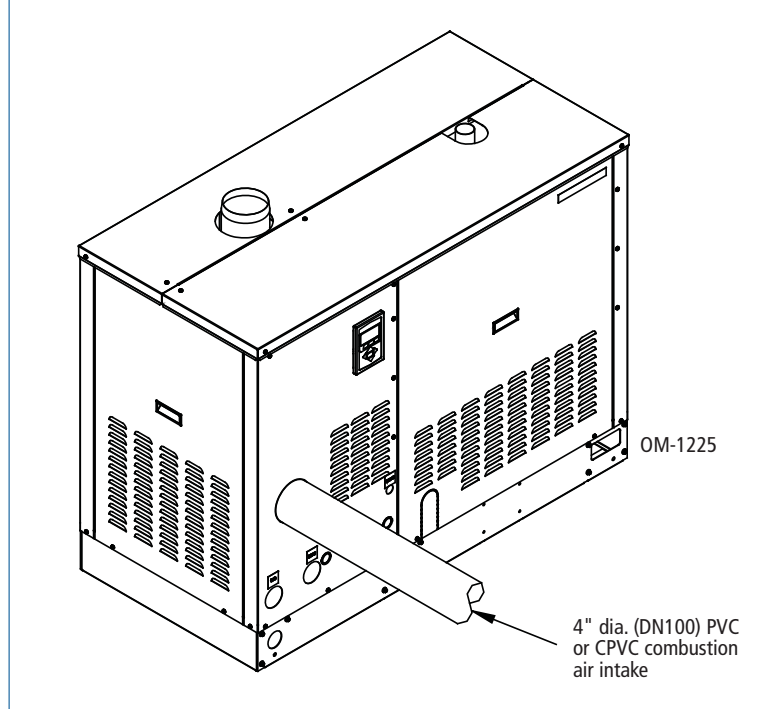

**Table 9-1:
Dimensions**

	Description	GTS-100 GTS-200		GTS-300 GTS-400		GTS-500 GTS-600		GTS-700 GTS-800	
		inches	mm	inches	mm	inches	mm	inches	mm
A	Overall length	54.35	1380	54.35	1380	54.35	1380	54.35	1380
B	Overall width	26.38	670	32.38	822	42.38	1076	48.38	1229
C	Shroud height	41.00	1040	41.00	1040	41.00	1040	41.00	1040
D	Flue position	15.50	394	14.75	375	14.95	375	14.00	356
E		9.13	232	13.13	334	16.63	422	19.13	486
F	Flue diameter	5.00	127	7.00	178	8.00	203	10.00	254
G	Steam outlet position	13.88	353	20.38	518	29.13	740	35.00	889
H		11.63	295	11.63	295	11.63	295	11.63	295
J	Fill valve connection position	13.50	343	13.50	343	13.50	343	13.50	343
K		19.38	492	19.38	492	19.38	492	19.38	492
L	Drain position	8.25	210	8.25	210	8.25	210	8.25	210
M		8.00	203	8.00	203	8.00	203	8.00	203

GTS connection sizes

**Figure 10-1:
GTS optional sealed combustion connection**



**Table 10-1:
Connection sizes**

Description	GTS-100 GTS-200		GTS-300 GTS-400		GTS-500 GTS-600		GTS-700 GTS-800	
	inches	DN	inches	DN	inches	DN	inches	DN
Gas supply	1/2 (pipe thread)	15	1 (pipe thread)	25	1 (pipe thread)	25	1 1/4 (pipe thread)	32
Sealed combustion piping (optional)	4	100	4	100	4	100	4	100
Flue vent	5	125	7	180	8	200	10	250
Water supply to fill valve and tempering device*	3/8 (pipe thread)	10	3/8 (pipe thread)	10	3/8 (pipe thread)	10	3/8 (pipe thread)	10
Drain	1 1/2 (pipe thread)	40	1 1/2 (pipe thread)	40	1 1/2 (pipe thread)	40	1 1/2 (pipe thread)	40
Steam outlet	2 (pipe thread or hose)	50	3 (flange)	80	4 (flange)	100	4 (flange)	100
Condensate return (recommended)	3/4 (pipe thread)	20	3/4 (pipe thread)	20	3/4 (pipe thread)	20	3/4 (pipe thread)	20

Notes:

* In order to minimize DI/RO water use, disconnect factory piping to the water tempering device and pipe directly to tap water.

If planning to use heated supply water, disconnect the water line to the water tempering device at the fill manifold, and reconnect it to a cold water supply. This will ensure that the water tempering device operates properly.

GTS mounting

Mounting

The GTS is available in two mounting configurations:

- Indoor installations: The humidifier is factory-installed in a painted enclosure with integral base.
- Outdoor installations: The humidifier is factory-installed in a galvanized steel enclosure with integral base and includes heaters and ventilation fans. The outdoor enclosure may also be ordered without the heater package, or with a factory-supplied roof curb.

Figure 11-1:
GTS clearance recommendations

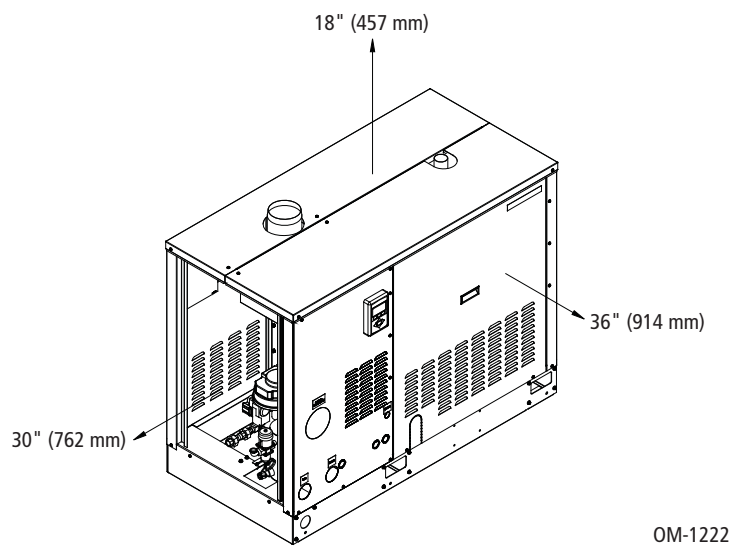

OM-1222

Note:
DRI-STEEM recommends a minimum of 1" (25 mm) clearance between hot surfaces and combustible materials.

Figure 11-2:
GTS only requires two-sided access

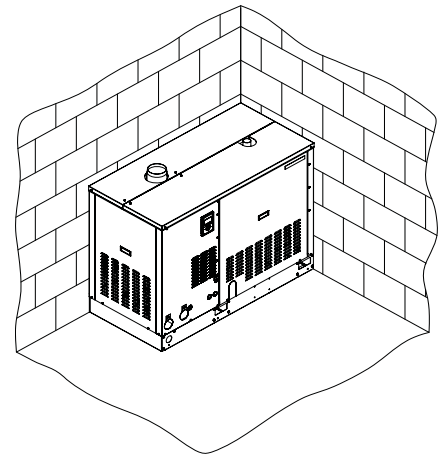

OM-7474

GTS outdoor enclosure



The outdoor enclosure has heating and venting systems that ensure humidifier operation in temperatures from -40°F (-40°C) to 120°F (48°C). The outdoor enclosure can also be ordered without the heater package, or with a factory-supplied curb.

Heated and ventilated outdoor enclosure

DRI-STEEM offers a robust and affordable enclosure for mounting the GTS humidifier outdoors. Independent testing has proven that the GTS installed within this new outdoor enclosure provides error-free ignition and reliable operation under extreme conditions.

The GTS humidifier and outdoor enclosure are assembled at the factory. The unit ships complete to the job site, ready for easy-to-connect gas, water, electrical, and steam field connections.

Outdoor enclosure features

- **Protects in cold and hot climates.** To ensure complete safety and operation in all climates, the outdoor enclosure has heating and venting systems that ensure humidifier operation in temperatures from -40°F (-40°C) to 120°F (48°C). The outdoor enclosure can also be ordered without the heater package.
- **Install on the ground or roof.** The outdoor enclosure is ideal for facilities that have limited interior space.
- **Factory constructed.** The outdoor enclosure ships complete with a GTS unit preinstalled and tested, ready to easily connect to gas, water, steam and electricity.
- **Certified, tested and proven.** GTS humidifiers and outdoor enclosures are CSA/AGA/CGA certified for outdoor operation. In addition, in-house testing has proven that the GTS and outdoor enclosure provide error-free ignition and reliable operation under extreme conditions.
- **Easy service access.** Easily removed panels provide access to all internal components.
- **Robust design.** The outdoor enclosure is ruggedly built to completely protect internal components. The enclosure is constructed of heavy-duty galvanized steel and is fully insulated. Serviceable gaskets on access panels ensure a tight seal.
- **Optional curb.** Factory-supplied curb provides base clearance and allows easy installation.

GTS outdoor enclosure

Figure 13-1:
GTS outdoor enclosure with standard or optional steam outlet, elevation view

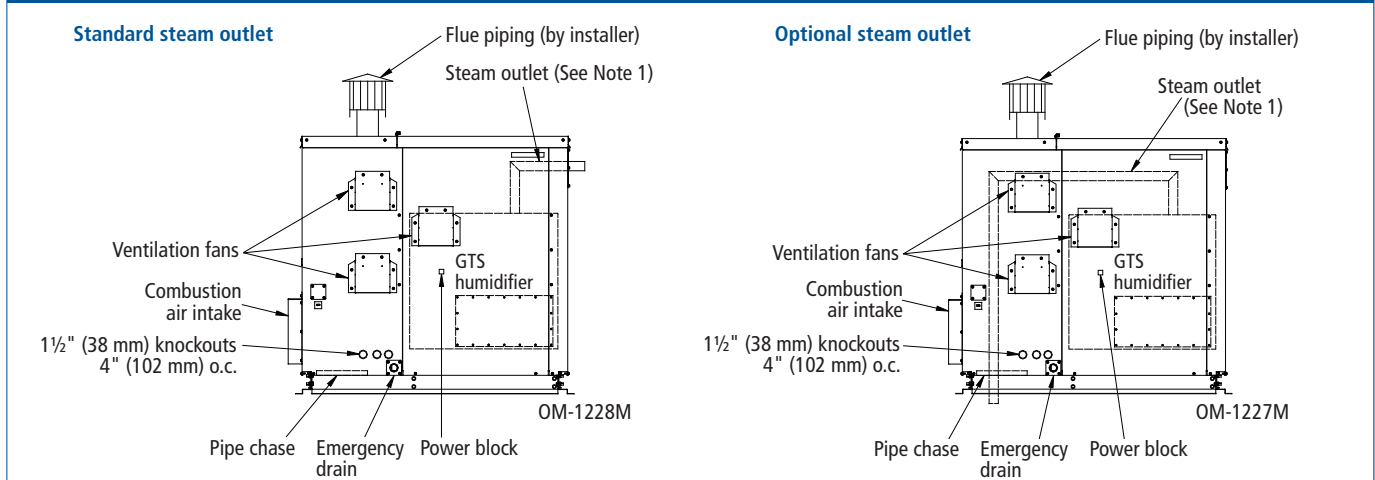

Notes:

1. The outdoor enclosure has two available steam distribution configurations. The standard configuration has a steam outlet at the back of the outdoor enclosure for connecting to steam dispersion unit piping. The optional internal steam distribution configuration routes steam within the outdoor enclosure and down through the enclosure pipe chase into a building.
2. There are three knockouts located on the right and left side of the enclosure. Run the electrical power and gas piping into the enclosure at these knockouts.
3. Piping from the GTS unit to the steam outlet is stainless steel pipe. Piping from the steam outlet to the dispersion assembly is provided by the installer. Choose interconnecting steam piping material that is appropriate for the application (e.g., for high-purity steam applications, consider using stainless steel interconnecting steam piping). See Page 10 for steam outlet sizes.
4. The GTS housed in an outdoor enclosure will operate properly in operating temperatures of -40°F to 120°F (-40°C to 48°C).

Figure 13-2:
Outdoor enclosure mounted on a curb

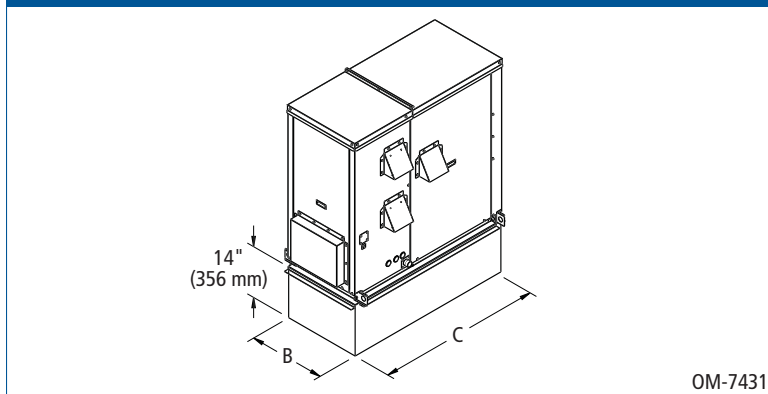

Figure 13-3:
Outdoor enclosure mounted flush

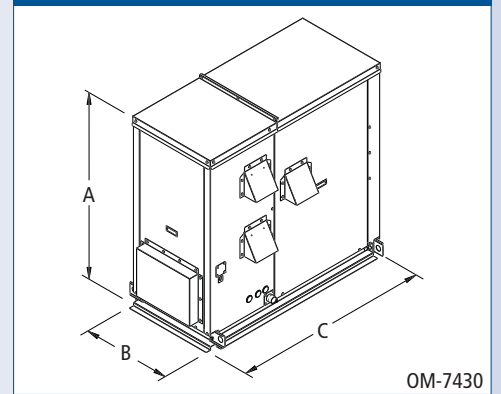
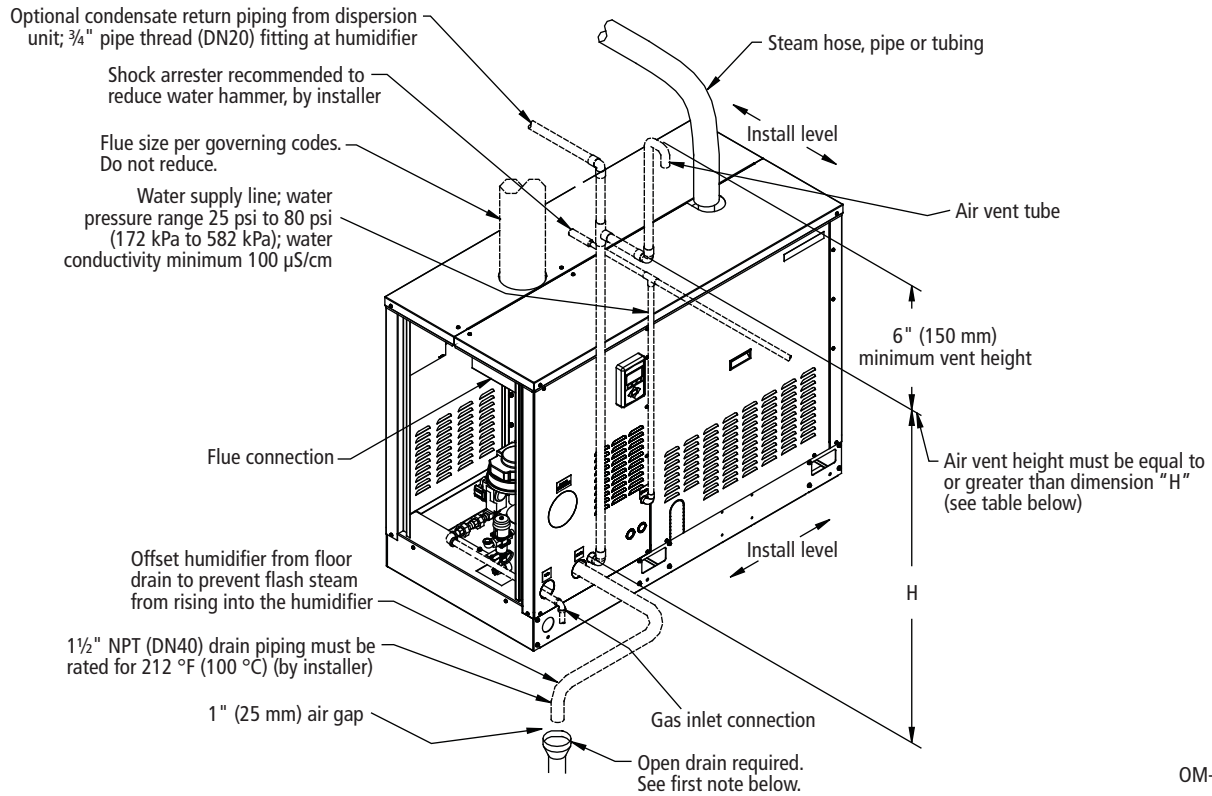

Table 13-1:
Outdoor enclosure dimensions

Description	GTS-100 GTS-200		GTS-300 GTS-400		GTS-500 GTS-600		GTS-700 GTS-800		
	inches	mm	inches	mm	inches	mm	inches	mm	
A	Enclosure height	54.63	1388	54.63	1388	54.63	1388	54.63	1388
B	Enclosure width	26.00	660	32.00	813	42.00	1067	48.00	1219
C	Enclosure length	57.25	1454	57.25	1454	57.25	1454	57.25	1454

GTS piping, standard water models

Figure 14-1:
Field piping overview for GTS standard water models



OM-1208

Notes:

- Locate air gap only in spaces with adequate temperature and air movement to absorb flash steam; otherwise, condensation may form on nearby surfaces. Refer to governing codes for drain pipe size and maximum discharge water temperature.
- Dashed lines indicate provided by installer.
- Humidifier flue gases must be vented to the outside atmosphere.
- The water supply inlet is more than 1" (25 mm) above the skim/overflow port, eliminating the possibility of backflow or siphoning from the tank. No additional backflow prevention is required; however, governing codes prevail.
- Damage caused by chloride corrosion is not covered by your DRI-STEEM warranty.
- See the next page for recommended water supply piping for DI/RO water models.

Table 14-1:
Height required to overcome GTS internal pressure (H)

GTS model number	H = Height required to overcome humidifier internal pressure	
	inches	mm
100, 200	35	889
300, 400, 500, 600, 700, 800	41	1041

GTS piping, DI/RO water models

Figure 15-1:
Field piping overview for GTS DI/RO water models

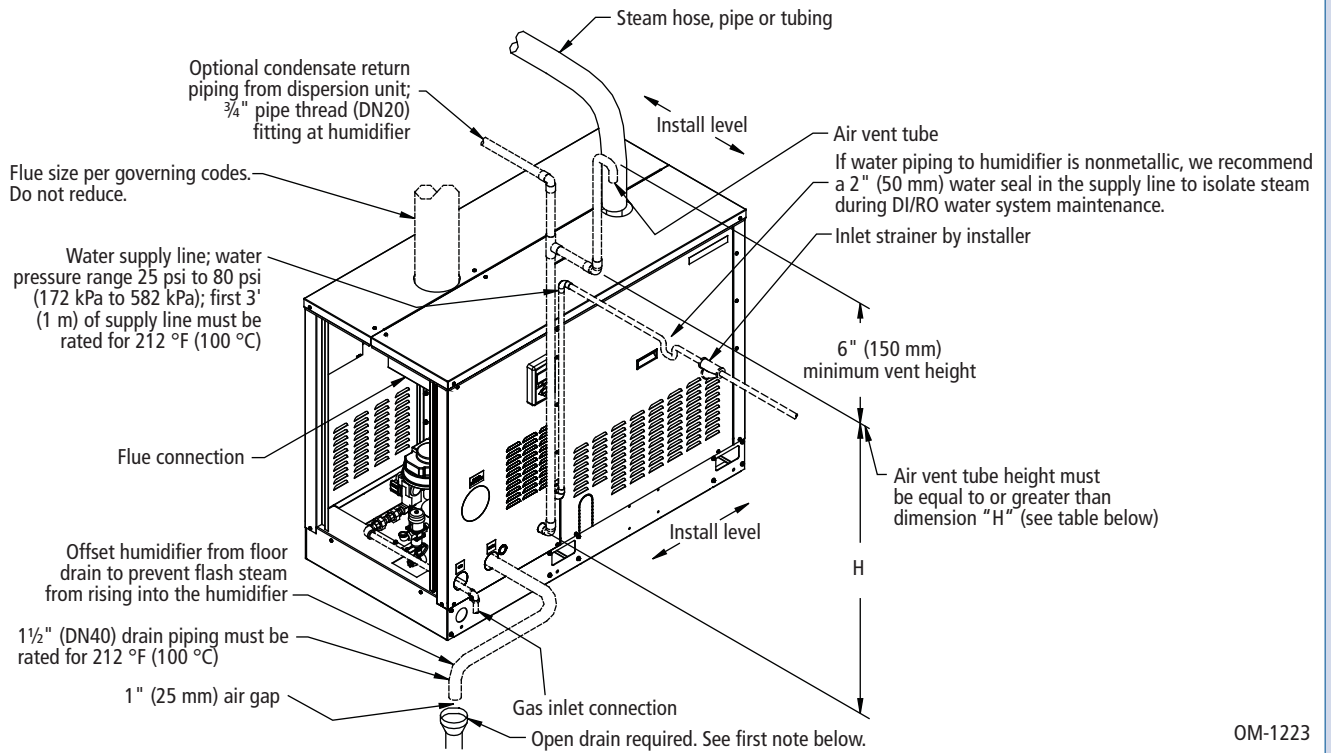

OM-1223

Table 15-1:
Height required to overcome GTS-DI internal pressure (H)

GTS-DI model number	H = Height required to overcome humidifier internal pressure	
	inches	mm
100, 200	35	889
300, 400, 500, 600, 700, 800	41	1041

Notes:

- Locate air gap only in spaces with adequate temperature and air movement to absorb flash steam; otherwise, condensation may form on nearby surfaces. Refer to governing codes for drain pipe size and maximum discharge water temperature.
- Dashed lines indicate piping provided by installer.
- Humidifier flue gases must be vented to the outside atmosphere.
- The water supply inlet is more than 1" (25 mm) above the overflow port, eliminating the possibility of backflow or siphoning from the tank. No additional backflow prevention is required; however, governing codes prevail.
- Damage caused by chloride corrosion is not covered by your DRI-STEEM warranty.
- In order to minimize DI/RO water use, disconnect factory piping to the water tempering device and pipe directly to tap water.
- See the previous page for recommended water supply piping for standard water models.

Drip-free dispersion basics

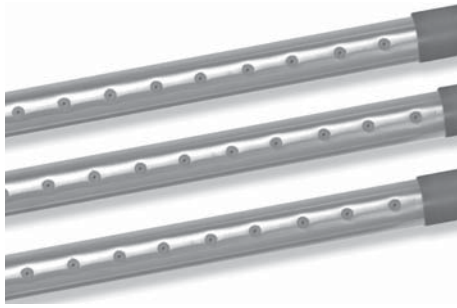

DRI-STEEM's dispersion tubes are fitted with one or two rows of closely-spaced thermal-resin tubelets to evenly disperse steam across the airstream.

Guaranteed non-wetting distances

Using data collected in our on-site test laboratories, we have developed guaranteed steam absorption (non-wetting) distances, allowing you to confidently choose equipment that will accommodate any application.

Dry steam

Adding humidification to an airstream without creating wetness in the duct system is critical for the maintenance of a healthy environment. Wet areas in ducts are a threat to the health of building occupants since they moisten dust on duct floors, creating ideal breeding grounds for disease-producing microbes. In addition, water accumulating in ducts can drip and cause building damage.

Steam exits drip-free through tubelets

All DRI-STEEM evaporative dispersion tube units discharge steam through thermal-resin tubelets fitted into dispersion tubes. These tubelets extend from the center of the tube, where the steam is driest, through the tube wall, to the duct airstream. In essence, the tubelets provide a temperature-neutral exit tunnel for steam, allowing steam to cross over lower-temperature metal without condensing or dripping. Each tubelet contains a calibrated orifice sized for steam capacity. These tubelets are a DRI-STEEM exclusive, and are essential for drip-free steam dispersion.

Condensate management

Some condensation is inevitable in steam dispersion, but through careful design condensate can be managed.

For example, Ultra-sorb Models LV and LH use gravity to remove condensate. Steam enters the supply header, exits through the tubelets, and condensate drains out the return header. Ultra-sorb Model XV, available with STS humidifiers, has a heat exchanger that vaporizes dispersion-generated condensate.

Rapid-sorb dispersion units manage velocities to ensure condensate is not pushed out into the air along with steam but drains out the opposite end of the header.

Reduce condensate, wasted energy with High-Efficiency Tubes

To significantly reduce condensate and wasted energy, use DRI-STEEM's High-Efficiency Tubes, which reduce dispersion-generated condensate and wasted energy by up to 85%. See our *High-Efficiency Tube option* described in more detail on Page 17.

GTS steam dispersion options

Ultra-sorb Models LV and LH

Most versatile

- Guaranteed, short non-wetting distances — install within inches of downstream devices
- Reduce wasted energy up to 85% and increase capacity with optional High-Efficiency Dispersion Tubes
- Lowest installation cost — factory assembly for easy installation

Capacity:

Up to 1850 lbs/hr (840 kg/h) per panel

High-Efficiency Dispersion Tubes option

For new and existing Ultra-sorb, Rapid-sorb, single dispersion tube

- Highest efficiency
- Increases tube capacity up to 6 lbs/hr (2.7 kg/h)
- Up to 85% reduction in wasted energy, airstream heat gain, and condensate production
- Plenum approved for in-duct installation



Ultra-sorb Models LV



Ultra-sorb Model LH

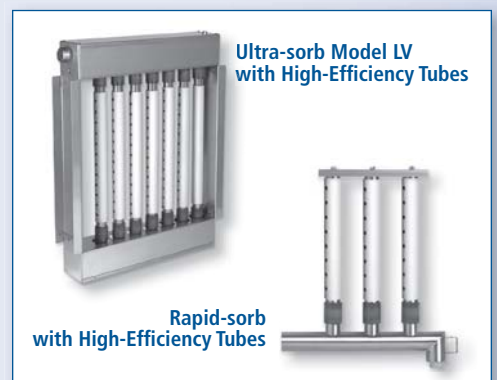

Ultra-sorb Model LV
with High-Efficiency Tubes

Rapid-sorb
with High-Efficiency Tubes

GTS steam dispersion options

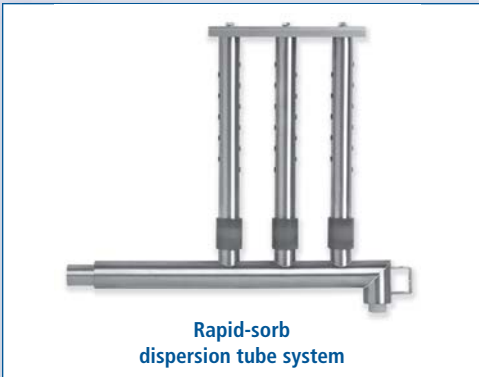

Rapid-sorb
dispersion tube system

Rapid-sorb® dispersion tube system

Multiple tubes, short non-wetting distance

- Short non-wetting distance, compared to single dispersion tube
- Horizontal or vertical airflows
- Install Rapid-sorb header inside or outside duct
- Available with High-Efficiency Dispersion Tubes

Capacity: Up to 2100 lbs/hr (955 kg/h) per system



Single dispersion tube

Single dispersion tube

Installation flexibility

- Low-capacity dispersion for horizontal or vertical airflows.
- Available as a High-Efficiency Dispersion Tube

Capacity: Up to 97 lbs/hr (38 kg/h)

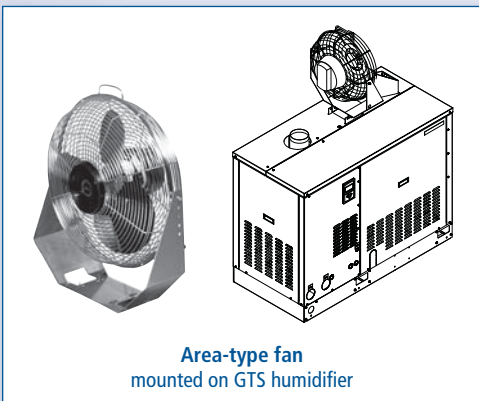

Area-type fan
mounted on GTS humidifier

Area-type fan

Quiet steam dispersion for open spaces

- Mounts directly on top of GTS humidifier

Capacity: Up to 300 lbs/hr (136 kg/h)

Ultra-sorb Model LV

**Figure 19-1:
Ultra-sorb Model LV dimensions**

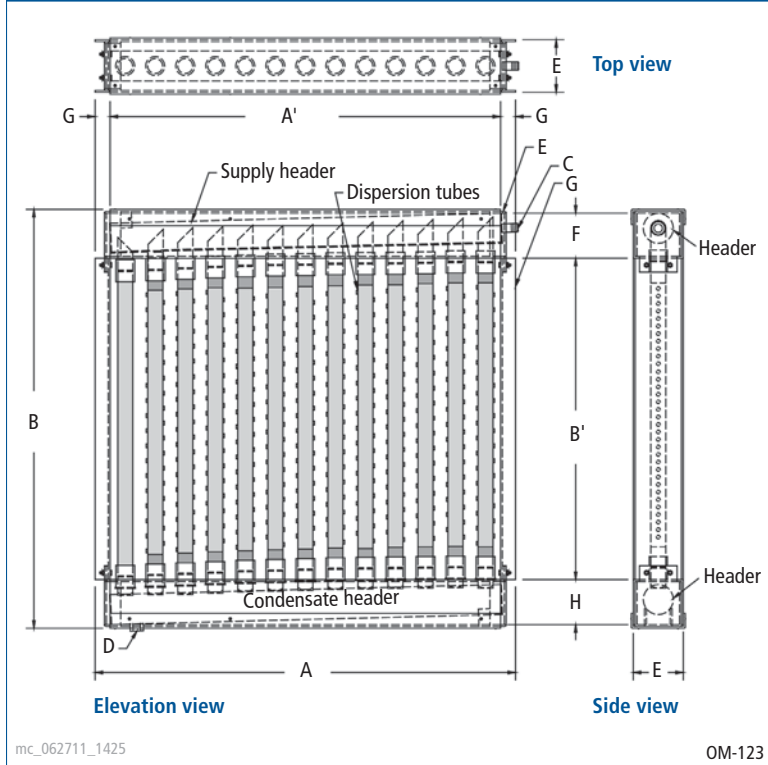

**Table 19-1:
Ultra-sorb Model LV and LH
tube capacity***

Insulated		Uninsulated	
lbs/hr	kg/h	lbs/hr	kg/h
86	39	80	36

Note:

* For Model LV, if face height is <26" (660 mm), tube quantity per panel may need to increase to compensate for reduced capacity of short tubes. For Model LH, if face width is <25" (635 mm), tube quantity per panel may need to increase to compensate for reduced capacity of short tubes.

Consult DRI-STEEM or see Dri-calc for the correct calculation.

mc_010709_0710

Notes:

- For more information about Ultra-sorb, see the [Ultra-sorb catalog](#) or DRI-STEEM's [Dri-calc software](#).

**Table 19-2:
Ultra-sorb Model LV dimensions**

A Unit width	15" (380 mm) min, 147" (3735 mm) max, in 1" (25 mm) increments
A' Face width	12" (305 mm) min, 144" (3660 mm) max, in 1" (25 mm) increments
B Unit height	21" (530 mm) min, 156" (3960 mm) max, in 1" (25 mm) increments Shipped unassembled by request or if unit height is more than 98" (2490 mm)
B Face height	12" (305 mm) min, 144" (3660 mm) max, in 1" (25 mm) increments
C Steam inlet diameter	Determined by maximum steam capacity
D Condensate drain	3/4" pipe thread (DN20)
E Header enclosure (front to back)	For 3" (DN80) and 4" (DN100) headers, E = 5" (127 mm); for 5" (DN125) header, E = 6" (152 mm); for 6" (DN150) header, E = 7" (178 mm)
F Header enclosure (top to bottom)	For 3" (DN80) header F = 4.5" (114 mm); for 4" (DN100) header, F = 5.5" (140 mm); for 5" (DN125) header, F = 6.5" (165 mm); for 6" (DN150) header F = 7.5" (191 mm)
G Mounting flange	1.5" (38 mm)
H Condensate header enclosure	4.5" (114 mm)

Note: Header dimensions are determined by capacity. See Table 20-1.

mc_050808_1215

Ultra-sorb Model LH

**Table 20-1:
Nonpressurized steam header capacities**

Header capacity		Header diameter	
lbs/hr	kg/h	inches	DN
300	135	3	80
600	270	4	100
1100	500	5	125
1850	820	6	150

mc_062711_1426

Notes:

- When connected to a GTS humidifier install Ultra-sorb Model LH in vertical airflows only.
- For more information about Ultra-sorb, see the [Ultra-sorb catalog](#) or DRI-STEEM's [Dri-calc software](#).

**Figure 20-1:
Ultra-sorb Model LH dimensions**

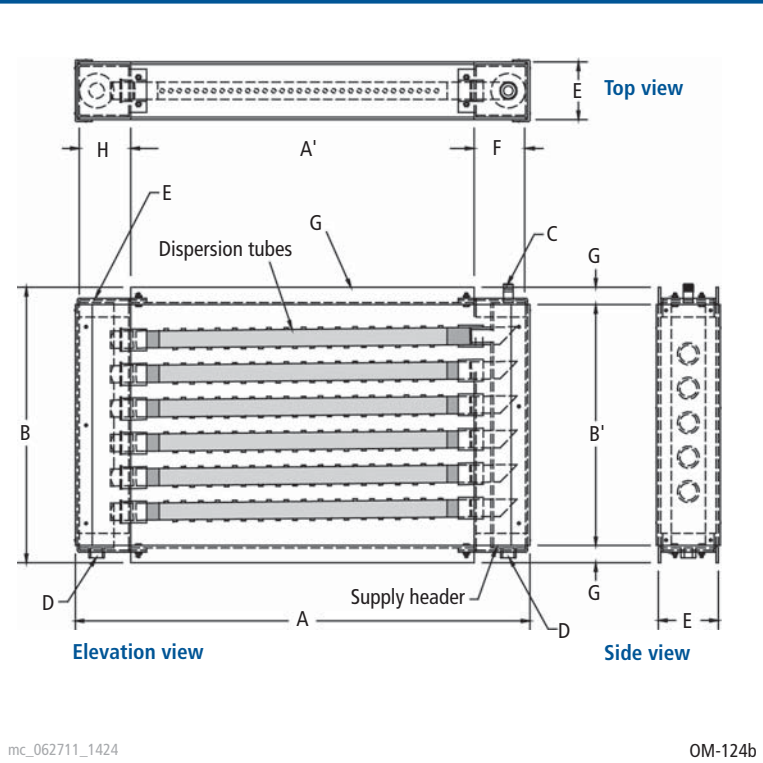

mc_062711_1424

OM-124b

**Table 20-3:
Ultra-sorb Model LH dimensions**

A Unit width	21" (530 mm) min, 129" (3280 mm) max, in 1" (25 mm) increments
A' Face width	12" (305 mm) min, 120" (3050 mm) max, in 1" (25 mm) increments
B Unit height	15" (380 mm) min, 123" (3125 mm) max, in 1" (25 mm) increments Shipped unassembled by request or if unit height is more than 98" (2490 mm)
B' Face height	12" (305 mm) min, 120" (3050 mm) max, in 1" (25 mm) increments
C Steam inlet diameter	Determined by maximum steam capacity
D Condensate drain	3/4" pipe thread (DN20)
E Header enclosure (front to back)	For 3" (DN80) and 4" (DN100) headers, E = 5" (127 mm); for 5" (DN125) header, E = 6" (152 mm); for 6" (DN150) header, E = 7" (178 mm)
F Header enclosure (top to bottom)	For 3" (DN80) header, F = 4.5" (114 mm); for 4" (DN100) header, F = 5.5" (140 mm); for 5" (DN125) header, F = 6.5" (165 mm); for 6" (DN150) header, F = 7.5" (191 mm)
G Mounting flange	1.5" (38 mm)
H Condensate header enclosure	4.5" (114 mm)

Note: Header dimensions are determined by capacity. See Table 20-1.

mc_062711_1430

Rapid-sorb dispersion

**Figure 21-1:
Rapid-sorb dimensions**

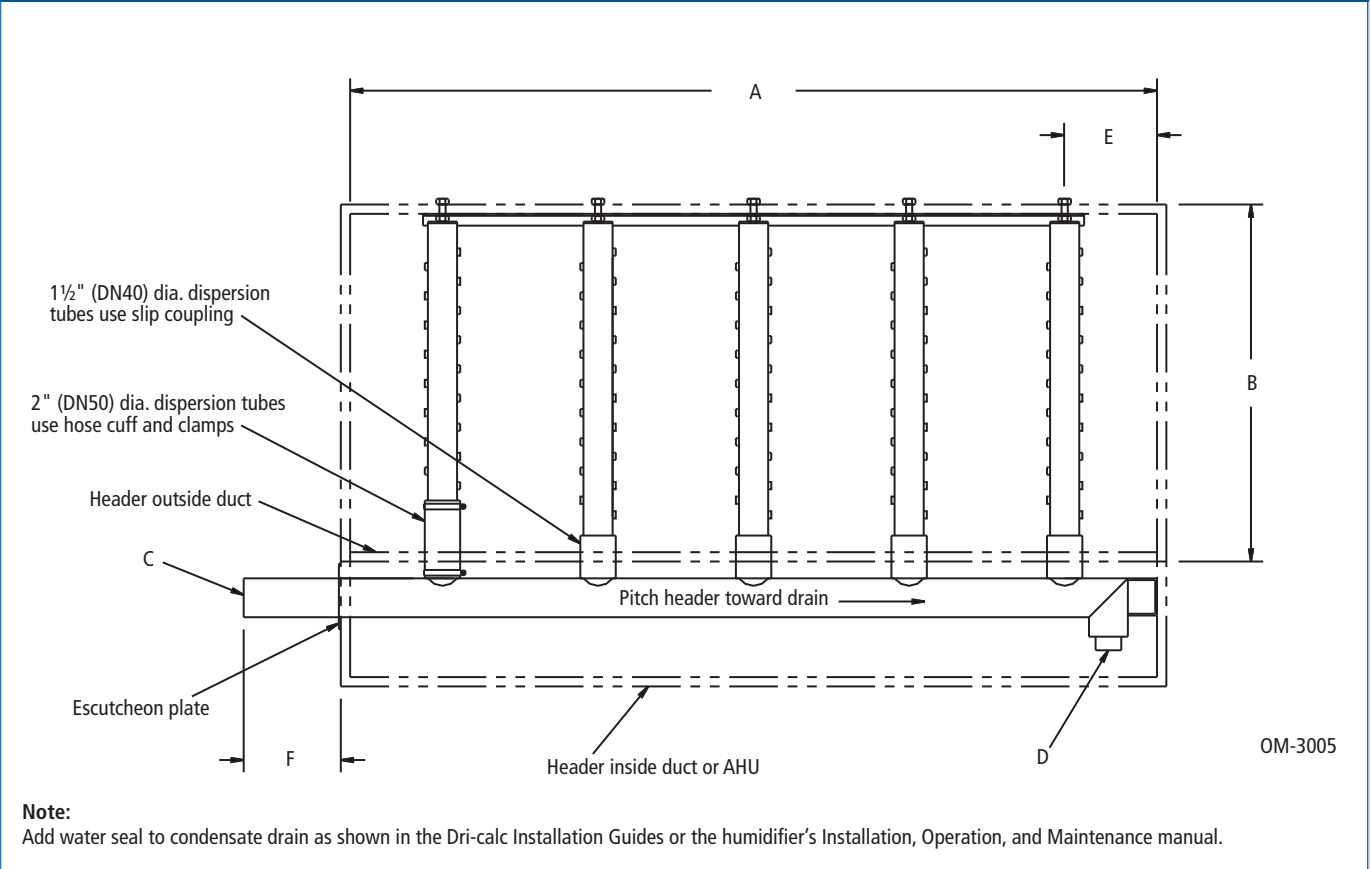

**Table 21-1:
Rapid-sorb dimensions**

Dimension	Description	Inches (mm)
A	Face width	12" (305) minimum to 120" (3048) maximum in 1" (25) increments
B	Face height	12" (305) minimum to 120" (3048) maximum in 1" (25) increments
C	Steam inlet	Determined by humidifier maximum capacity
D	Condensate drain	3/4" pipe thread (DN20)
E	Distance from tube center to inside of duct or AHU wall	4.5" (114) minimum
F	Distance from outside of duct or AHU wall to end of Rapid-sorb leader	4.5" (114) minimum

Note:
All Rapid-sorb units are custom-sized and field-assembled to fit the duct or air handler. Consult DRI-STEEM for sizes larger or smaller than those listed above.

**Table 21-2:
Rapid-sorb tube capacities***

Tube diameter		Insulated (High-Efficiency Tubes)		Uninsulated	
inches	DN	lbs/hr	kg/h	lbs/hr	kg/h
1 1/2	40	43	19.5	40	18.2
2	50	80	36.4	77	35

Note:
* Capacities shown are for horizontal airflow. See Dri-calc for vertical airflow capacities. If face height is <22" (559 mm), tube quantity per panel may need to increase to compensate for reduced capacity of short tubes. Consult DRI-STEEM or see Dri-calc for the correct calculation.

mc_121311_1321

Single dispersion tube

Figure 22-1:
Single dispersion tube without and with condensate drain

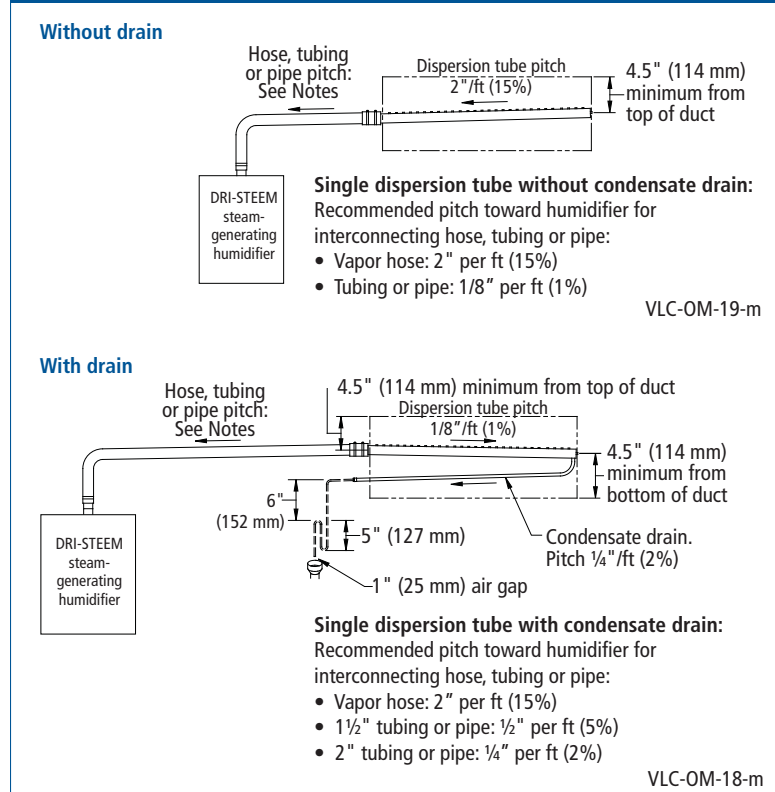

Table 22-1:
Single dispersion tube capacities*

Tube size		Insulated (High-Efficiency Tubes)				Uninsulated			
		Without drain		With drain		Without drain		With drain	
inches	DN	lbs/hr	kg/h	lbs/hr	kg/h	lbs/hr	kg/h	lbs/hr	kg/h
1 1/2	40	29	13.2	65	29.5	28	12.7	62	28.2
2	50	65	29.5	97	44.1	62	28.2	93	42.3

Notes:

- * If face width is <19" (483 mm), tube capacity could be reduced. Consult DRI-STEEM or see Dri-calc for the correct capacity.
- Single dispersion tubes are available with face width between 6" (152 mm) and 120" (3048 mm) in 1" (25 mm) increments.

mc_121311_1337

Area-type dispersion

Table 23-1:
Area-type (evaporative steam) minimum non-wetting distances*

Maximum steam capacity		60 °F (16 °C)																	
		30% RH						40% RH						50% RH					
		Rise		Spread		Throw		Rise		Spread		Throw		Rise		Spread		Throw	
lbs/hr	kg/h	ft	m	ft	m	ft	m	ft	m	ft	m	ft	m	ft	m	ft	m	ft	m
50	20	1.0	0.3	2.0	0.6	6.0	1.8	1.0	0.3	2.0	0.6	6.0	1.8	1.0	0.3	2.5	0.8	6.0	1.8
75	34	3.0	0.9	3.0	0.9	8.0	2.4	3.0	0.9	3.0	0.9	8.0	2.4	3.0	0.9	4.0	1.2	8.0	2.4
100	45	4.0	1.2	4.0	1.2	10.0	3.1	4.0	1.2	4.0	1.2	10.0	3.1	4.0	1.2	5.0	1.5	10.0	3.1
150	68	6.0	1.8	5.0	1.5	12.0	3.7	6.0	1.8	5.0	1.5	12.0	3.7	6.0	1.8	5.0	1.5	12.0	3.7
200	90	7.0	2.1	7.0	2.1	13.0	4.0	8.0	2.4	7.0	2.1	14.0	4.3	8.0	2.4	7.0	2.1	14.0	4.3
225	102	7.0	2.1	7.0	2.1	13.0	4.0	8.0	2.4	7.0	2.1	14.0	4.3	8.0	2.4	7.0	2.1	14.0	4.3
250	110	8.0	2.4	8.0	2.4	15.0	4.6	9.0	2.7	9.0	2.7	16.0	4.9	9.0	2.7	9.0	2.7	16.0	4.9
285	130	9.0	2.7	9.0	2.7	17.0	5.2	10.0	3.1	10.0	3.1	18.0	5.5	10.0	3.1	10.0	3.1	18.0	5.5
300	136	9.0	2.7	9.0	2.7	17.0	5.2	10.0	3.1	10.0	3.1	18.0	5.5	10.0	3.1	10.0	3.1	18.0	5.5

Maximum steam capacity		70 °F (16 °C)																	
		30% RH						40% RH						50% RH					
		Rise		Spread		Throw		Rise		Spread		Throw		Rise		Spread		Throw	
lbs/hr	kg/h	ft	m	ft	m	ft	m	ft	m	ft	m	ft	m	ft	m	ft	m	ft	m
50	20	1.0	0.3	1.5	0.5	4.0	1.2	1.0	0.3	2.0	0.6	4.0	1.2	1.0	0.3	2.0	0.6	4.0	1.2
75	34	2.0	0.6	2.0	0.6	6.0	1.8	2.0	0.6	2.5	0.8	6.0	1.8	2.0	0.6	2.5	0.8	6.0	1.8
100	45	3.0	0.9	3.0	0.9	8.0	2.4	3.0	0.9	3.0	0.9	8.0	2.4	3.0	0.9	3.0	0.9	8.0	2.4
150	68	4.0	1.2	4.0	1.2	10.0	3.1	4.0	1.2	4.0	1.2	11.0	3.4	4.0	1.2	4.0	1.2	11.0	3.4
200	90	5.0	1.5	5.0	1.5	11.0	3.4	5.0	1.5	5.0	1.5	12.0	3.7	5.0	1.5	5.0	1.5	12.0	3.7
225	102	5.0	1.5	5.0	1.5	11.0	3.4	5.0	1.5	5.0	1.5	12.0	3.7	5.0	1.5	5.0	1.5	12.0	3.7
250	110	6.0	1.8	6.0	1.8	12.0	3.7	6.0	1.8	6.0	1.8	13.0	4.0	6.0	1.8	6.0	1.8	14.0	4.3
285	130	7.0	2.1	7.0	2.1	14.0	4.3	7.0	2.1	7.0	2.1	15.0	4.6	7.0	2.1	7.0	2.1	16.0	4.9
300	136	7.0	2.1	7.0	2.1	14.0	4.3	7.0	2.1	7.0	2.1	15.0	4.6	7.0	2.1	7.0	2.1	16.0	4.9

Notes:

* With fan on high speed

Rise: Minimum non-wetting height above the steam chute

Spread: Minimum non-wetting width from the steam chute

Throw: Minimum non-wetting horizontal distance from the steam chute

Fan specifications:

Motor: 120 V, 50/60 Hz

Speeds: 3

Control: Rotary switch

cfm: 5350 (high speed)

m³/s: 2.52 (high speed)

rpm: 1500 (high speed)

Amps: 1.52 (high speed)

Figure 23-1:
Area-type rise, spread, throw

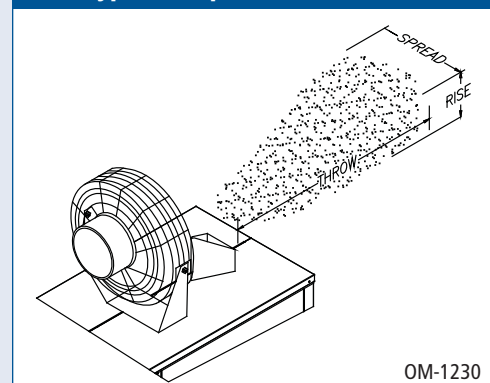

OM-1230

Conserving resources through better performance

Expect quality from the industry leader

For more than 45 years, DRI-STEEM has been leading the industry with creative and reliable humidification solutions. Our focus on quality is evident in the construction of the GTS humidifier, which features cleanable, stainless steel construction. DRI-STEEM also leads the industry with a Two-year Limited Warranty and optional extended warranty.

For more information

www.dristeem.com
sales@dristeem.com

For the most recent product information visit our website:

www.dristeem.com

DRI-STEEM Corporation

An ISO 9001:2000 certified company

U.S. Headquarters:
14949 Technology Drive
Eden Prairie, MN 55344
800-328-4447 or 952-949-2415
952-229-3200 (fax)

European office:
Marc Briens
Grote Hellekensstraat 54 b
B-3520 Zonhoven
Belgium
+3211823595 (voice)
+3211817948 (fax)
E-mail: marc.briens@dristeem.com

Continuous product improvement is a policy of DRI-STEEM Corporation; therefore, product features and specifications are subject to change without notice.

DRI-STEEM, Dri-calc, Rapid-sorb, Ultra-sorb, Vapor-logic, and Vaporstream are registered trademarks of DRI-STEEM Corporation and are filed for trademark registration in Canada and the European community.

Area-type and Drane-kooler are trademarks of DRI-STEEM Corporation.

Product and corporate names used in this document may be trademarks or registered trademarks. They are used for explanation only without intent to infringe.

© 2011 DRI-STEEM Corporation



Form No. GTS-CAT-1211

DRI-STEEM conserves resources by designing humidification systems that optimize performance. Systems that perform well save energy and water and, ultimately, cost less to operate and maintain.

Save energy

For applications requiring short absorption, High-Efficiency Dispersion Tubes reduce wasted energy up to 85% by significantly reducing airstream heat gain and condensate production. Available for new and retrofit Ultra-sorb® and Rapid-sorb® steam dispersion panels.



DRI-STEEM's High-Pressure Atomizing Systems disperse unheated micro-fine water particles into airstreams or open spaces. As atomized water droplets evaporate, air temperature drops, reducing the cooling load. This provides significant energy savings when humidifying and cooling simultaneously.



Save water

Ultra-sorb Model XV eliminates water waste and reduces airstream heat gain, energy costs, and boiler chemical use. Available for STS® steam-to-steam humidifiers and all pressurized steam applications.

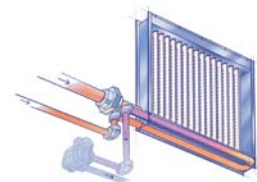

Optimize performance

DRI-STEEM's most advanced controller, Vapor-logic®4 continuously monitors space conditions to align humidifier output with demand. The result is accurate, responsive control.



Your DRI-STEEM representative is:

