DRISTEEM[®]
The humidification experts

Drane-kooler[™]

Water Tempering Device

**Installation, Operation,
and Maintenance Manual**



Table of contents

Overview

Features Summary	3
Capacities and connection sizes	4
Dimensions	5

Installation

Installation instructions	6
Mounting	7
Piping	8

Operation

Start-up and operation instructions	9
---	---

Maintenance/Troubleshooting

Maintenance and troubleshooting	10
---------------------------------------	----

Replacement parts

Replacement parts	11
-------------------------	----

Warranty

.....	Back cover
-------	------------

Features summary

Cool discharged hot water

Drane-kooler is a water tempering device that mixes cold water with hot water discharged from various types of equipment, such as a humidifier, to reduce the discharged water temperature before it enters a municipal sewer system.

There are two reasons to use a water tempering device. First, most municipalities prohibit draining water hotter than 140 °F (60 °C) into their sewer systems. And second, PVC drain pipes are susceptible to damage from water that is too hot. When faced with either of these situations, Drane-kooler is the solution!

Horizontal design

A space-efficient horizontal orientation and side drain outlet provide enough clearance to allow the Drane-kooler to be mounted directly underneath DRI-STEEM humidifiers, saving footprint space while allowing room for pitched drain piping.

How it works: hot + cold = tempered!

1. Hot water discharged from a humidifier or other appliance enters the Drane-kooler through piping connected to the top threaded connection. A vacuum breaker prevents backflow into potable water systems.
2. Cold water enters through the temperature-actuated valve. The valve and the Drane-kooler's straightforward design ensure efficient mixing of hot and cold water. The valve's sensor, located near the outlet, ensures that water leaving the Drane-kooler is 140 °F (60 °C) or less before entering the municipal sewer system.
3. Tempered water at 140 °F (60 °C) or less exits through the side outlet for safe discharge into a municipal sewer system or PVC pipe.

Reliable, non-electric valve

The temperature-actuated valve is time-tested to be reliable and maintenance-free. And because it is non-electric, no wiring is required!

Multiple mounting options

The Drane-kooler can be mounted by attaching the integral mounting plate to a wall, by attaching the mounting plate to an adjustable floor stand, or by using an assembly for suspension mounting. These multiple mounting options provide capability for the Drane-kooler to be properly supported and not secured entirely by piping.

**Figure 3-1:
Drane-kooler**

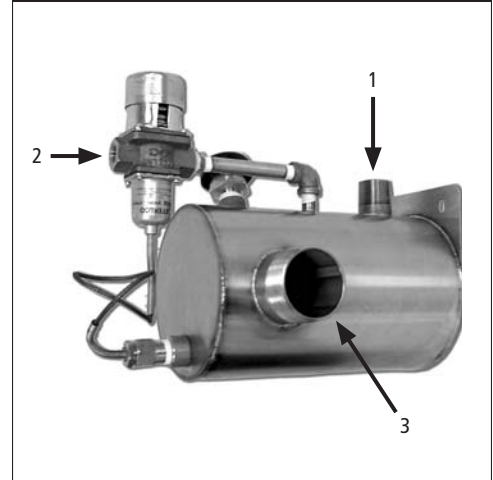

Capacities and connection sizes

**Figure 4-1:
Optional floor mount piping example**

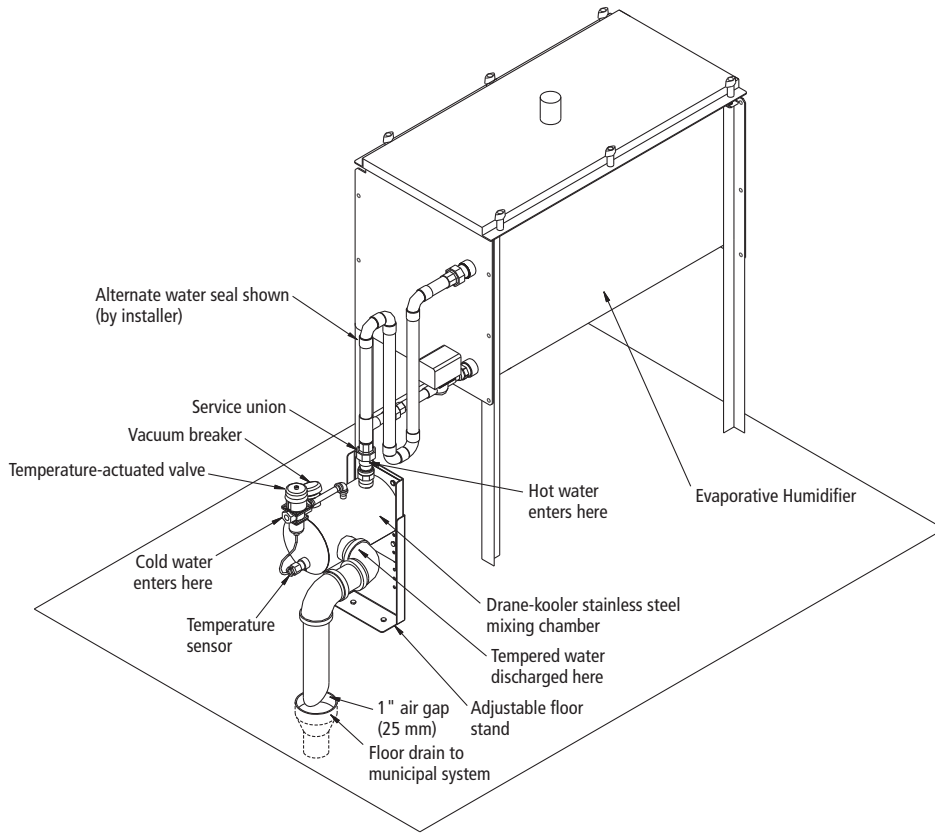

OM-1117

**Table 4-1:
Drane-kooler connections**

Hot water inlet connection	1" (DN25) pipe thread
Tempered water outlet connection	2" (DN50) pipe thread
Cold water supply connection	3/8" (DN10) pipe thread

**Table 4-2:
Drane-kooler capacities***

	Maximum flow rate		Maximum temperature	
	U.S. gpm	L/m	°F	°C
Hot water inflow	6	22.7	212	100
Cold water inflow**	6	22.7	70	21
Tempered water outflow	12	45.4	140	60

Note:

* This table applies only if one humidifier is connected to one Drane-kooler, with no more than 10' (3m) of vertical dimension between the Drane-kooler and the humidifier.

** Cold water inflow pressure must be between 25 psi and 80 psi (172 kPa and 552 kPa).

Drane-kooler dimensions

**Figure 5-1:
Drane-kooler dimensions**

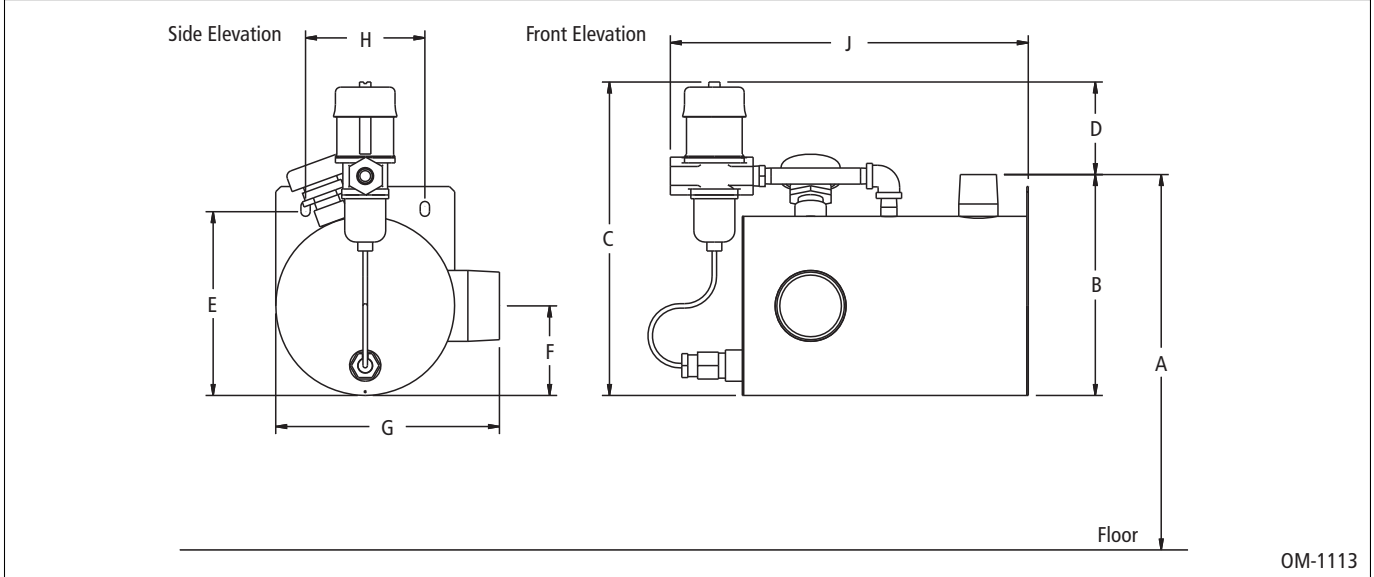

OM-1113

**Table 5-1:
Drane-kooler dimensions**

	Description	inches	mm
A	Height with floor stand (from floor to top of hot water inlet in 1" [25 mm] increments)	8.25 to 12.25	210 to 312
	Height with floor stand and extension (from floor to top of hot water inlet in 1" [25 mm] increments)	13.25 to 20.25	337 to 515
B	Height from bottom of tank to top of hot water inlet	7.5	191
C	Height from bottom of tank to top of valve	10.5	268
D	Height from top of hot water inlet to top of valve	3.0	76
E	Height from bottom of tank to center of mounting hole	6.25	159
F	Height from bottom of tank to center of tempered water outlet	3.0	76
G	Width of tank and tempered water outlet	7.5	191
H	Width of mounting plate holes, center to center	4.0	102
J	Length, from valve inlet to mounting plate	12.0	305

Installation instructions

Step-by-step installation instructions

1. Verify that maximum flow of hot water into the Drane-kooler does not exceed 6 U.S. gallons per minute (gpm) (22.7 L/m).
2. Note that there are three connections to be made to the Drane-kooler:
 - Cold water supply
 - Hot water inlet (from a humidifier or other appliance)
 - Tempered water piping to drain
3. Position the Drane-kooler to allow the most direct path of piping to minimize fittings (see the piping diagrams on Pages 8-9).
4. Position unions on all connections as close to the Drane-kooler as possible to make cleaning and maintenance easier.
5. Cold water supply connection instructions:
 - Cold water supply connection on valve is 3/8" (DN10) pipe thread.
 - Pipe a 3/8" (DN10) line directly to the Drane-kooler from the main water supply line.

To ensure adequate water pressure to the Drane-kooler, do not connect to a supply water line that is dedicated to other appliances.

If installing the Drane-kooler with a humidifier, do not branch off the 1/4" (DN8) cold water supply line to the humidifier.

 - Verify that the supply water pressure to the valve is at least 25 psi (172 kPa) and not more than 80 psi (552 kPa).
 - Install a cold water supply union as close to the Drane-kooler as possible.
 - Install a cold water shut-off valve before the union in the cold water supply line.
6. Hot water inlet connection instructions:
 - Hot water inlet connection is 1" (DN25) pipe thread.
 - Locate a union as close to the Drane-kooler as possible
 - Run 1" (DN25) pipe as directly as possible from the hot water appliance (humidifier) to the Drane-kooler. If the piping to the hot water inlet has a horizontal run, maintain a pitch to the Drane-kooler of at least 1/8"/ft (1%).
7. Tempered water (to drain) connection instructions:
 - Tempered water outlet connection is 2" (DN50) pipe thread.
 - Install a union as close to the Drane-kooler as possible.
 - Run a 2" (DN50) pipe as directly as possible from the Drane-kooler to the drain. Maintain a pitch to drain of at least 1/8"/ft (1%).
 - Make sure there is a 1" (25 mm) air gap between the drain piping and the drain.

Mounting

Three mounting options

Use one of the mounting options shown on this page to ensure that the Drane-kooler will be properly supported and not secured entirely by piping. Floor stand and suspension mount hanger assembly are ordered separately.

**Figure 7-1:
Standard wall mount**

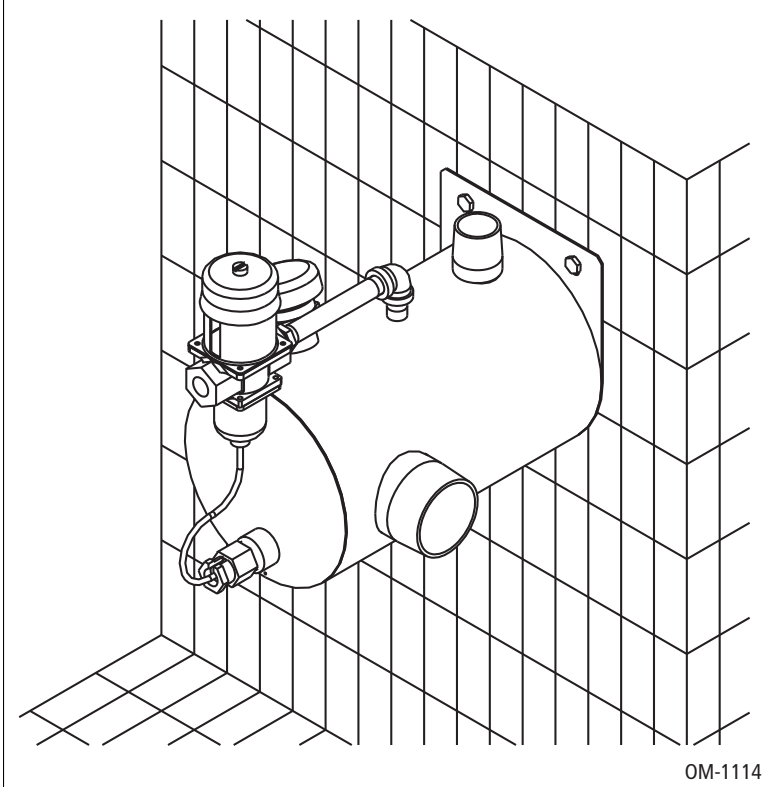

**Figure 7-2:
Optional suspension mount***

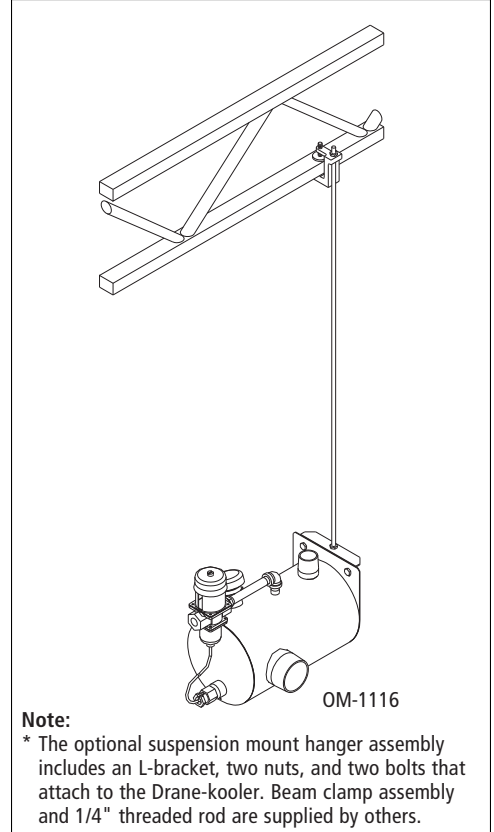

**Figure 7-3:
Optional floor mount**

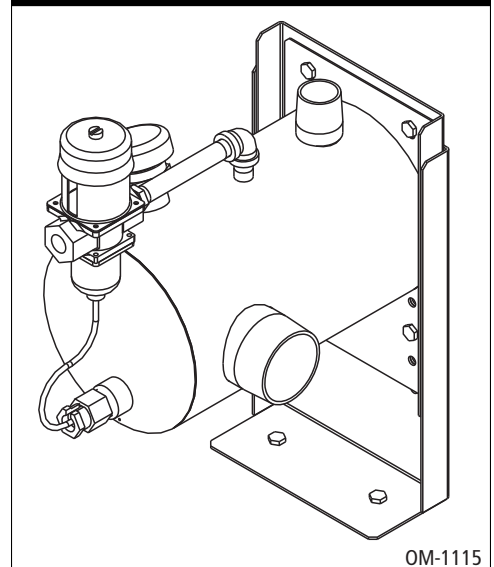

Piping

**Figure 8-1:
Drane-kooler piping**

Cold water supply piping:
3/8" (DN10) pipe thread
Water pressure must be between 25 psi and 80 psi (172 kPa and 552 kPa).
Connect directly to the main water supply line. **To ensure adequate water pressure to the Drane-kooler, do not connect to a supply water line that is dedicated to other appliances.**

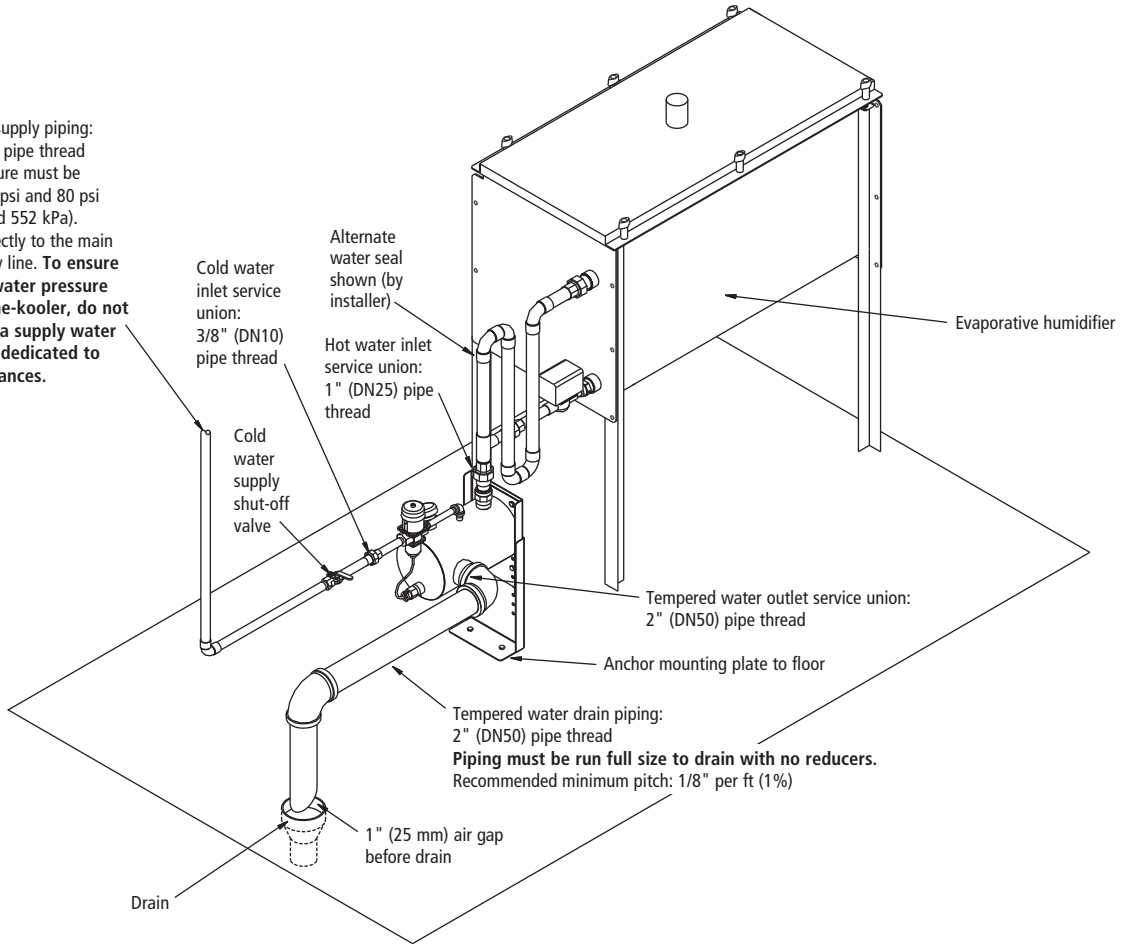

OM-1120

**Figure 8-2:
Drane-kooler mounted directly underneath an evaporative humidifier**

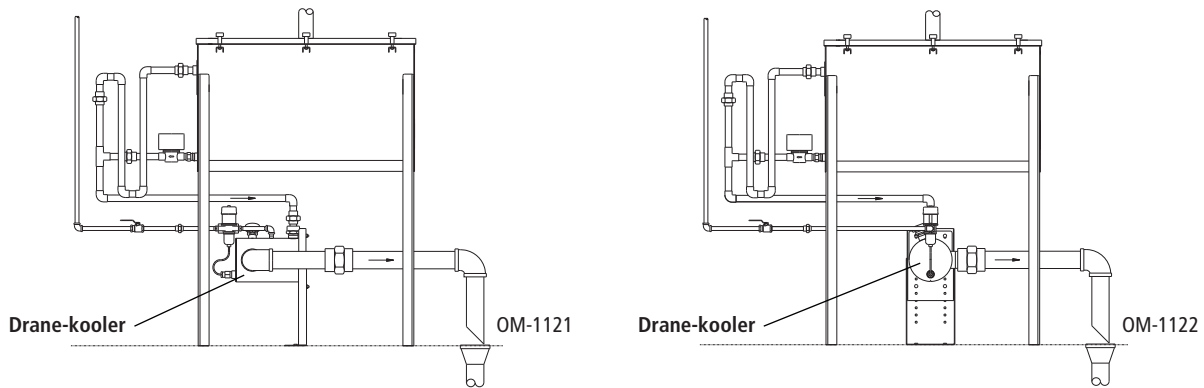

Note:
Pitch drain piping at least 1/8" /ft (1%) in direction arrows.

Start-up and operating instructions

How to operate

Once properly installed, to operate simply open the cold water supply line.

Principle of operation

1. Hot water discharged from a humidifier or other appliance enters the Drane-kooler through piping connected to the top threaded connection. The vacuum breaker prevents backflow into potable water systems.
2. Cold water enters through the temperature-actuated valve. The valve and the Drane-kooler's straightforward design ensure efficient mixing of hot and cold water. The valve's sensor, located near the outlet, ensures that water leaving the Drane-kooler is less than 140 °F (60 °C)* before entering the municipal sewer system.
3. Tempered water at 140 °F (60 °C)* or less exits through the side outlet for safe discharge into a municipal sewer system or PVC pipe.

*Please see the capacities table on Page 4.

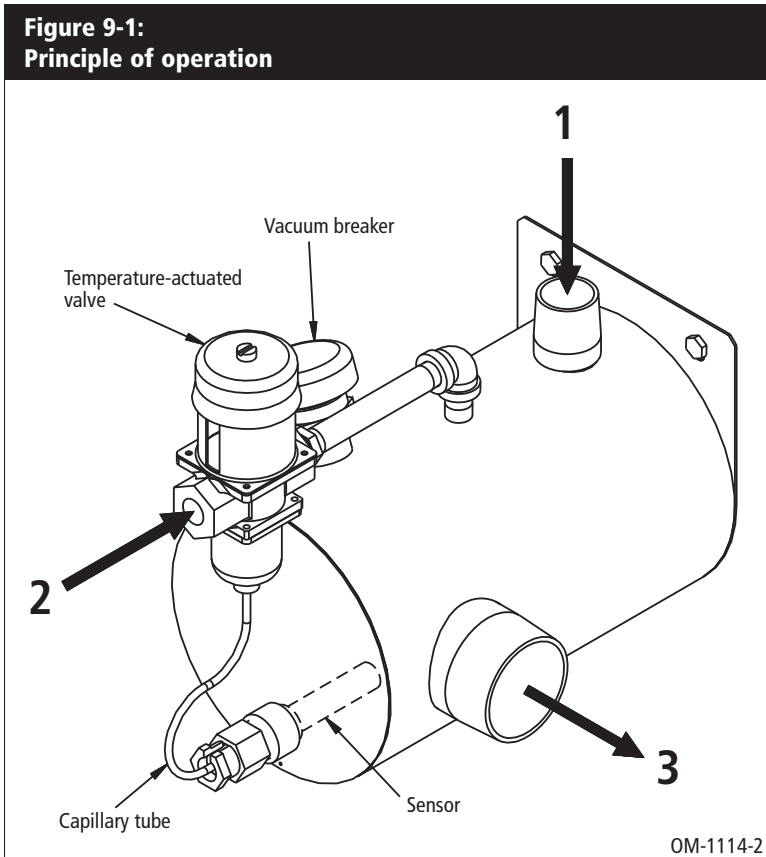

Maintenance and troubleshooting

Step-by-step maintenance instructions

1. Shut off cold water supply.
2. Disconnect service unions at:
 - Cold water supply inlet
 - Hot water inlet
 - Tempered water drain outlet
3. Remove the Drane-kooler from piping and take to a service sink. Add water and, with pipe caps or hands covering the hot water inlet and tempered water outlet, shake the Drane-kooler to dislodge mineral deposits. Dump mineral deposits and rinse.
4. If severe mineral accumulation has occurred, remove the thermal sensor from the Drane-kooler chamber and gently clean the sensor with an abrasive pad. Do not twist the capillary tube during removal or cleaning.
5. Reconnect service unions and open cold water supply valve to resume operation.

**Table 10-1:
Troubleshooting**

Problem	Possible cause	Action
Water leaving the Drane-kooler is hotter than 140 °F (60 °C)	• Mineral accumulation in mixing chamber	• Remove the Drane-kooler and dislodge mineral accumulation.
	• Mineral accumulation on thermal sensor	• Remove thermal sensor from Drane-kooler and gently remove mineral accumulation with an abrasive pad. Do not twist capillary tubing during removal or cleaning.
	• Valve malfunction	• Valve is not working properly. Replace. Note: This valve is factory-set and should not need adjustment.
	• Steam is entering the Drane-kooler	• The Drane-kooler is designed to handle hot water and hot condensate. If a large amount of steam enters the Drane-kooler it is likely that discharge water temperatures will be greater than 140 °F (60 °C). Check P-traps on humidifier or other appliance to ensure that the P-traps have the proper depth and are working properly to prevent steam from entering the Drane-kooler.
Makes a loud popping or crackling noise	• Steam is entering the Drane-kooler	• If steam is entering the Drane-kooler, the introduction of cold water through the valve will cause the steam to collapse and make a popping or crackling sound. Check P-traps on humidifier or other appliance to ensure that the P-traps have the proper depth and are working properly.

Replacement parts

**Figure 11-1:
Replacement parts**

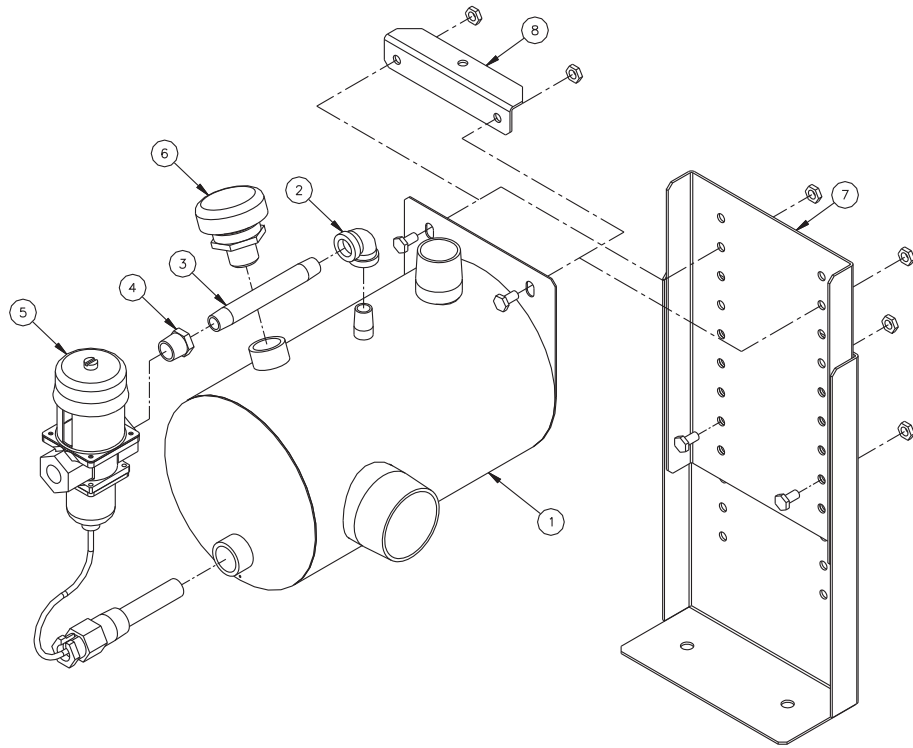

OM-1119

**Table 11-1:
Model DK-12 replacement parts**

Item	Description	Part number
1	Drane-kooler weldment, Model DK-12	167001-020
2	Elbow, 1/4" pipe thread brass	250701-001
3	Nipple, 1/4" pipe thread x 4" brass	250212-004
4	Bushing, 3/8" x 1/4" hex reducer	203550-001
5	Water tempering valve	505090
6	Valve, 1/2" N36 vacuum relief	320400
7	Floor stand assembly	185110
8	Suspension mount hanger assembly	185100

Expect quality from the industry leader

For more than 40 years, DRI-STEEM has been leading the industry with creative and reliable humidification solutions. Our focus on quality is evident in the construction of our products, which feature an industry-leading Two-year Limited Warranty.

For more information

www.dristeem.com
sales@dristeem.com

For the most recent production information, visit our website, www.dristeem.com

DRI-STEEM Corporation

An ISO 9001:2000 certified corporation

U.S. Headquarters:

14949 Technology Drive
Eden Prairie, MN 55344
800-328-4447
952-949-2415
952-229-3200 (fax)

European office:

Marc Briers
Grote Hellekensstraat 54 b
B-3520 Zonhoven
Belgium
+3211823595 (voice)
+3211817948 (fax)
E-mail: marc.briers@dristeem.com

Continuous product improvement is a policy of DRI-STEEM Corporation; therefore, product features and specifications are subject to change without notice.

DRI-STEEM and Dri-calc are registered trademarks of DRI-STEEM Corporation and are filed for trademark registration in Canada and the European community.

Drane-kooler is a trademark of DRI-STEEM corporation.

© 2010 DRI-STEEM Corporation

Two-year Limited Warranty

DRI-STEEM Corporation (“DRI-STEEM”) warrants to the original user that its products will be free from defects in materials and workmanship for a period of two (2) years after installation or twenty-seven (27) months from the date DRI-STEEM ships such product, whichever date is the earlier.

If any DRI-STEEM product is found to be defective in material or workmanship during the applicable warranty period, DRI-STEEM’s entire liability, and the purchaser’s sole and exclusive remedy, shall be the repair or replacement of the defective product, or the refund of the purchase price, at DRI-STEEM’s election. DRI-STEEM shall not be liable for any costs or expenses, whether direct or indirect, associated with the installation, removal or reinstallation of any defective product. The Limited Warranty does not include cylinder replacement for electrode steam humidifiers.

DRI-STEEM’s Limited Warranty shall not be effective or actionable unless there is compliance with all installation and operating instructions furnished by DRI-STEEM, or if the products have been modified or altered without the written consent of DRI-STEEM, or if such products have been subject to accident, misuse, mishandling, tampering, negligence or improper maintenance. Any warranty claim must be submitted to DRI-STEEM in writing within the stated warranty period. Defective parts may be required to be returned to DRI-STEEM.

DRI-STEEM’s Limited Warranty is made in lieu of, and DRI-STEEM disclaims all other warranties, whether express or implied, including but not limited to any IMPLIED WARRANTY OF MERCHANTABILITY, ANY IMPLIED WARRANTY OF FITNESS FOR A PARTICULAR PURPOSE, any implied warranty arising out of a course of dealing or of performance, custom or usage of trade.

DRI-STEEM SHALL NOT, UNDER ANY CIRCUMSTANCES BE LIABLE FOR ANY DIRECT, INDIRECT, INCIDENTAL, SPECIAL OR CONSEQUENTIAL DAMAGES (INCLUDING, BUT NOT LIMITED TO, LOSS OF PROFITS, REVENUE OR BUSINESS) OR DAMAGE OR INJURY TO PERSONS OR PROPERTY IN ANY WAY RELATED TO THE MANUFACTURE OR THE USE OF ITS PRODUCTS. The exclusion applies regardless of whether such damages are sought based on breach of warranty, breach of contract, negligence, strict liability in tort, or any other legal theory, even if DRI-STEEM has notice of the possibility of such damages.

By purchasing DRI-STEEM’s products, the purchaser agrees to the terms and conditions of this Limited Warranty.

Extended warranty

The original user may extend the term of the DRI-STEEM Limited Warranty for a limited number of months past the initial applicable warranty period and term provided in the first paragraph of this Limited Warranty. All the terms and conditions of the Limited Warranty during the initial applicable warranty period and term shall apply during any extended term. An extended warranty term of an additional twelve (12) months or twenty four (24) months of coverage may be purchased. The extended warranty term may be purchased until eighteen (18) months after the product is shipped, after which time no extended warranties are available.

Any extension of the Limited Warranty under this program must be in writing, signed by DRI-STEEM, and paid for in full by the purchaser.

mc_051308_0630