

DRISTEEM[®]
The humidification experts

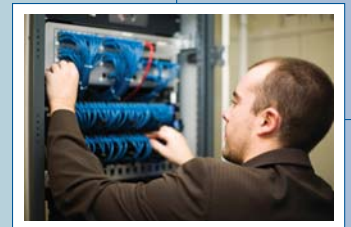

CRUV[®]
Electric-to-Steam
Humidification System
PRODUCT CATALOG



Now with Vapor-logic[®]4 controller option:

- Web-enabled access
- Interoperability via Modbus[®] or optional BACnet[®] MS/TP or LonTalk[®]

Humidifiers for packaged systems

Figure 2-1:
CRUV in a packaged air conditioning unit

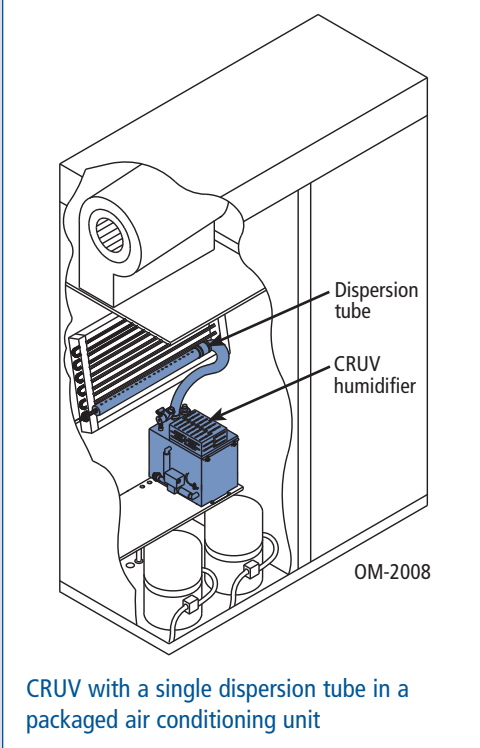

The compact CRUV humidifier can be mounted inside an existing enclosure, such as a packaged air conditioning unit or added to an existing system, such as an environmental chamber. CRUV is self contained, compatible with all water types, and the clear choice for adding a humidification system while meeting minimum space requirements. And CRUV humidifiers provide reliable control to $\pm 3\%$ RH.

The standard LW series electronic control system controls water levels and drain and flush cycles. The Vapor-logic4 microprocessor controller is available for applications requiring advanced control.



Advanced control

The optional Vapor-logic4 controller sets new standards for control in electric steam humidification:

Interoperability allows communication with building automation systems via Modbus or with optional BACnet MS/TP or LonTalk protocols.

Safety presets initiate fill and drain cycles and keep the humidifier cool and safe if sensed conditions, though unlikely, could be hazardous.

Web-enabled control allows you to set up, view, and adjust humidifier functions via Ethernet, either directly or remotely through a network.

DRISTEEM Vapor-logic4

STATUS ALARMS DIAGNOSTICS SETUP HELP

System Status

DEMAND	OUTPUT
0%	0%

RUN MODE: Local standby

TANK STATUS: Empty

Alarms
2 active alarms
[View Alarms](#)

Messages
2 active messages
[View Messages](#)

Wednesday, January 27, 2010 3:42:28 PM Data stream is LIVE

View all humidifier settings below. Some settings can be changed here. Go to the Setup tab to change settings that cannot be changed from this page.

TANK STATUS:

Run Mode	Local standby	<input type="button" value="CHARGE"/>
Input signal	18.2 VDC	
Steam output	0%	
Steam production	0 lbs/hr	
Duct HI, switch	Closed	
Tank temperature	192°F	
Tank temp signal	1623 Ohms	
High water probe	Water	
Mid water probe	Water	
Low water probe	Water	
Fill valve	Open	
Drain valve	Open	
Airflow switch	Flow	
Interlock switch	Closed	
H2O until drain/flush	123456 lbs	
H2O until service	30000 lbs	
High probe signal	3874	
Mid probe signal	3875	
Low probe signal	3873	

© Copyright 2009 DRI-STEEM Corporation. All rights reserved. Vapor-logic is a registered trademark of DRI-STEEM Corporation.

CRUV features and benefits

Versatile

- Supports all water types: tap, softened, reverse osmosis, and deionized
- Capacity from 6 to 102 lbs/hr (2.7 to 46 kg/h)
- Standard LW series controller and optional Vapor-logic4 controller for multiple levels of control capability

Flexible

- Dispersion with steam dispersion panels or tubes for broad application flexibility
- On-off or time-proportioned (TP) control for application control in most environments; solid-state relay (SSR) option for tight control
- Electronically monitored water level ensures consistent, reliable operation at any capacity

Easy to maintain

- Heating elements and power conductors attach to tank cover for easy tank access without disconnecting wires or plumbing
- Softened water significantly reduces maintenance requirements
- End-of-season autodrain minimizes microbial growth
- User-adjustable water skimmer removes surface residue
- Controller-operated drain and flush removes precipitated minerals from evaporating chamber
- Constant thermal expansion and contraction of heating elements continuously sheds mineral buildup

Figure 3-1:
Clean room application



Two control options

Vapor-logic4 keypad/display

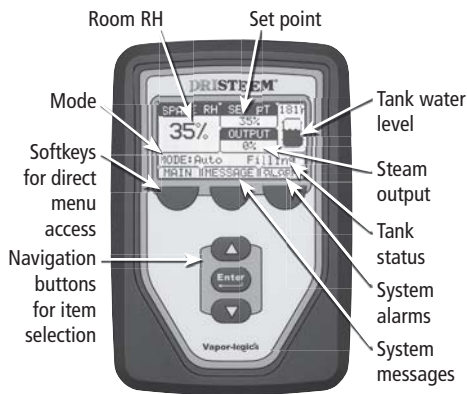

Web interface

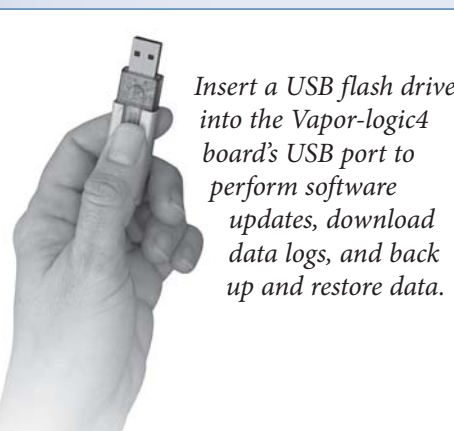

LW series control

An electronic module in the LW series control system, standard on CRUV, controls water levels and drain/flush cycles. Dip switches on the control board can be field-set to select timer-operated drain/flush cycles and water skimming durations. LEDs on the control board provide Power, Full, Drain, and Ready statuses.

Advanced Vapor-logic4 control

The Vapor-logic4 controller option provides accurate, responsive RH control. PID control tunes the system for maximum performance.

Modbus, BACnet MS/TP, or LonTalk allow interoperability with multiple building automation systems. Modbus is standard, and BACnet MS/TP or LonTalk are available options.

Web interface provides the capability to set up, view, and adjust humidifier functions via Ethernet, either directly or remotely through a network.

Cycle counter triggers a message when it's time to replace the contactor.

USB port allows easy firmware updates, and data backup and restore capability.

Real-time clock allows time-stamped alarm and message tracking, and accurate drain and flush scheduling.

Programmable outputs allow remote signaling and device activation.

Controller data, such as RH, air temperature, water use, energy use, alarms, and messages, can be downloaded to a PC for viewing and analysis. RH, alarms, and messages can also be viewed on the keypad/display and Web interface.

Enhanced diagnostics include:

- **Test outputs** function using keypad/display or Web interface to verify component operation
- **Test humidifier** function using simulated demand to validate performance

mc_042710_1500-CRUV

Principle of operation

1. When the system is first activated, the fill valve opens and the evaporating chamber fills with water to the operating level.
2. On a call for humidity, the heating elements are energized, causing the water to boil. The fill valve opens and closes as needed to maintain the operating water level.
3. During refill, a portion of the surface water is skimmed off, carrying away precipitated minerals.
4. Steam created in the evaporating chamber flows through vapor hose or piping to the dispersion assembly, where it is discharged into the airstream.

Figure 5-1:
CRUV principle of operation

Tap/softened water CRUV shown

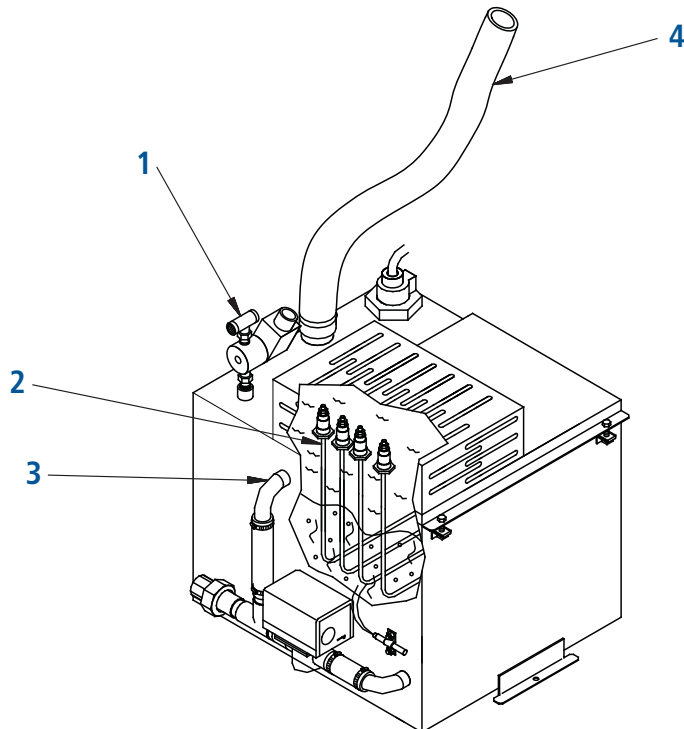

mc_071210_1600

OM-2001-1

CRUV components

Figure 6-1:
Water level control for tap/softened water humidifier

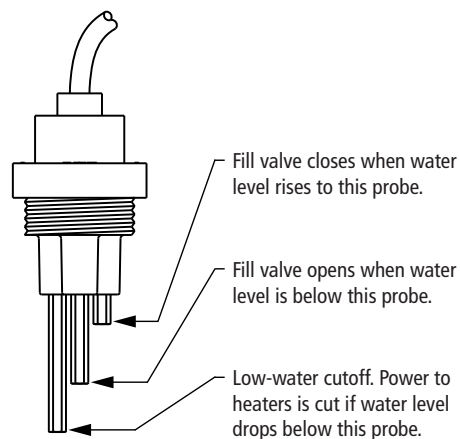

Humidifiers using tap or softened water control water levels electronically using a three-rod probe. The controller responds with the above actions when the water level reaches each rod.

mc_030910_1335

VLC-OM-030

1. Controller (not shown)

The LW series control system controls water levels, timer-operated drain/flush cycles, and water skimming durations. The optional Vapor-logic4 microprocessor control system controls all humidifier functions. See Page 4.

2. Water level control

Tap/softened water humidifiers control water levels electronically using a three-rod probe (Figure 6-1). DI/RO water humidifiers control water levels using a float valve and low-water cutoff switch (Figure 6-2).

3. Service access

Heating elements and power conductors attach to the removable tank cover for easy tank access without disconnecting wires or plumbing.

4. Heating elements

Low-watt-density Incoloy-sheathed heating elements ensure operation for many seasons. Constant expansion and contraction of heating elements sheds mineral scale. In the unlikely event of heater failure, heating elements remove easily for replacement.

5. Tank temperature sensor

The tank temperature sensor mounts on the tank to enable over-temperature protection, freeze protection, and tank preheating. Preheating allows a rapid response to a call for humidity.

Figure 6-2:
Water level control for DI/RO water option humidifier

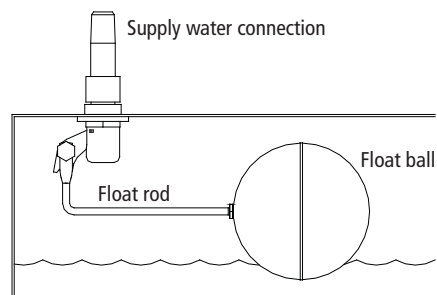

Humidifiers using DI/RO water control water levels using a float valve and low-water cutoff switch.

mc_052710_1644

OM-7396

CRUV Components

6. Drain

With the LW series controller, drain duration and frequency are user-adjustable via dip switches on the control board. With the Vapor-logic4 controller, drain duration and frequency are user-adjustable via the keypad/display or web interface.

To avoid possible stagnant water and microbial growth, humidifiers with the end-of-season drain option automatically drain if there is no call for humidity after a defined time period.

7. Water skimmer

The water skimmer reduces surface residue in the evaporating chamber. Skimming occurs each time the humidifier fills. Skim duration is user adjustable.

8. Steam outlet

Generated steam rises and exits through the steam outlet and travels to the dispersion unit through vapor hose or piping.

Figure 7-1:
CRUV components

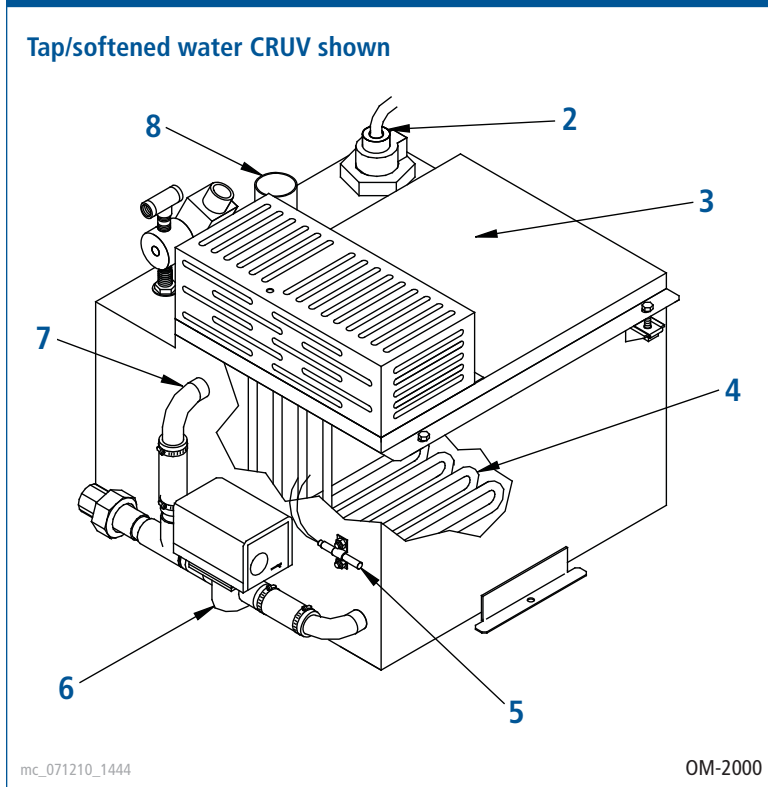

CRUV specifications

**Table 8-1:
Vapormist capacities, electrical specifications, and weights**

CRUV model	Maximum steam capacity**		Current draw (amps)											Shipping weight***		Operating weight***	
			Single-phase						Three-phase								
kW	lbs/hr	kg/h	120V	208V	240V	277V	480V	600V	208V	240V	277V	480V	600V	lbs	kg	lbs	kg
2	6	2.7	16.7	9.6	8.3	7.2	4.2	3.3	—	—	—	—	—	25	11	45	20
4	12	5.4	33.3	19.2	16.7	14.4	8.3	6.7	16.7*	14.4*	12.5	7.2*	5.8*	27	12	47	21
6	18	8.2	—	28.8	25.0	21.7	12.5	10.0	25.0*	21.7*	18.8	10.8*	8.7*	37	17	75	34
8	24	10.9	—	38.5	33.3	28.9	16.7	13.3	33.3*	28.9*	25.0	14.4*	11.5*	37	17	75	34
10	30	13.6	—	—	41.7	36.1*	20.8	16.7	29.1*	25.3*	21.9	12.6*	10.1*	39	18	90	41
12	36	16.3	—	—	—	43.3	25.0	20.0	33.3	28.9	25.0	14.4	11.5	39	18	90	41
14	42	19.1	—	—	—	—	29.2	23.3	38.9	33.7	29.2	16.8	13.5	39	18	90	41
16	48	21.8	—	—	—	—	33.3	26.7	44.4	38.5	33.3	19.2	15.4	39	18	90	41
21	63	28.6	—	—	—	—	43.8	35.0	—	—	43.8	25.3	20.2	43	20	104	47
25	75	34.0	—	—	—	—	—	41.7	—	—	—	30.1	24.1	43	20	104	47
30	90	40.9	—	—	—	—	—	—	—	—	—	36.1	28.9	48	22	109	49
34	102	46.3	—	—	—	—	—	—	—	—	—	40.9	32.7	48	22	109	49

* For wire sizing, the highest leg draw is shown due to current imbalance.

** Total humidifier load = load to meet design conditions + load to compensate for steam loss from the dispersion assembly and interconnecting piping. If total humidifier load is more than the humidifier's maximum capacity, design conditions will not be met. For steam loss data see the DRI-STEEM Design Guide available for downloading and printing at www.drasteem.com

*** Depending on configuration, add up to 28 lbs (13 kg) for weight of control cabinet, subpanel, and other electrical control components.

mc_071210_1440

CRUV dimensions

**Figure 9-1:
CRUV dimensions**

CRUV for DI/RO water shown

Electrical conduit knockouts:

- CRUV Models 2 and 4 have combination knockout for 1/2" and 3/4" conduit connectors; knockout diameters are 22.3 mm and 28.6 mm.
- CRUV Models 6 through 34 have combination knockout for 3/4" and 1" conduit connectors; knockout diameters 28.6 mm and 34.9 mm.

Side view

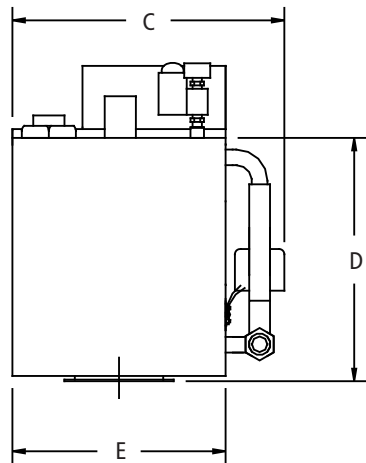

Top view

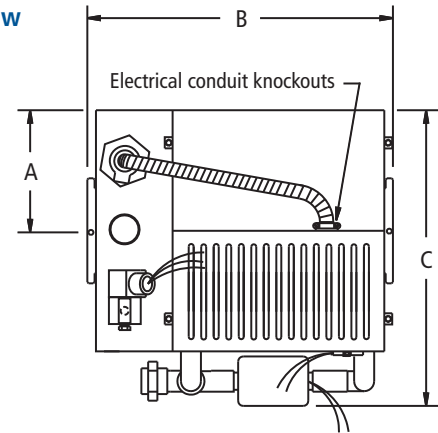

Front view

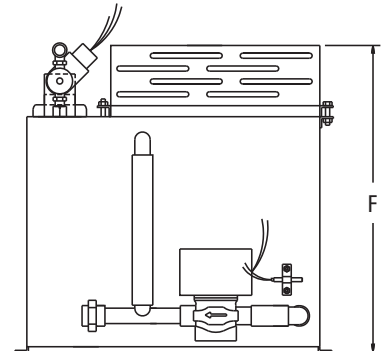

mc_071210_1445

OM-2004, OM-2002, OM-2003

**Table 9-1:
CRUV dimensions**

CRUV model	A		B		C		D		E		F	
	inches	mm	inches	mm	inches	mm	inches	mm	inches	mm	inches	mm
2, 4	4.50	114	15.50	394	12.50	318	9.00	229	9.00	229	12.13	308
6, 8	7.18	183	16.00	406	16.88	429	10.00	254	14.34	369	13.25	337
10, 12, 14, 16	7.18	183	16.00	406	16.88	429	11.75	199	14.34	364	14.88	378
21, 25, 30, 34	7.18	183	16.00	406	16.88	429	13.25	337	14.34	364	16.38	416

mc_071210_1446

CRUV piping: Tap/softened water

Figure 10-1:
CRUV (tap/softened water) field piping overview

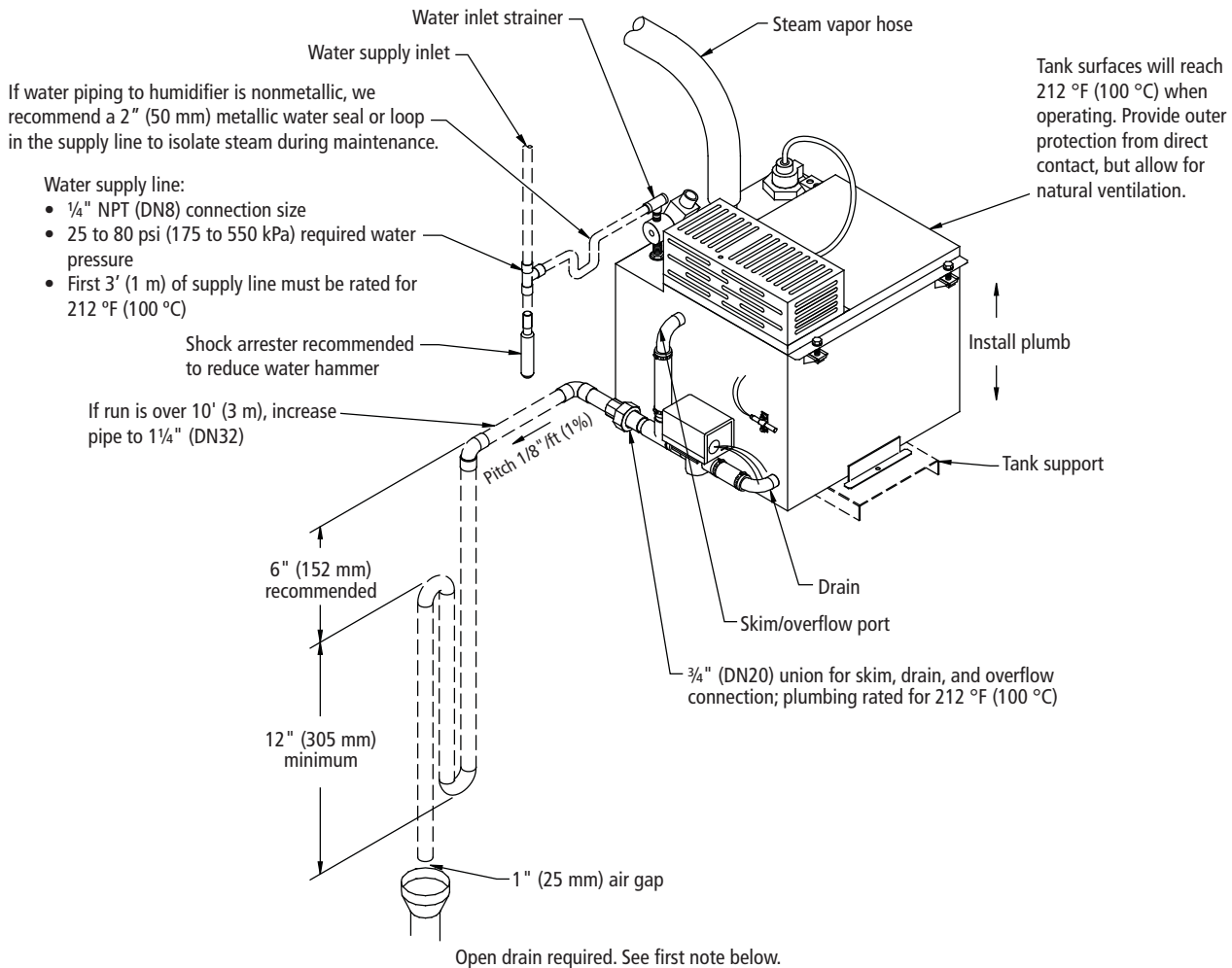

Notes:

- Locate air gap only in spaces with adequate temperature and air movement to absorb flash steam; otherwise, condensation may form on nearby surfaces. Refer to governing codes for drain pipe size and maximum discharge water temperature.
- Offset humidifier from floor drain to prevent flash steam from rising into the humidifier.
- Dashed lines indicate provided by installer.
- The water supply inlet is more than 1" (25 mm) above the skim/overflow port, eliminating the possibility of backflow or siphoning from the tank. No additional backflow prevention is required; however, governing codes prevail.
- Damage caused by chloride corrosion is not covered by your DRI-STEEM warranty.

mc_071210_1603

DC-1133

CRUV piping: DI/RO water option

**Figure 11-1:
CRUV (DI/RO water option) field piping overview**

If water piping to humidifier is nonmetallic, we recommend a 2" (50 mm) stainless steel water seal or loop in the supply line to isolate steam during maintenance

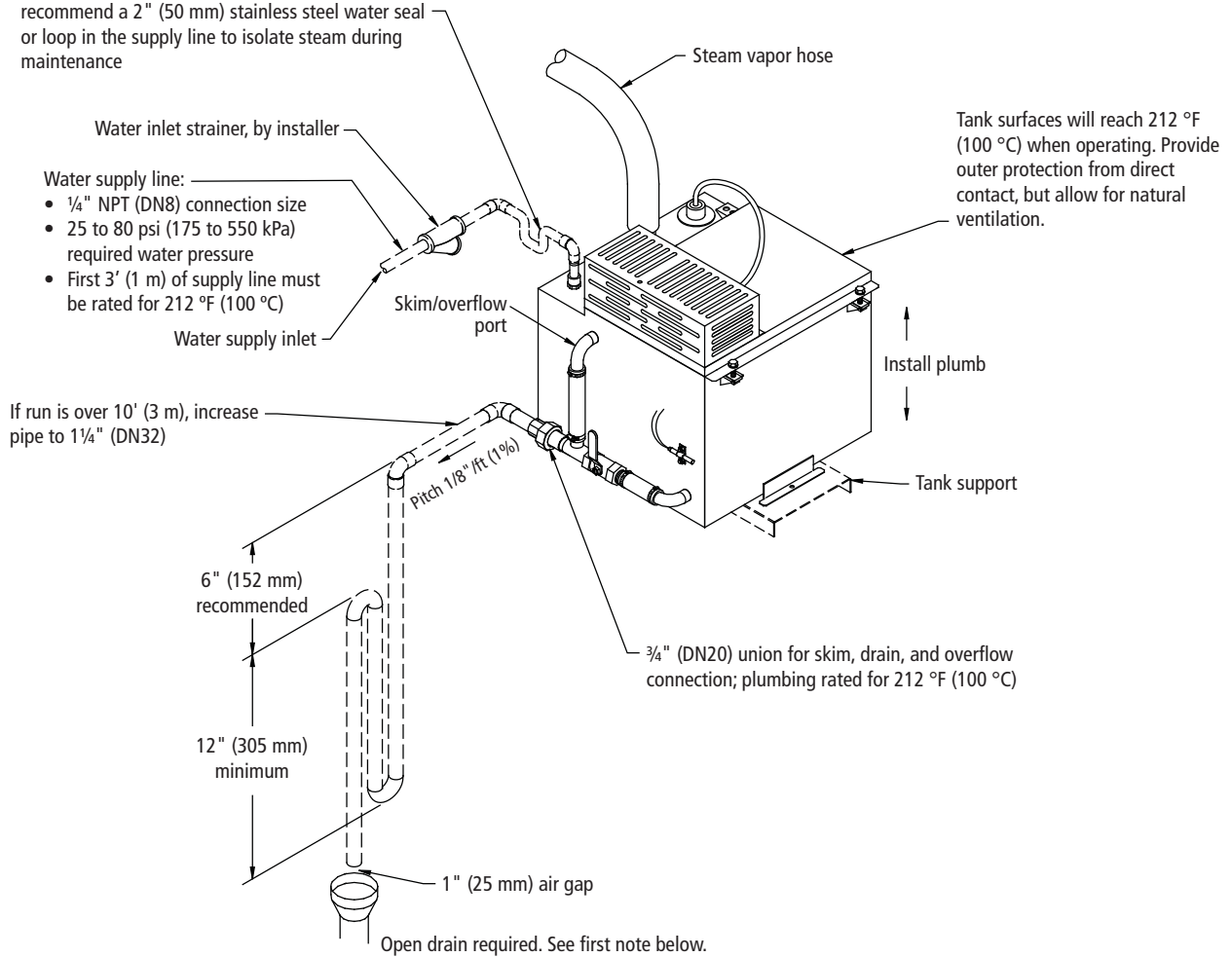

Notes:

- Locate air gap only in spaces with adequate temperature and air movement to absorb flash steam; otherwise, condensation may form on nearby surfaces. Refer to governing codes for drain pipe size and maximum discharge water temperature.
- Offset humidifier from floor drain to prevent flash steam from rising into the humidifier.
- Dashed lines indicate provided by installer.
- The water supply inlet is more than 1" (25 mm) above the skim/overflow port, eliminating the possibility of backflow or siphoning from the tank. No additional backflow prevention is required; however, governing codes prevail.
- Damage caused by chloride corrosion is not covered by your DRI-STEEM warranty.

mc_071210_1604

DC-1135

Drip-free dispersion basics

Guaranteed absorption

- Cataloged and guaranteed steam absorption distances
- Unique tubelets in dispersion tubes eliminate condensate drips
- Published absorption tables for sizing and selecting the correct dispersion option
- Dri-calc® software available for system selection and absorption distance calculations

Figure 12-1:
DRI-STEEM dispersion tubes



DRI-STEEM's dispersion tubes are fitted with one or two rows of closely-spaced thermal-resin tubelets to evenly disperse steam across the airstream.

mc_042610_1555

Figure 12-2:
DRI-STEEM tubelets

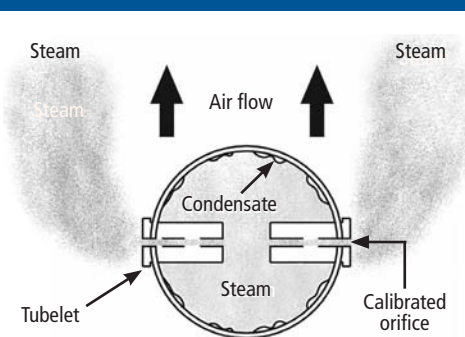

DRI-STEEM's unique tubelets extend into the center of the tube so only the driest steam is discharged into the air.

mc_042610_1550

OM-150a

Guaranteed non-wetting distances

Using data collected in our on-site test lab, we have developed guaranteed steam absorption (non-wetting) distances. Performance charts allow you to confidently choose equipment that will accommodate any application.

Dry steam

Adding humidification to an airstream without creating wetness in the duct system is critical for the maintenance of a healthy environment. Wet areas in ducts are a threat to the health of building occupants since they moisten dust on duct floors, creating ideal breeding grounds for disease-producing microbes. In addition, water accumulating in ducts can drip and cause building damage.

Steam exits drip-free through tubelets

All DRI-STEEM evaporative dispersion tube units discharge steam through thermal-resin tubelets fitted into dispersion tubes. These tubelets extend from the center of the tube, where the steam is driest, through the tube wall, to the duct airstream. In essence, the tubelets provide a temperature-neutral exit tunnel for steam, allowing steam to cross over lower-temperature metal without condensing or dripping. Each tubelet contains a calibrated orifice sized for steam capacity. These tubelets are a DRI-STEEM exclusive, and are essential for drip-free steam dispersion.

Condensate drains away

Some condensation is inevitable in steam dispersion, but through careful design, condensate can be controlled and directed away from where it can cause problems.

For example, the Ultra-sorb dispersion panel has a unique double-header design that uses gravity to remove condensate. Steam enters the supply header, exits through the tubelets, and condensate drains out the return header. In the Rapid-sorb dispersion unit, steam enters one end of a single bottom header with velocities carefully managed so that condensate is not pushed out into the air along with the steam; it drains out at the opposite end of the header.

Reduce condensate, wasted energy with high-efficiency tubes

To significantly reduce condensate and wasted energy, use DRI-STEEM's high-efficiency tubes, which reduce dispersion-generated condensate and wasted energy by up to 85%. See "High-efficiency Tube option" on Page 12.

mc_042610_1630

CRUV steam dispersion options

Ultra-sorb®

- Double-header design
- Shortest non-wetting distance; install within inches of upstream dampers, coils, or elbows without dripping
- Steam capacity up to 1,850 lbs/hr (839 kg/h)
- Factory assembled for easy installation
- High-efficiency tube option



Rapid-sorb®

- Single-header design
- Short non-wetting distance
- Steam capacity up to 800 lbs/hr (363 kg/h)
- Assembled on-site
- High-efficiency tube option

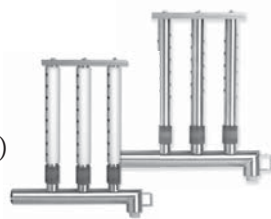

Single or multiple tubes

- Horizontal or vertical airflow
- Available with or without condensate drain
- Steam capacity up to 85 lbs/hr (39 kg/h)



High-efficiency Tube option

- Up to 85% reduction in wasted energy, airstream heat gain, and condensate production
- PVDF insulation is plenum-approved for in-duct installation
- Will not absorb water or support microbial growth; has a closed-cell structure
- Available on Ultra-sorb and Rapid-sorb



Ultra-sorb panel with high-efficiency tubes

mc_042710_1345-NA

Figure 13-1:
Ultra-sorb dispersion

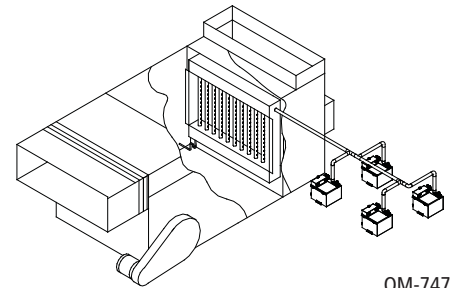

OM-7475

Figure 13-2:
Rapid-sorb dispersion

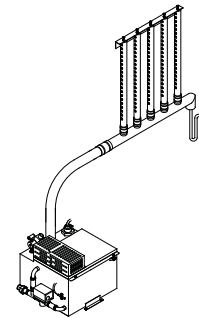

OM-2007

Figure 13-3:
Single or multiple tube dispersion

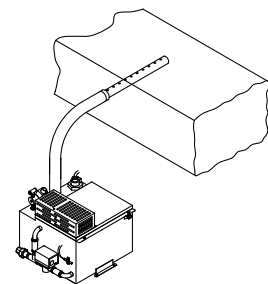

OM-2006

Calculating absorption distances

Notes:

- Final equipment selection should account for condensate loss. See the *DRI-STEEM Design Guide* for steam loss tables.
- Dispersion assembly should accommodate maximum output capacity of humidifier.

Sample exercise

Read through this exercise to learn more about specifying a dispersion unit based on non-wetting distance. Assume you have chosen to use Ultra-sorb units because you want pre-assembled panels.

Assume the entering air is 20% RH, and the leaving air needs to be 70% RH. Design for a non-wetting distance of 24" (610 mm) maximum.

Solution

Refer to Figure 15-1. Find 20% entering RH. Proceed vertically until you intersect the 70% leaving RH line. Draw a line horizontally from that point to the right to see that for 24" (610 mm) of non-wetting distance, 6" (150 mm) tube spacing would be the closest match.

Verify capacity

From Table 15-1, note that for 6" (150 mm) spacing, maximum capacity is 18 lbs/hr/ft² (88 kg/h/m²). Multiply this value by the active face area of the Ultra-sorb to determine if the unit will produce adequate output capacity. If the capacity is inadequate, go to the next smaller tube spacing.

Steam absorption considerations

1. Non-wetting distance is the dimension downstream from the leaving side of the steam dispersion assembly to the point where wetting will not occur, although wisps of steam may be present. Solid objects at duct air temperature, such as coils, dampers, fans, etc., downstream of this dimension will remain dry.
2. **CAUTION!** Non-wetting distances described in this catalog do not apply when installing a steam dispersion assembly upstream of filter media. If you need to install a steam dispersion assembly upstream of filter media, consult your representative or DRI-STEEM directly for special recommendations.
3. Note that the rise (Δ) in RH (the difference between entering and leaving RH) has a direct bearing on the non-wetting distance. As the rise increases, more vapor needs to be dispersed into the air, and thus the non-wetting distance increases.
4. Uneven airflow over the cross-section of a dispersion assembly can result in nonuniform mixing of steam with air which, in turn, will adversely affect the non-wetting distance.

mc_042710_0850

Ultra-sorb dispersion

**Figure 15-1:
Ultra-sorb non-wetting distances**

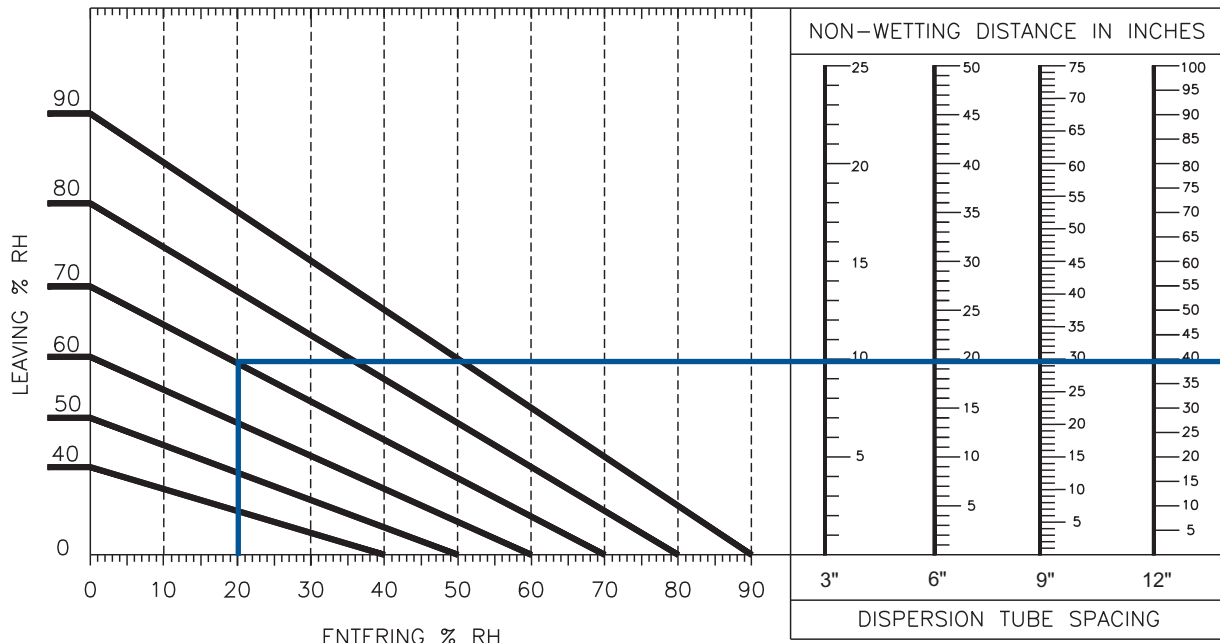

Note:

The above data apply to all air velocities up to 1,500 fpm (7.6 m/s), and are based on air leaving the zone of humidification at conditions of 55 °F (13 °C) and the stated % RH. The blue lines in the graph refer to the sample exercise described on Page 14.

mc_042710_0900

**Table 15-1:
Ultra-sorb tube spacing and capacity**

Tube spacing		Maximum capacity	
inches	mm	lbs/hr/ft ²	kg/h/m ²
3	75	36	175
6	150	18	88
9	225	12	59
12	300	9	44

Note:

The above steam flow capacity data are based on pounds (kg) of steam per hour per square foot (meter) of face area, exclusive of headers, at various tube spacings.

mc_042710_0905

Dispersion: Ultra-sorb

Ultra-sorb LV

- Vertical dispersion tubes
- Suitable for AHUs or ductwork
- Use when duct height is greater than duct width
- May use with pressurized or evaporative steam (horizontal airflow only)

For Ultra-sorb LH (horizontal tubes), see the *Ultra-sorb Steam Dispersion Panels Product Catalog* (available at www.dristeem.com).

Table 16-1:
Evaporative steam header capacities

Header capacity		Header diameter	
lbs/hr	kg/h	inches	DN
300	135	3	80
600	270	4	100
1100	500	5	125
1850	820	6	150

Figure 16-1:
Ultra-sorb LV dimensions

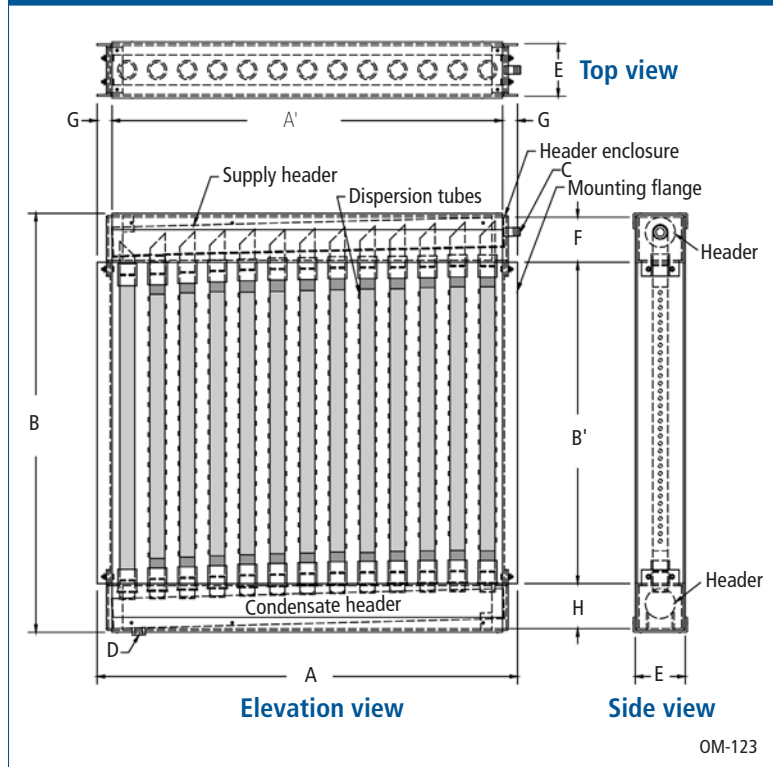

Table 16-2:
Ultra-sorb LV dimensions

Dimension	Inches (mm)
A Overall width	15" (380) min, 147" (3735) max, in 1" (25) increments
A' Face width	12" (305) min, 144" (3660) max, in 1" (25) increments
B Overall height	21" (530) min, 156" (3960) max, in 1" (25) increments Panels with overall height more than 98" (2490 mm) are shipped unassembled.
B' Face height	12" (305) min, 144" (3660) max, in 1" (25) increments
C Steam inlet diameter	Determined by maximum steam capacity
D Condensate drain	¾" pipe thread (DN20)
E Header enclosure (front to back)	For 3" (DN80) and 4" (DN100) headers, E = 5" (127); for 5" (DN125) header, E = 6" (152); for 6" (DN150) header, E = 7" (178)
F Header enclosure (top to bottom)	For 3" (DN80) header F = 4.5" (114); for 4" (DN100) header, F = 5.5" (140); for 5" (DN125) header, F = 6.5" (165); for 6" (DN150) header F = 7.5" (191)
G Flange	1.5" (38)
H Condensate header enclosure	4.5" (114)

Note: Header dimensions are determined by capacity. See Table 16-1.

Dispersion: Rapid-sorb

Figure 17-1:
Rapid-sorb non-wetting distances

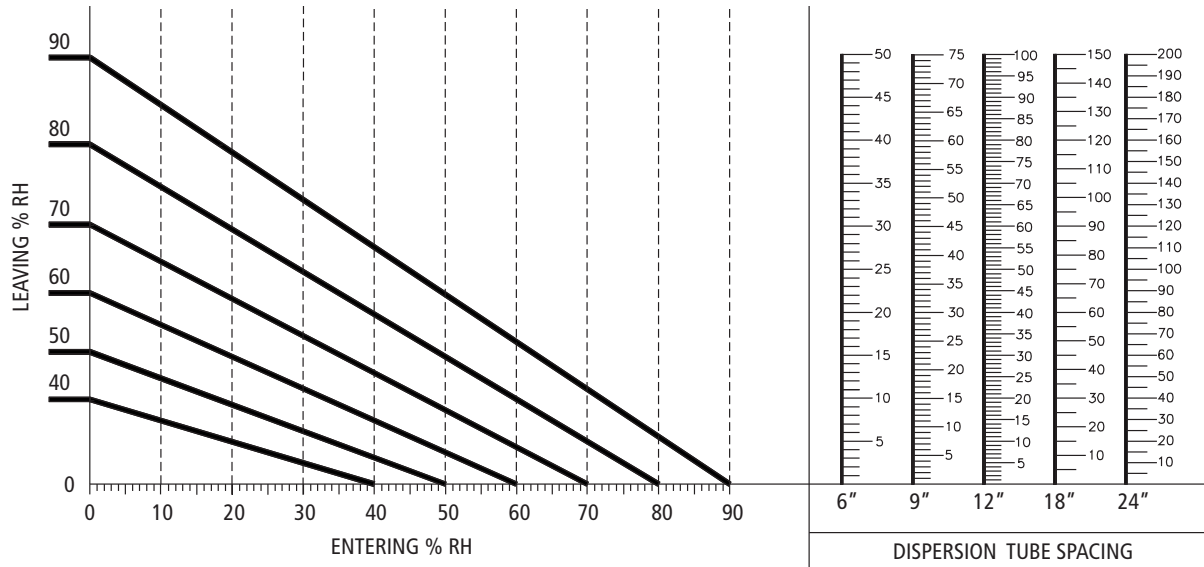

Note:
The above data apply to all air velocities up to 1,500 fpm (7.6 m/s) and are based on air leaving the zone of humidification at 55 °F (13 °C) and the stated % RH.

Table 17-1:
Rapid-sorb dispersion tube capacities*

Tube capacity		Tube diameter	
lbs/hr	kg/h	inches	DN
≤35	≤16	1½	40
36-70	17-32	2	50

* If duct height is <15" (381 mm), tube quantities may need to increase to compensate for reduced capacity of short tubes. Consult DRI-STEEM or see Dri-calc for the correct calculation.

mc_042710_1410

Table 17-2:
Rapid-sorb header capacities

Header capacity		Header diameter	
lbs/hr	kg/h	inches	DN
≤250	≤113	2	50
251-500	114-227	3	80
501-800	228-363	4	100

Dispersion: Rapid-sorb

**Figure 18-1:
Rapid-sorb dimensions**

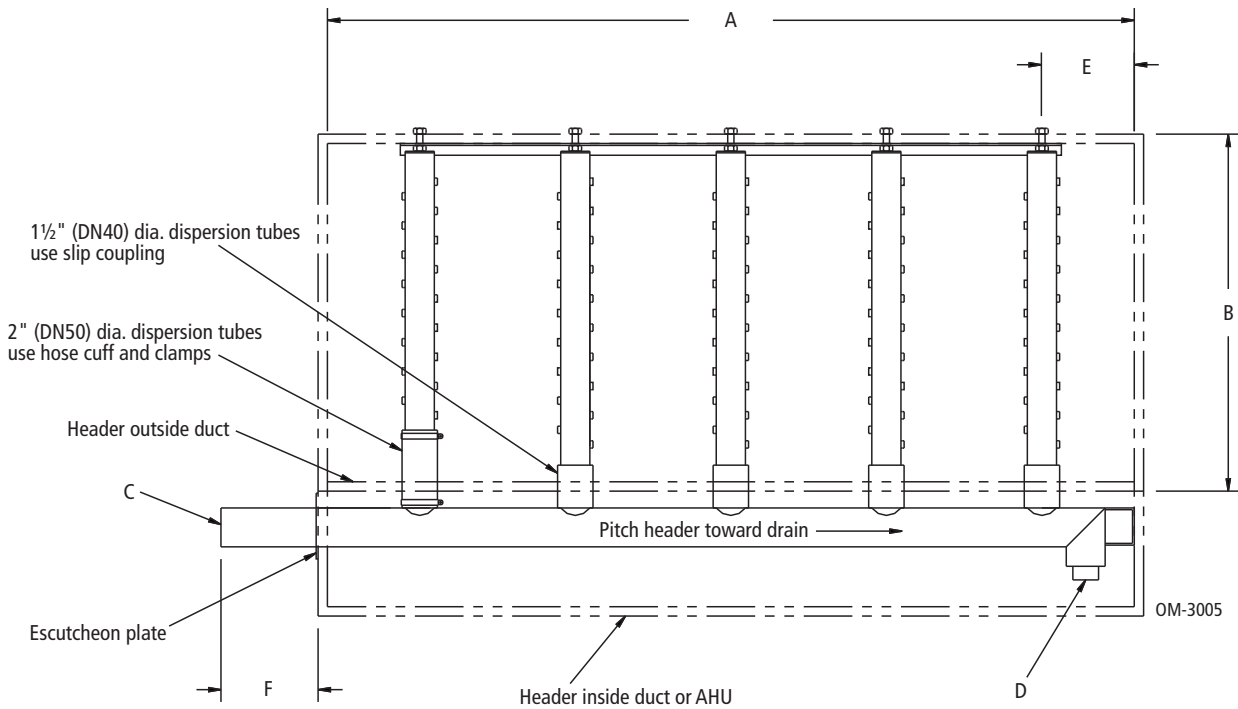

Note:

Add water seal to condensate drain as shown in the Dri-calc Installation Guides or the humidifier's Installation, Operation and Maintenance manual.

**Table 18-1:
Rapid-sorb dimensions**

Dimension	Description	Inches (mm)
A	Face width	12" (305) minimum to 120" (3048) maximum in 1" (25) increments
B	Face height	12" (305) minimum to 120" (3048) maximum in 1" (25) increments
C	Steam inlet	Determined by supply steam pressure
D	Condensate drain	3/4" pipe thread (DN20)
E	Distance from tube center to inside of duct or AHU wall	4.5" (114) minimum
F	Distance from outside of duct or AHU wall to end of Rapid-sorb leader	4.5" (114) minimum

Note:

All Rapid-sorb units are custom-sized and field-assembled to fit the duct or air handler. Consult DRI-STEEM for sizes larger or smaller than those listed above.

mc_042710_1415

Dispersion: Single tube

**Figure 19-1:
Single tube non-wetting distances**

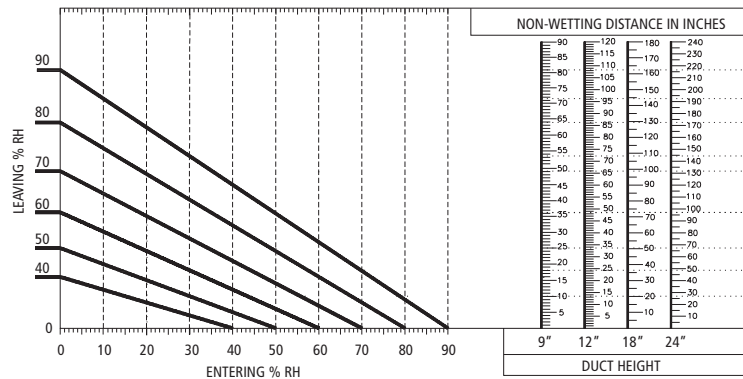

Note:
The above data apply to all air velocities up to 1,500 fpm (7.6 m/s), and are based on air leaving the zone of humidification at conditions of 55 °F (13 °C) and the stated % RH.

mc_042710_1417

**Table 19-1:
Single tube capacities**

Tube size		Maximum capacity of dispersion tube			
		Without drain		With drain	
Inches	DN	lbs/hr	kg/h	lbs/hr	kg/h
1½	40	28.4	13	56.8	25.8
2	50	56.8	25.8	85.2	38.6

mc_042710_1416

**Figure 19-2:
Single tube with and without condensate drain**

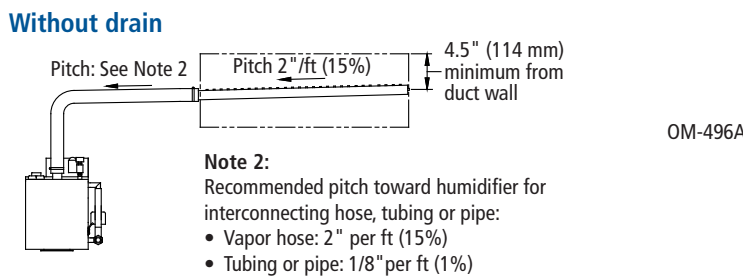
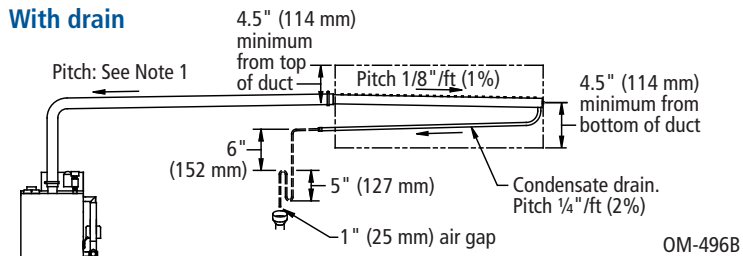

mc_071210_1650-CRUV

**Table 19-2:
Hose kit sizing by model**

CRUV model	Hose kit (vapor hose, dispersion tube, and hardware)
2 through 8	1½" (DN40) hose kit without drain
10 through 16	1½" (DN40) hose kit with drain
	2" (DN50) hose kit without drain
21 through 25	2" (DN50) hose kit with drain
30 through 34	These models require multiple tube assemblies and cannot use a hose kit.

mc_071210_1640-CRUV

Conserving resources through better performance

Expect quality from the industry leader

For more than 45 years, DRI-STEEM has been leading the industry with creative and reliable humidification solutions. Our focus on quality is evident in the construction of the CRUV, which features cleanable, stainless steel construction. DRI-STEEM also leads the industry with a Two-year Limited Warranty and optional extended warranty.

For more information

www.dristeem.com
sales@dristeem.com

For the most recent production information visit our web site:
www.dristeem.com

DRI-STEEM Corporation

An ISO 9001:2000 certified company

U.S. Headquarters:
14949 Technology Drive
Eden Prairie, MN 55344
800-328-4447 or 952-949-2415
952-229-3200 (fax)

European office:
Marc Briers
Grote Hellekensstraat 54 b
B-3520 Zonhoven
Belgium
+3211823595 (voice)
+3211817948 (fax)
E-mail: marc.briers@dristeem.com

Continuous product improvement is a policy of DRI-STEEM Corporation; therefore, product features and specifications are subject to change without notice.

DRI-STEEM, CRUV, Dri-calc, Rapid-sorb, Ultra-sorb, and Vapor-logic are registered trademarks of DRI-STEEM Corporation and are filed for trademark registration in Canada and the European community.

Area-type and Drane-kooler are trademarks of DRI-STEEM Corporation.

Product and corporate names used in this document may be trademarks or registered trademarks. They are used for explanation only without intent to infringe.

© 2010 DRI-STEEM Corporation



Form No. CRUV-CAT-0710 Rev Web



DRI-STEEM conserves resources by designing humidification systems that optimize performance. Systems that perform well save energy and water and, ultimately, cost less to operate and maintain.

Save energy

For applications requiring short absorption, high-efficiency dispersion tubes reduce wasted energy up to 85% by significantly reducing airstream heat gain and condensate production. Available for new and retrofit Ultra-sorb® and Rapid-sorb® steam dispersion panels.



For warm, dry applications, DRI-STEEM's High-Pressure Atomizing System disperses unheated micro-fine water particles into airstreams or open spaces. As atomized water droplets evaporate, air temperature drops, reducing the cooling load. This provides significant energy savings when humidifying and cooling simultaneously.



Save water

Ultra-sorb Model XV eliminates water waste and reduces airstream heat gain, energy costs, and boiler chemical use. Available for all pressurized steam applications.

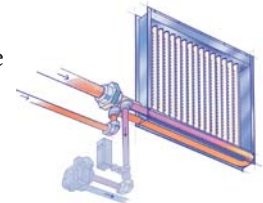

Optimize performance

DRI-STEEM's most advanced controller, Vapor-logic®4 continuously monitors space conditions to align humidifier output with demand. The result is accurate, responsive control.



Your DRI-STEEM representative is: